

**FIANCO DESTRO
RIGHT SIDE VIEW**

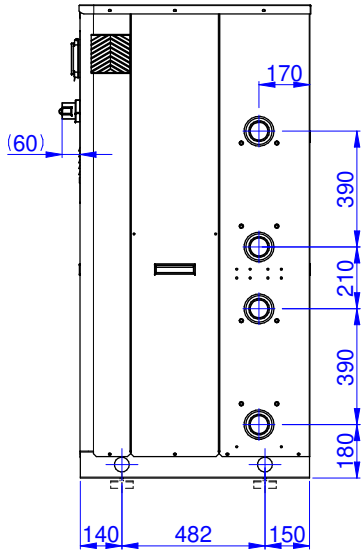

**VISTA FRONTALE
FRONT VIEW**

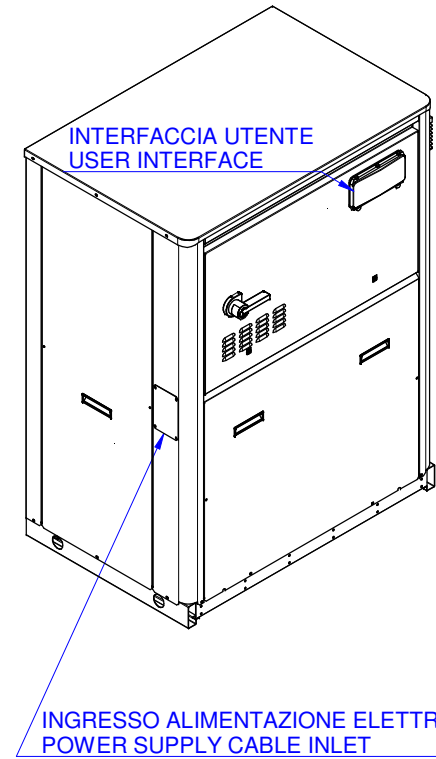
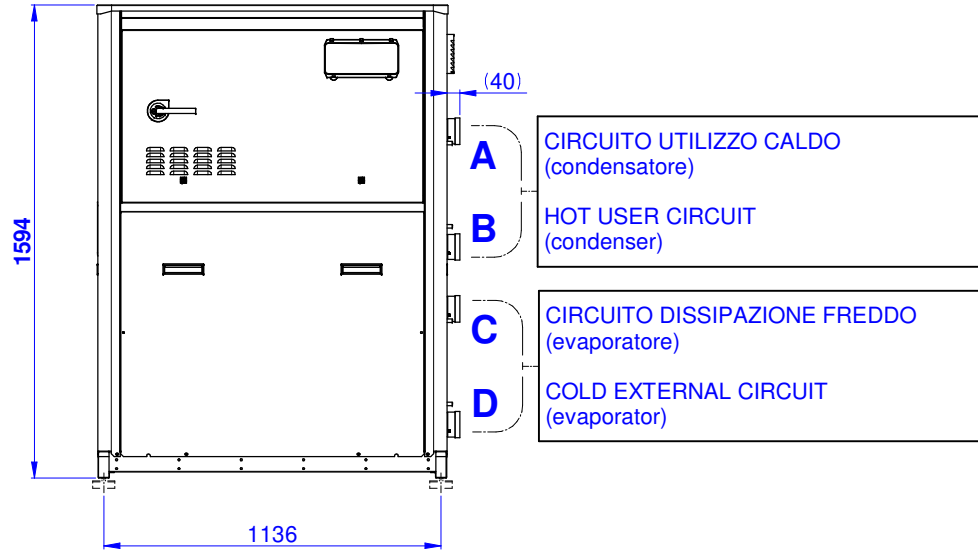

1:18

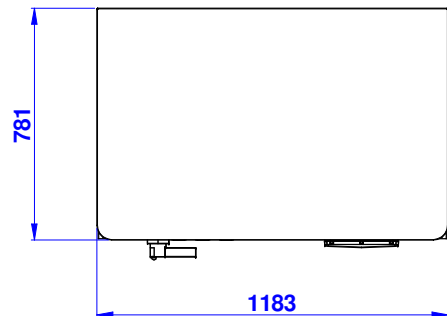

**VISTA DALL'ALTO
TOP VIEW**

	VERSIONE SOLO CALDO ONLY HEATING VERSION	
CIRCUITO UTILIZZO CALDO HOT USER CIRCUIT	A=	Uscita acqua Water outlet
	B=	Ingresso acqua Water inlet
CIRCUITO DISSIPAZIONE FREDDO COLD EXTERNAL CIRCUIT	C=	Ingresso acqua Water inlet
	D=	Uscita acqua Water outlet
CONNESSIONI IDRAULICHE HYDRAULIC CONNECTIONS	3" VICTAULIC	

	Data/e-Visto/Ckd	Rev.	Descrizione modifiche - Modifications description	
	Data/e-Visto/Ckd	Rev.	Descrizione modifiche - Modifications description	
Data/e-Visto/Ckd	Rev.	Descrizione modifiche - Modifications description		
Data - Date 25/10/2017	Autore tavola - 2D drawing designer Grossi		Autore modello - 3D model designer Grossi	
Descrizione - Description Dimens. EKW F1 W - Swep		Serie - Series EKW	Materiale - Material	
		Modello - Model F1	QUOTE SENZA INDICAZIONE DI TOLLERANZA GRADO DI PRECISIONE MEDIO - UNI 5307-63	
Codice/Disegno - Code/Drawing HF640J2272S		Peso - Weight (kg)	Rev.	Visto - Checked