



eneren

your future-proof choice

www.eneren.it
info@eneren.it



REV

Deumidificatori verticali con recuperatore ad altissima efficienza



RER

Deumidificatori orizzontali con recuperatore ad altissima

ALLEGATO DISEGNI

SOMMARIO

1	DISEGNI DIMENSIONALI	4
1.1	RER 015.....	4
1.2	RER 020.....	5
1.3	RER 035.....	7
1.4	RER 050.....	9
1.5	RER 100.....	11
1.6	REV 020	14
1.7	REV 035	16
1.8	REV 050 E REV 070	18

1 DISEGNI DIMENSIONALI

1.1 RER 015

1.1.1 Dimensionale RER 015 (tutte le versioni)

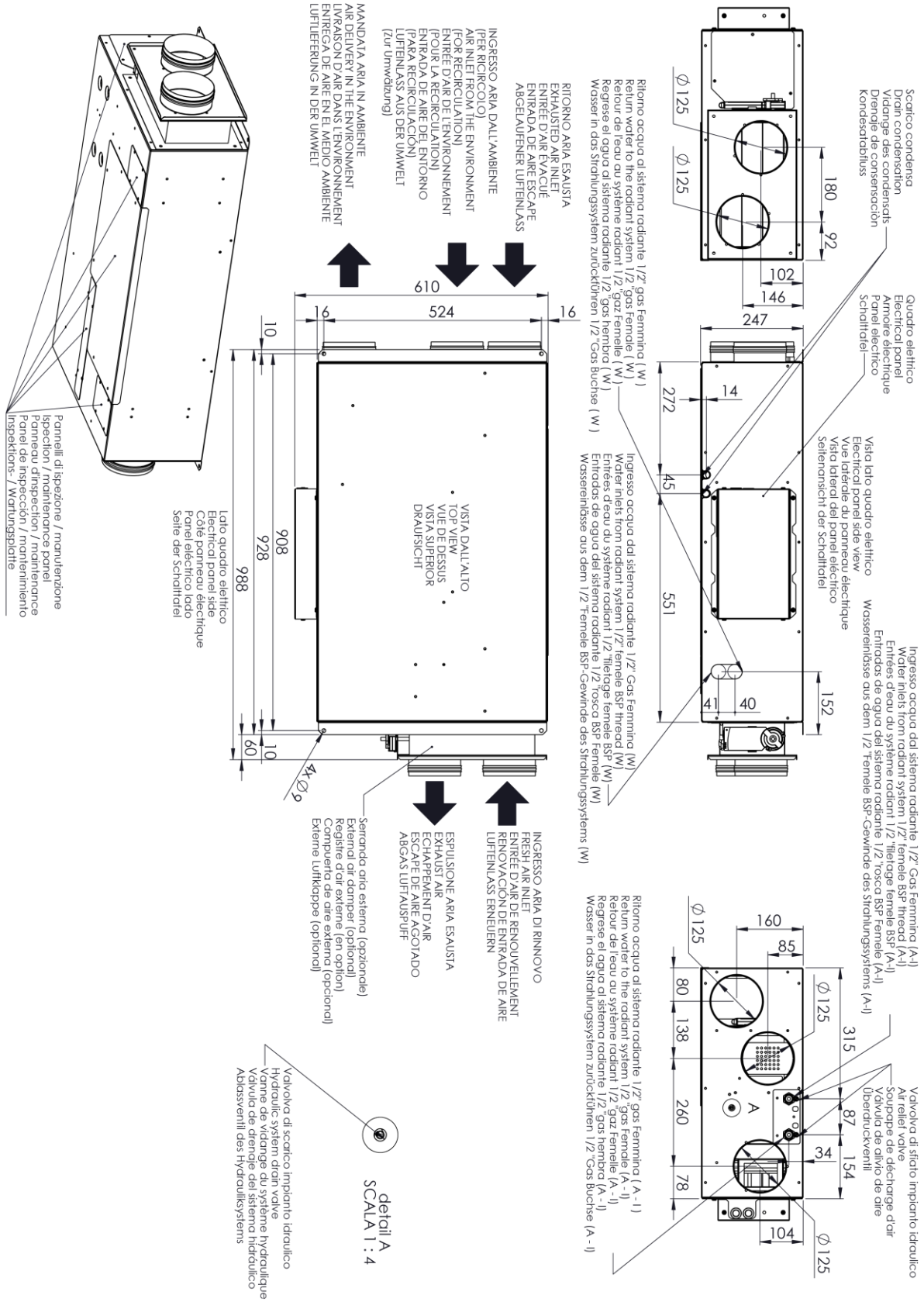

1.2.2 Plenum di mandata RER 020

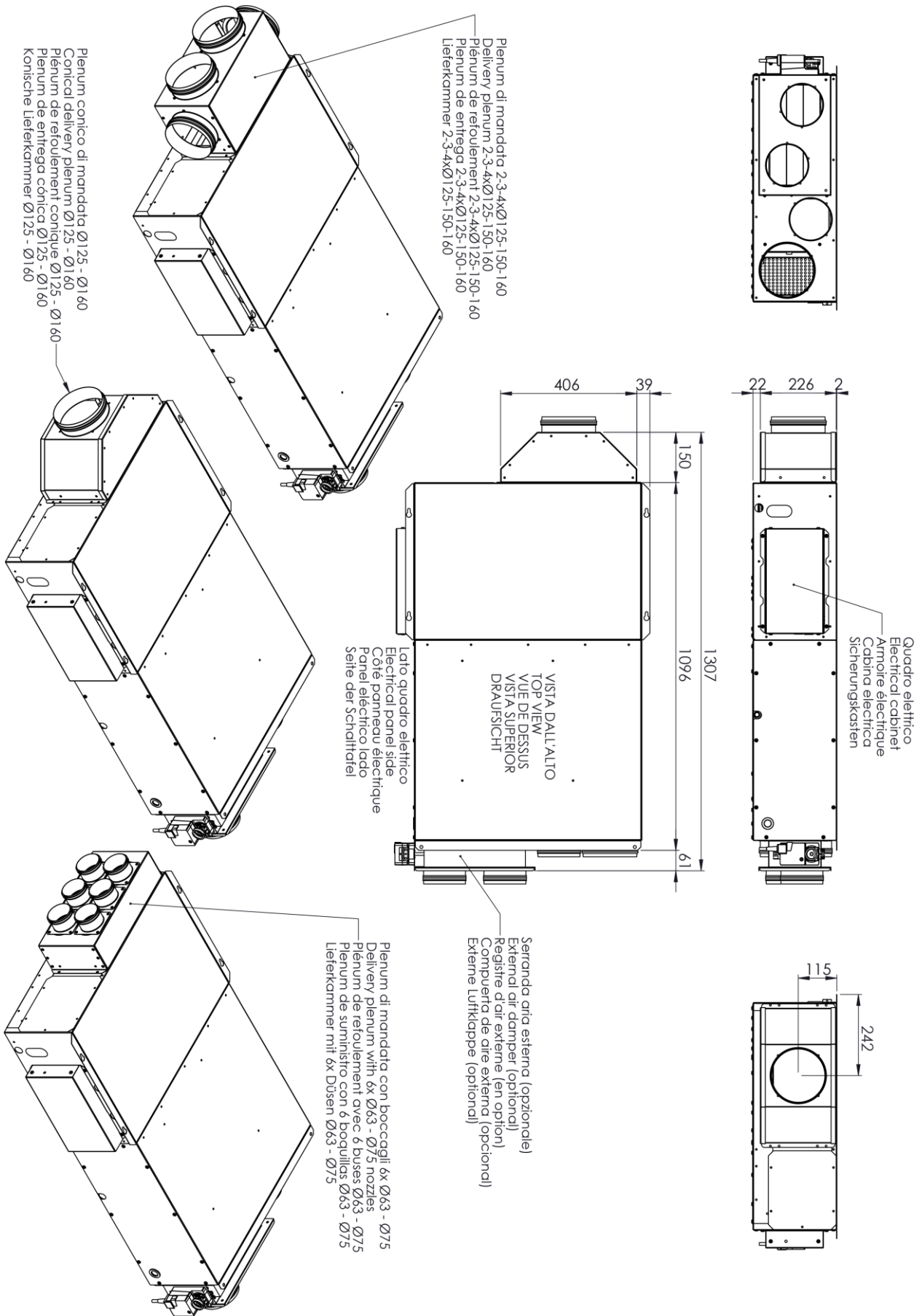

1.3.2 Plenum di mandata e di ricircolo RER 035

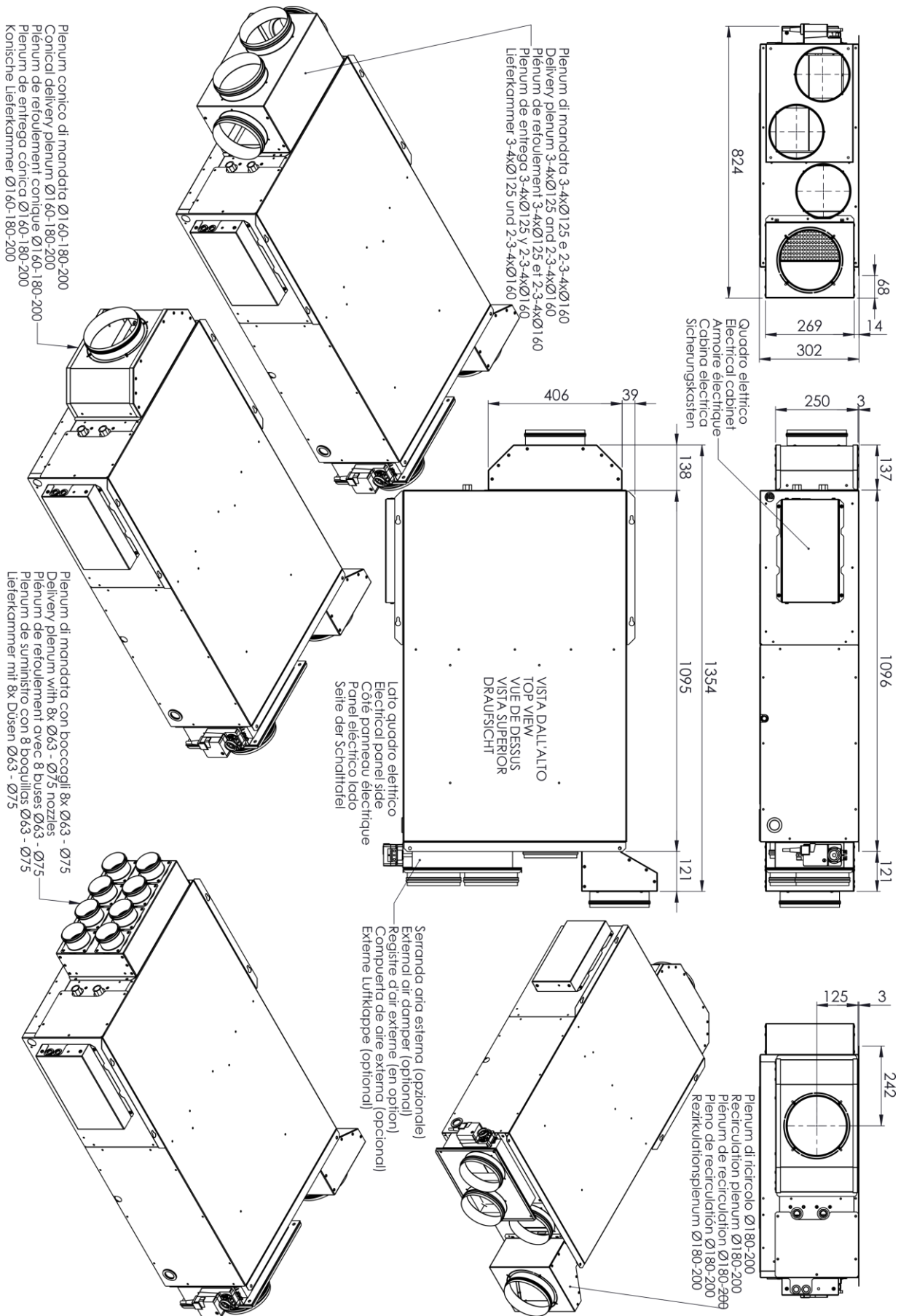

1.4.2 Plenum di mandata e di ricircolo RER 050

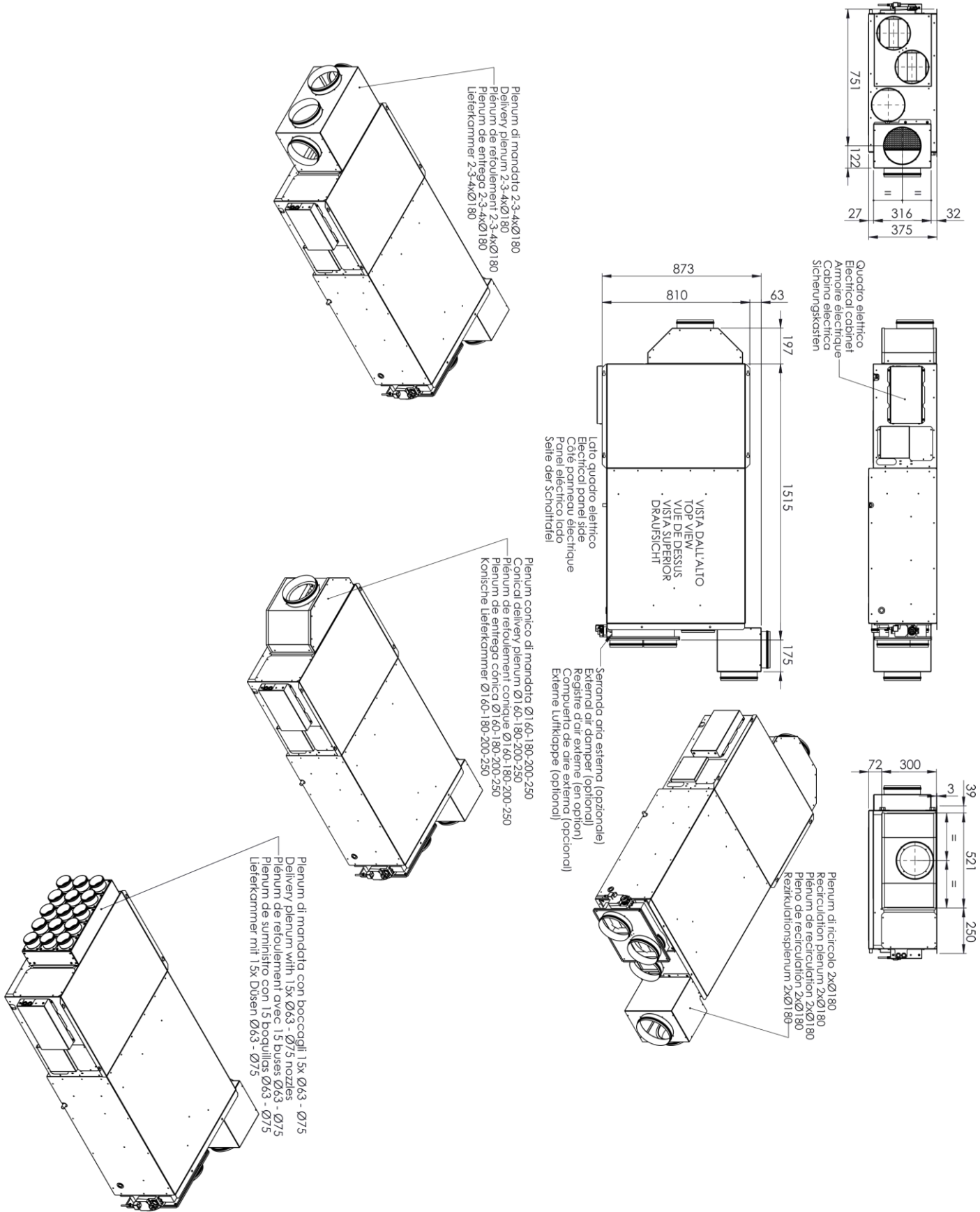

1.5 RER 100

1.5.1 Dimensionale RER 100 (tutte le versioni)

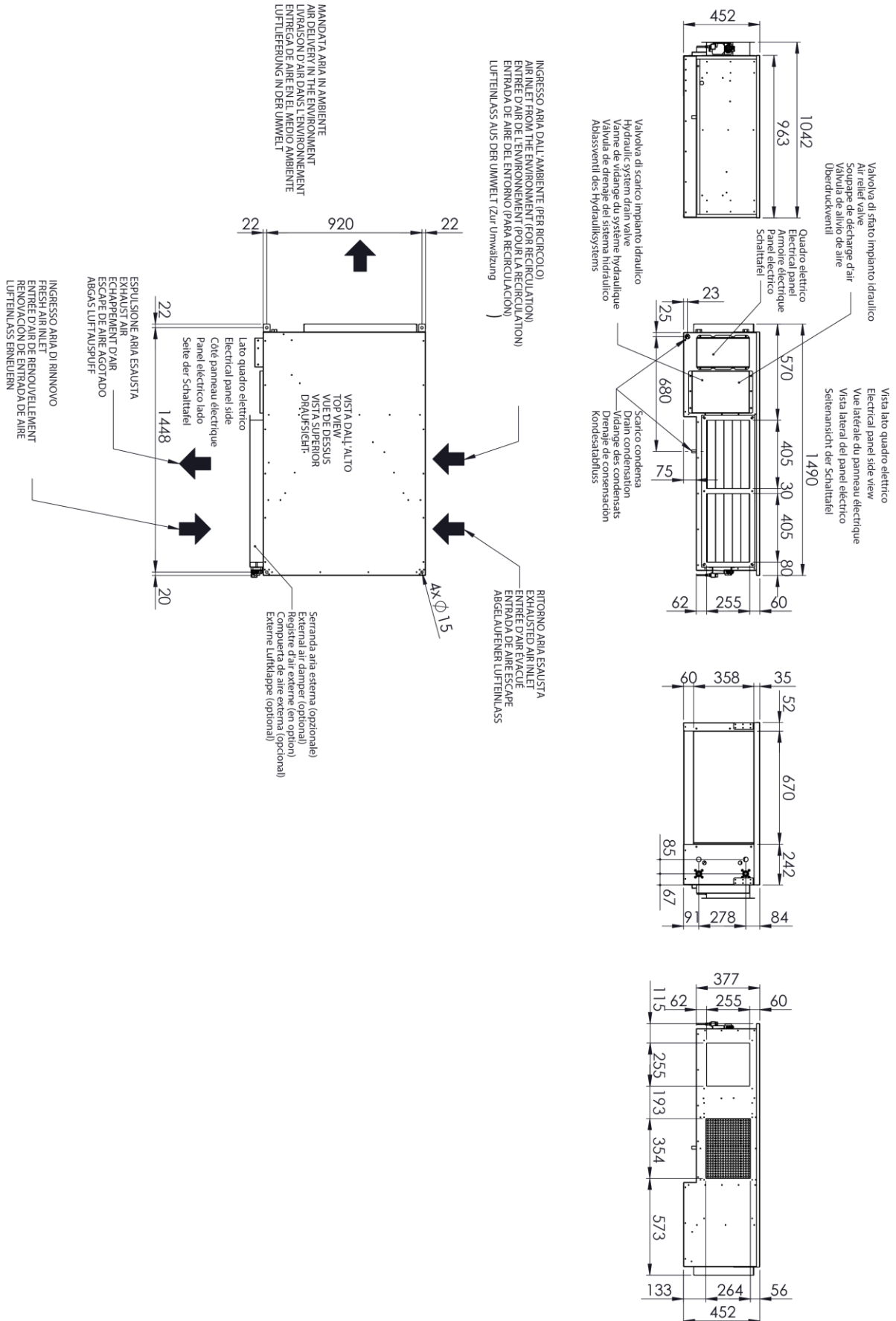

Pannelli di ispezione / manutenzione
Inspection / maintenance panel
Panneau d'inspection / maintenance
Panel de inspection / mantenimiento
Inspektors- / Wartungsplatte

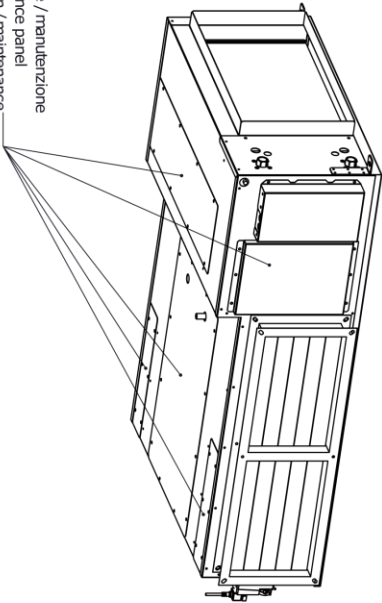

Ritorno acqua al sistema radiante 1/2" Gas Femmina (I)
Water outlets to radiant system 1/2" Female BSP thread (I)
Sortes d'eau vers le système rayonnant 1/2" filetage femelle BSP (I)
Salidas de agua al sistema radiante Rosca hembra BSP de 1/2" (I)
Wasserablassse zum 1/2" BSP-femengewinde (I) des Strahlungssystems

Ingresso acqua del sistema radiante 1/2" Gas Femmina (I)
Water inlets from radiant system 1/2" Female BSP thread (I)
Entrées d'eau du système radiant 1/2" filetage femelle BSP (I)
Entradas de agua del sistema radiante 1/2" rosca BSP Femelle (I)
Wasserinlassse aus dem 1/2" Femelle BSP-Gewinde des Strahlungssystems (I)

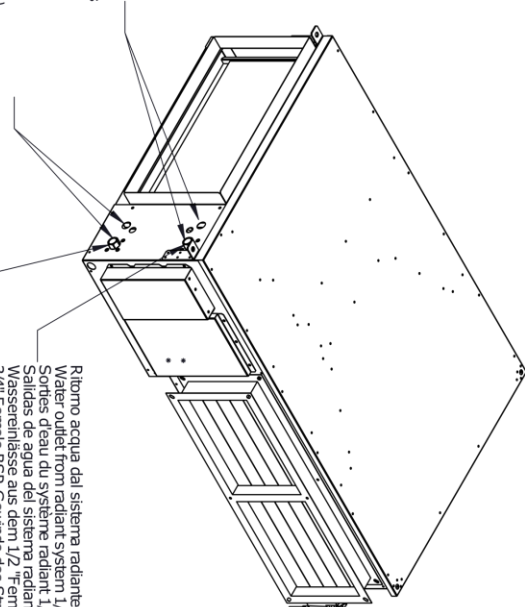

Ritorno acqua dal sistema radiante 1/2" Gas Femmina (A) - 3/4" Gas Femmina (W)
Water outlet from radiant system 1/2" Female BSP thread (A) - 3/4" Female BSP thread (W)
Sortes d'eau du système radiant 1/2" filetage femelle BSP (A) - 3/4" filetage femelle BSP (W)
Salidas de agua del sistema radiante 1/2" rosca BSP Femelle (A) - 3/4" rosca BSP Femelle (W)
Wasserinlassse aus dem 1/2" Femelle BSP-Gewinde des Strahlungssystems (A) - 3/4" Femelle BSP-Gewinde des Strahlungssystems (W)

Ingresso acqua dal sistema radiante 1/2" Gas Femmina (A) - 3/4" Gas Femmina (W)
Water inlets from radiant system 1/2" Female BSP thread (A) - 3/4" Female BSP thread (W)
Entrées d'eau du système radiant 1/2" filetage femelle BSP (A) - 3/4" filetage femelle BSP (W)
Entradas de agua del sistema radiante 1/2" rosca BSP Femelle (A) - 3/4" rosca BSP Femelle (W)
Wasserinlassse aus dem 1/2" Femelle BSP-Gewinde des Strahlungssystems (A) - 3/4" Femelle BSP-Gewinde des Strahlungssystems (W)

1.5.2 Plenum di mandata e di ricircolo RER 100

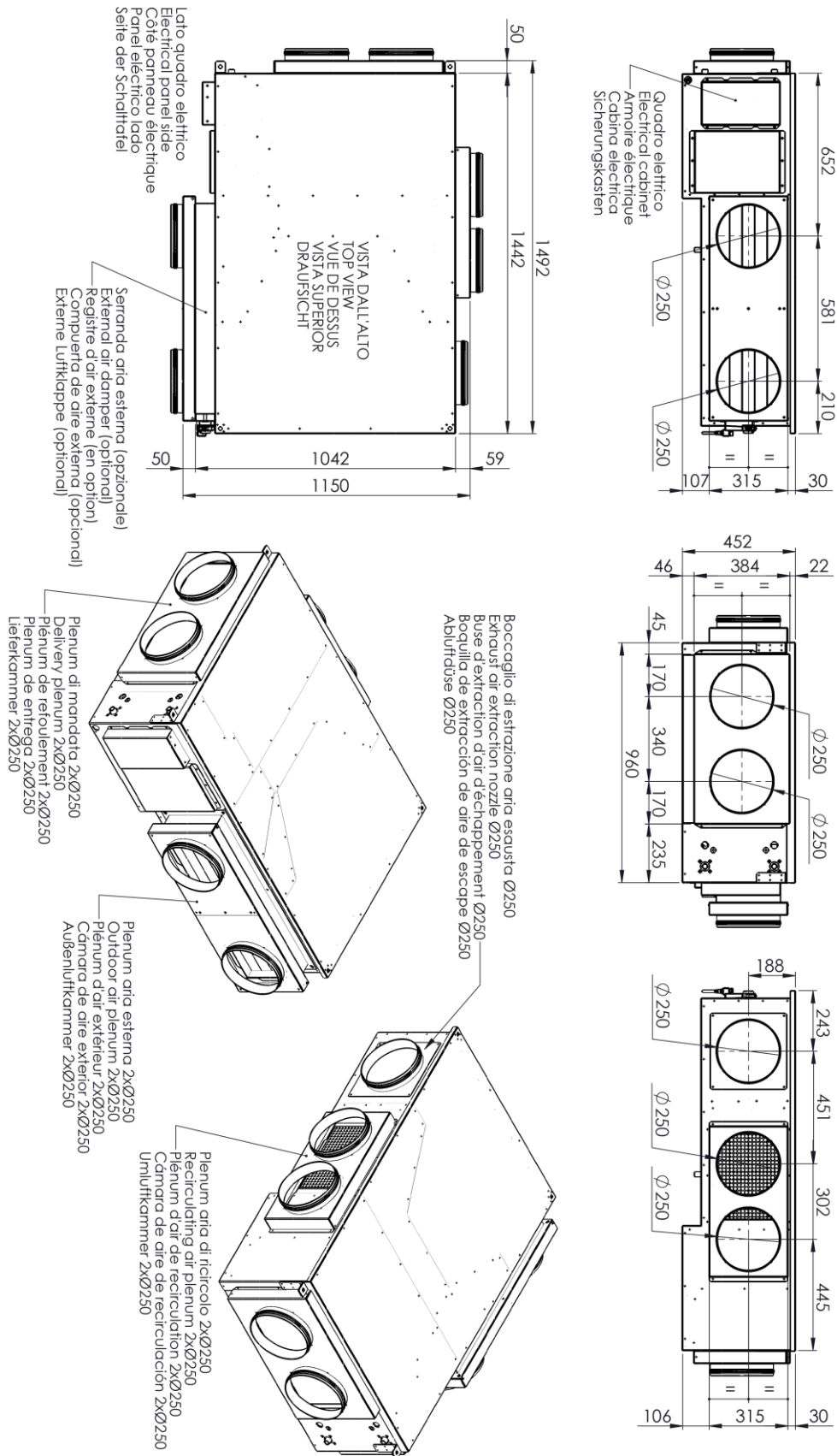

1.6 REV 020

1.6.1 Dimensionale REV 020 (tutte le versioni)

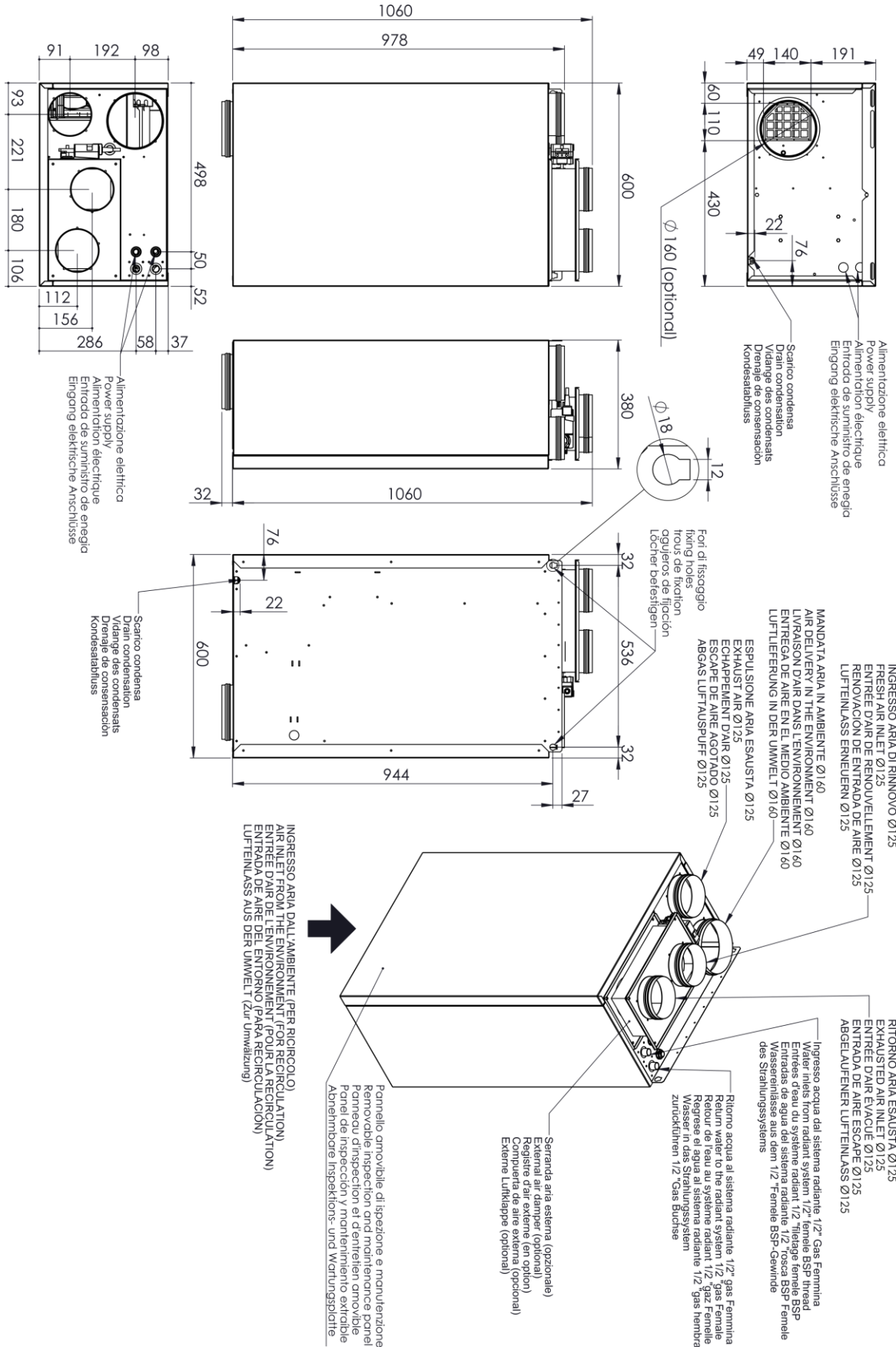

1.6.2 Dimensionale plenum ricircolo REV 020

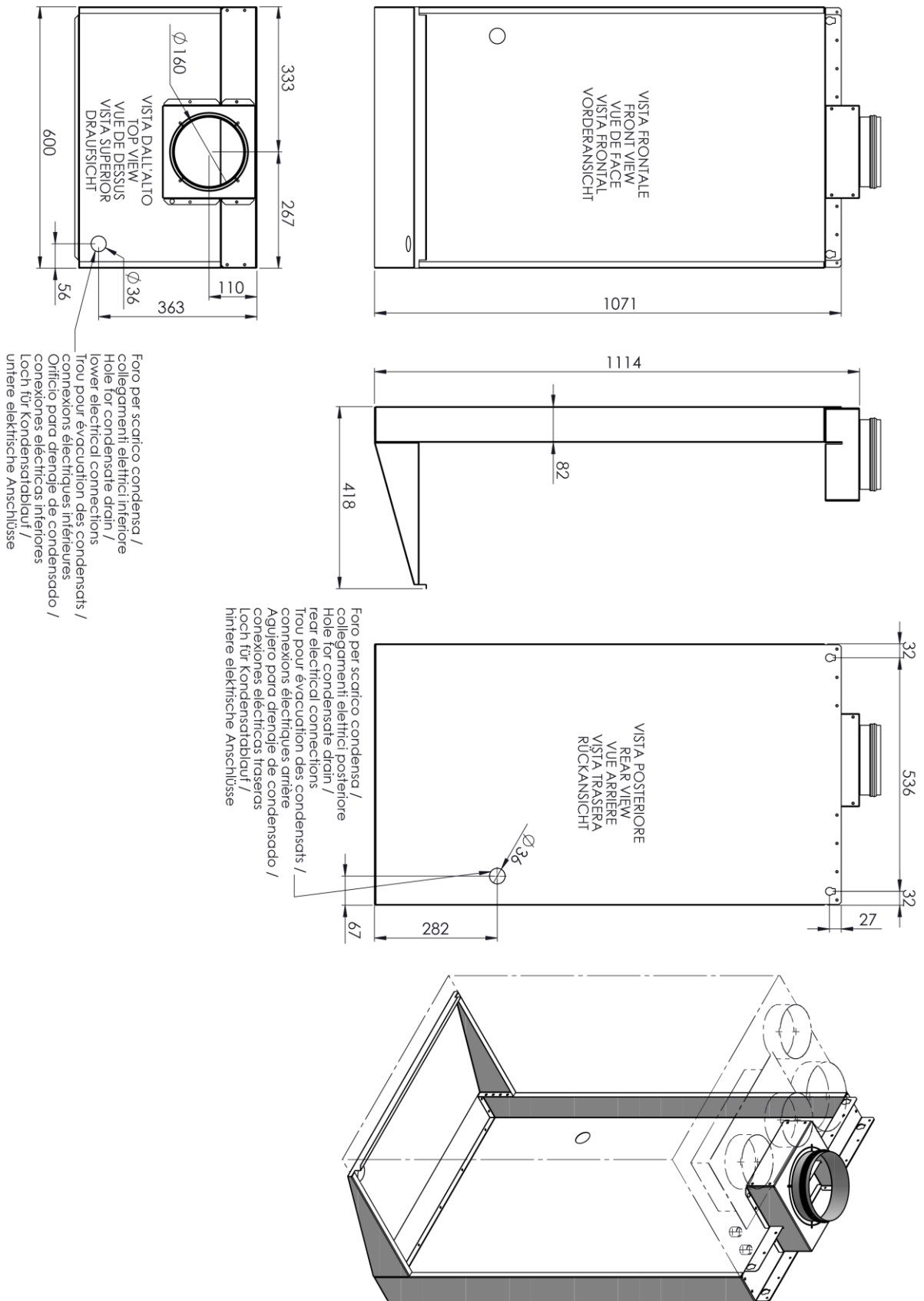

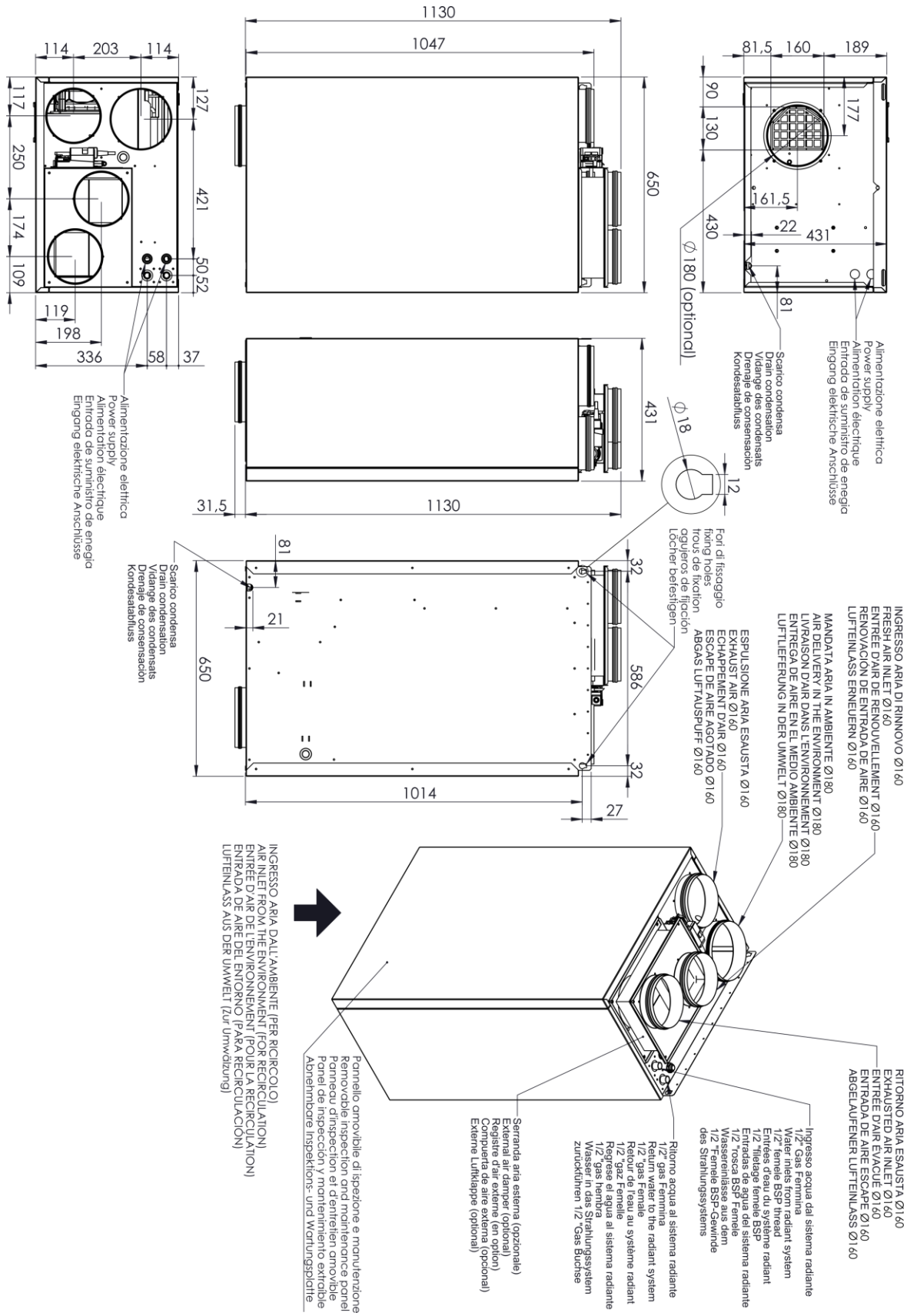
1.7 REV 035
1.7.1 Dimensionale REV 035 (tutte le versioni)

1.7.2 Dimensionale plenum ricircolo REV 035

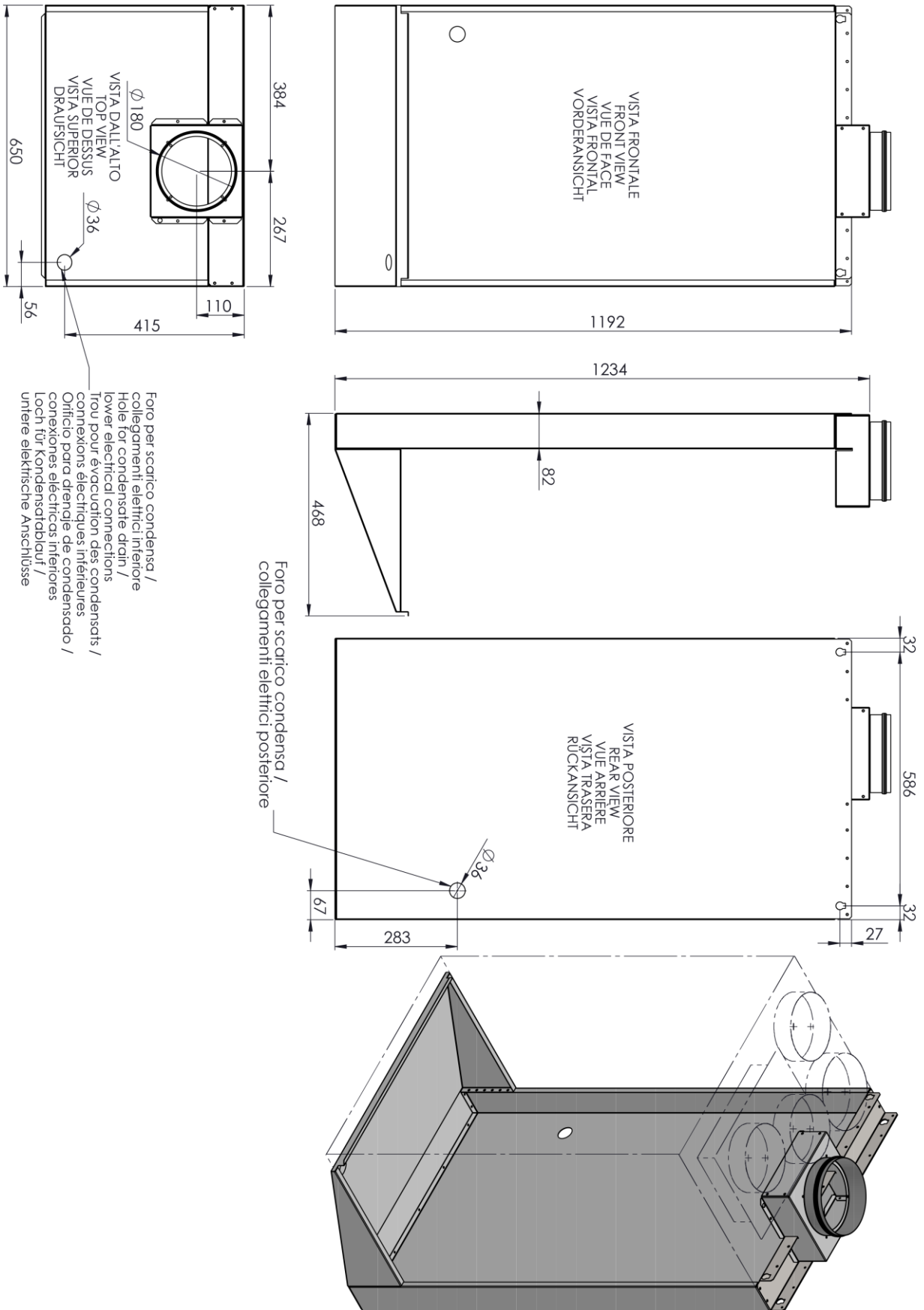

1.8 REV 050 e REV 070

1.8.1 Dimensionale REV 050 e REV 070 (tutte le versioni)

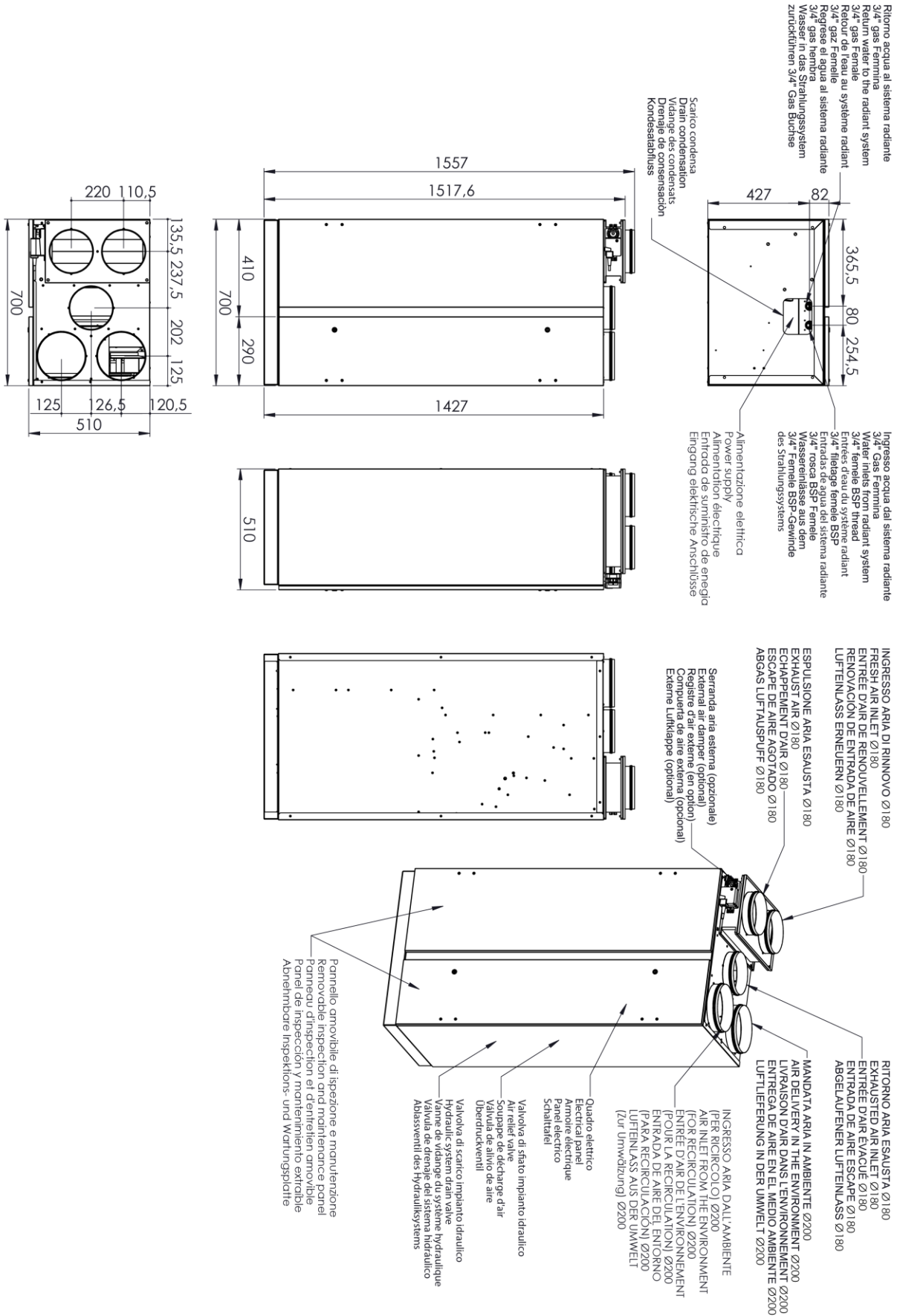



Eneren S.r.l.
info@eneren.it - www.eneren.it

Sede operativa: Viale Spagna, 31/33 - 35020 - Tribano (PD) - Italy

Sede legale: Viale Spagna, 31/33 - 35020 - Tribano (PD) – Italy

Tel +39 049 9588511 - Fax +39 049 9588522

Registro AEE: IT18080000010592