

VISTA DAL BASSO  
BOTTOM VIEW  
VUE CI-DESSOUS  
VISTA DESDE ABAJO  
BLICK VON UNTEN

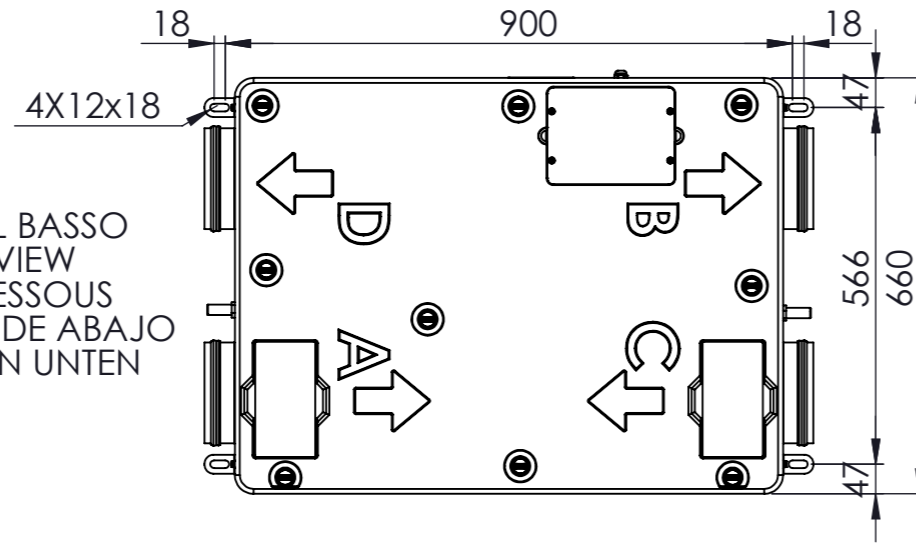

Quadro elettrico  
Electrical panel  
Armoire électrique  
Panel electrico  
Schalttafel

Accesso filtri aria  
Air filters acces  
Accès aux filtres à air  
Acceso a filtros de aire  
Zugang zu Luftfiltern

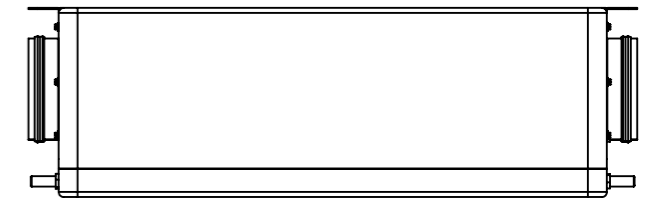
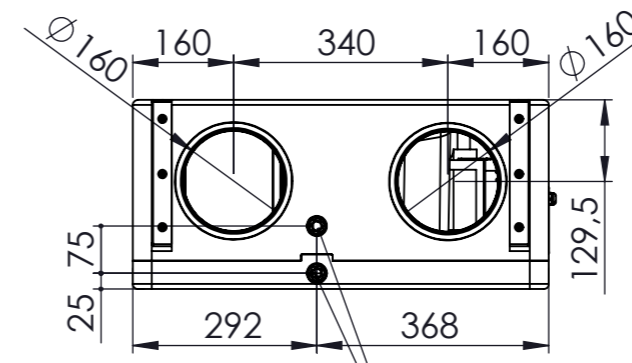
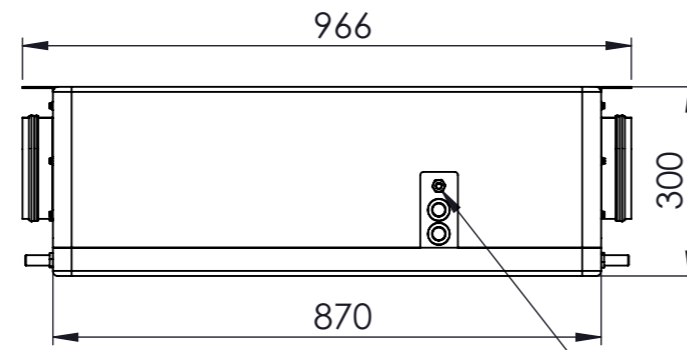
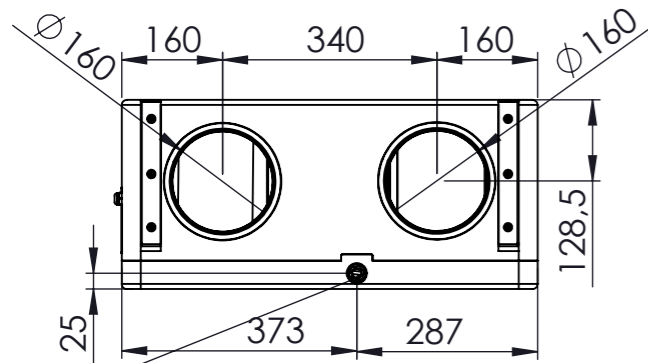
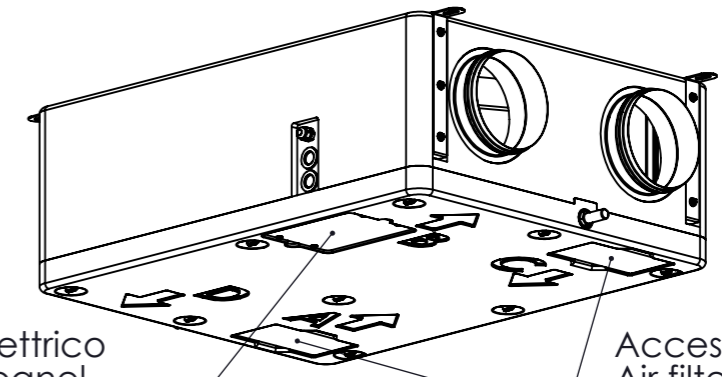

Scarico condensa (macchina orizzontale)  
Drain condensation (horizontal machine)  
Vidange des condensats (machine horizontale)  
Drenaje de condensación (máquina horizontal)  
Kondesatabfluss (horizontale Maschine)

Alimentazione elettrica  
Power supply  
Alimentation électrique  
Entrada de suministro de enegia  
Eingang elektrische Anschlüsse

Scarico condensa (macchina verticale)  
Drain condensation (vertical machine)  
Vidange des condensats (machine verticale)  
Drenaje de condensación (máquina vertical)  
Kondesatabfluss (vertikale Maschine)

INGRESSO ARIA DI RINNOVO / RITORNO ARIA ESAUSTA  
FRESH AIR INLET / RETURN OF EXHAUSTED AIR  
ENTRÉE D'AIR DE RENOUVELLEMENT / RETOUR D'AIR ÉVACUÉ  
ENTRADA DE AIRE FRESCO / DEVOLUCIÓN DEL AIRE ESCAPADO  
LUFTEINLASS ERNEUERN / RÜCKKEHR DER ABGASLUFT

ESPULSIONE ARIA ESAUSTA / MANDATA ARIA DI RINNOVO  
EXHAUST AIR / RENEWED AIR DELIVERY  
ECHAPPEMENT D'AIR / SORTIE DE L'AIR RENOUVELÉ  
ESCAPE DE AIRE AGOTADO / ENTREGA DE AIRE RENOVADO  
ABGAS LUFTAUSPUFF / VERLÄNGERUNG DER LUFTLIEFERUNG

VISTA DALL'ALTO  
TOP VIEW  
VUE DE DESSUS  
VISTA SUPERIOR  
DRAUFSICHT

RITORNO ARIA ESAUSTA / INGRESSO ARIA DI RINNOVO  
RETURN OF EXHAUSTED AIR / FRESH AIR INLET  
RETOUR D'AIR ÉVACUÉ / ENTRÉE D'AIR DE RENOUVELLEMENT  
DEVOLUCIÓN DEL AIRE ESCAPADO / ENTRADA DE AIRE FRESCO  
RÜCKKEHR DER ABGASLUFT / LUFTEINLASS ERNEUERN

MANDATA ARIA DI RINNOVO / ESPULSIONE ARIA ESAUSTA  
RENEWED AIR DELIVERY / EXHAUST AIR  
SORTIE DE L'AIR RENOUVELÉ / ECHAPPEMENT D'AIR  
ENTREGA DE AIRE RENOVADO / ESCAPE DE AIRE AGOTADO  
VERLÄNGERUNG DER LUFTLIEFERUNG / ABGAS LUFTAUSPUFF

	Data/e - Visto/Ckd	Rev.	Descrizione modifiche - Modification description	
	Data/e - Visto/Ckd	Rev.	Descrizione modifiche - Modification description	
	Data/e - Visto/Ckd 24/06/20	Rev. A	Descrizione modifiche - Modification description Aggiunto modello 035	
	Data - Date 20/04/2020	Autore tavola - 2D drawing designer M. Peraro		Autore modello - 3D model designer M. Peraro
Descrizione - Description Disegno dimensionale - Dimensional draw - dessin dimensionnel - dibujo dimensional - Maßzeichnung RDE 020 - RDE 035		Serie - Series RDE	Materiale - Material -	
Codice/Disegno - Code/Drawing -		Peso - Weight (kg) -	Rev. A	Visto - Checked 
		Modello - Model 020 - 035	QUOTE SENZA INDICAZIONE DI TOLLERANZA GRADO DI PRECISIONE MEDIO - UNI 5307-63	

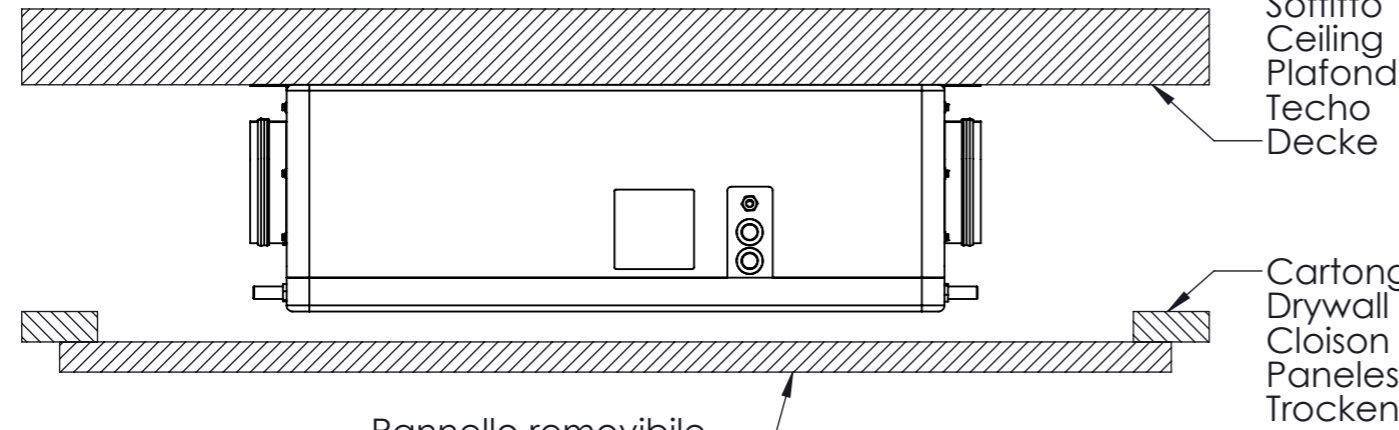

Pannello removibile  
Removable panel  
Panneau amovible  
Panel extraíble  
Abnehmbare Verkleidung

Le quote indicate sono da considerarsi le minime utili per il corretto posizionamento dell'unità e per le successive manutenzioni.  
The measures indicated are to be considered the minimum useful for the correct positioning of the unit and for subsequent maintenance.  
Les mesures indiquées doivent être considérées comme le minimum utile pour le positionnement correct de l'unité et pour l'entretien ultérieur.  
Las medidas indicadas deben considerarse las mínimas útiles para el posicionamiento correcto de la unidad y para su posterior mantenimiento.  
Die angegebenen Maßnahmen sind als Mindestnutzen anzusehen die korrekte Positionierung des Geräts und für die spätere Wartung.

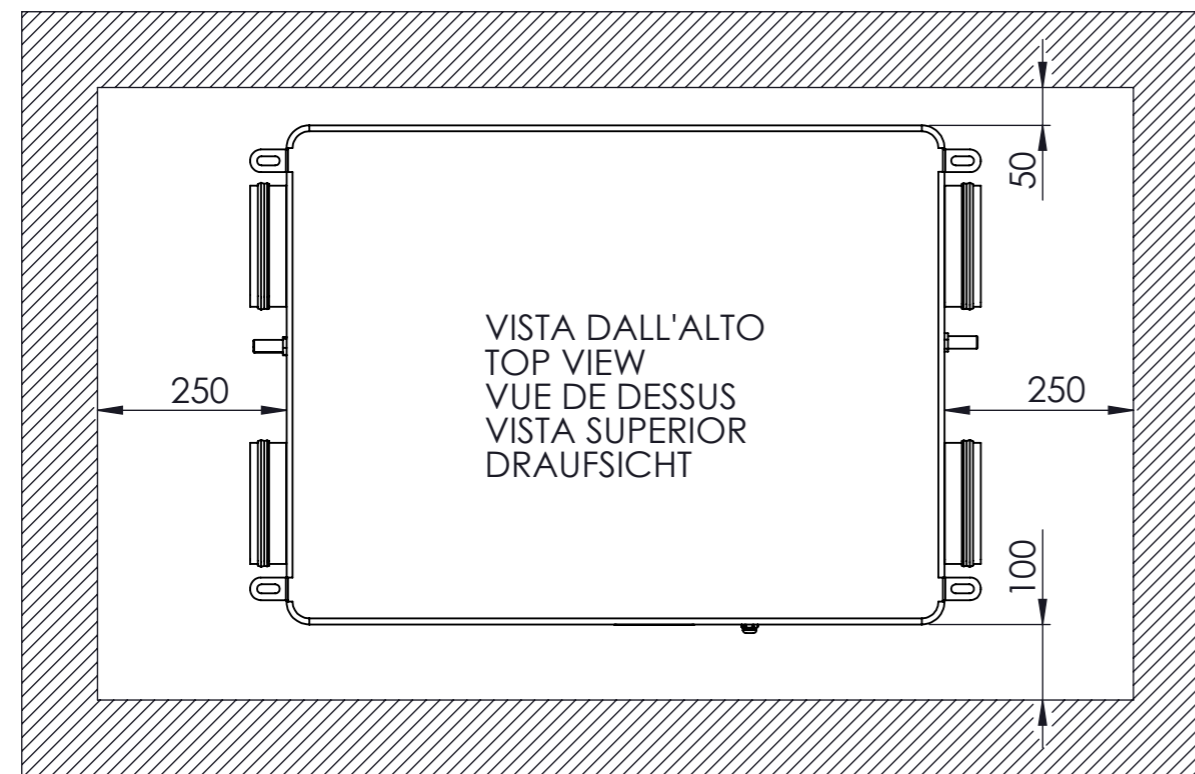

Lato accesso alimentazione elettrica  
Power supply access side  
Côté d'accès à l'alimentation  
Lado de acceso a la fuente de alimentación  
Zugangsseite der Stromversorgung

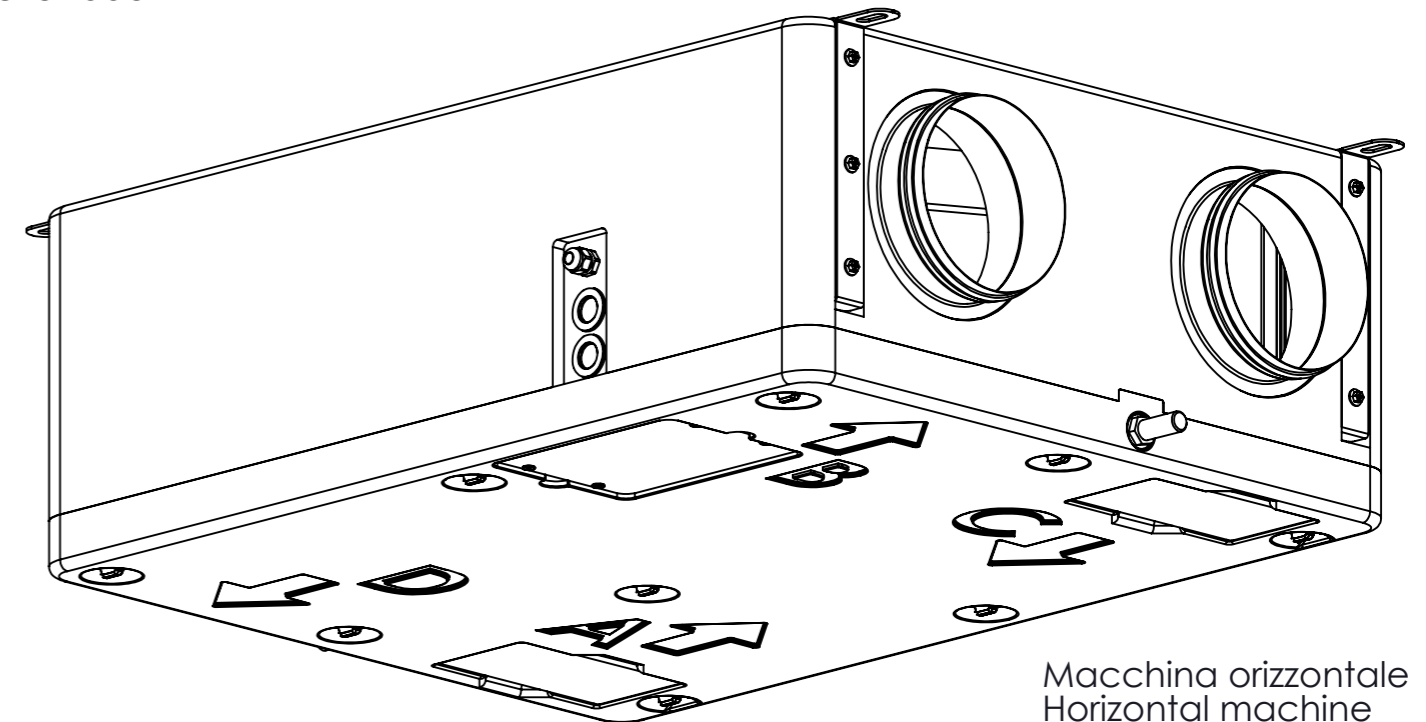

Macchina orizzontale  
Horizontal machine  
Machine horizontale  
Máquina horizontal  
Horizontale Maschine

	Data/e - Visto/Ckd	Rev.	Descrizione modifiche - Modification description	
	Data/e - Visto/Ckd	Rev.	Descrizione modifiche - Modification description	
	Data/e - Visto/Ckd 24/06/20	Rev. A	Descrizione modifiche - Modification description Aggiunto modello 035	
	Data - Date 25/11/2019	Autore tavola - 2D drawing designer M. Peraro		Autore modello - 3D model designer M. Peraro
Descrizione - Description Spazi di rispetto - Respect spaces - Respectez les espaces - Espacios de respeto - Räume respektieren RDE 020 - 035			Serie - Series RDE	Materiale - Material -
Codice/Disegno - Code/Drawing -			Modello - Model 020 - 035	QUOTE SENZA INDICAZIONE DI TOLLERANZA GRADO DI PRECISIONE MEDIO - UNI 5307-63
			Peso - Weight (kg) -	Rev. A
			Visto - Checked 	

Le quote indicate sono da considerarsi le minime utili per il corretto posizionamento dell'unità e per le successive manutenzioni.  
 The measures indicated are to be considered the minimum useful for the correct positioning of the unit and for subsequent maintenance.  
 Les mesures indiquées doivent être considérées comme le minimum utile pour le positionnement correct de l'unité et pour l'entretien ultérieur.  
 Las medidas indicadas deben considerarse las mínimas útiles para el posicionamiento correcto de la unidad y para su posterior mantenimiento.  
 Die angegebenen Maßnahmen sind als Mindestnutzen anzusehen die korrekte Positionierung des Geräts und für die spätere Wartung.

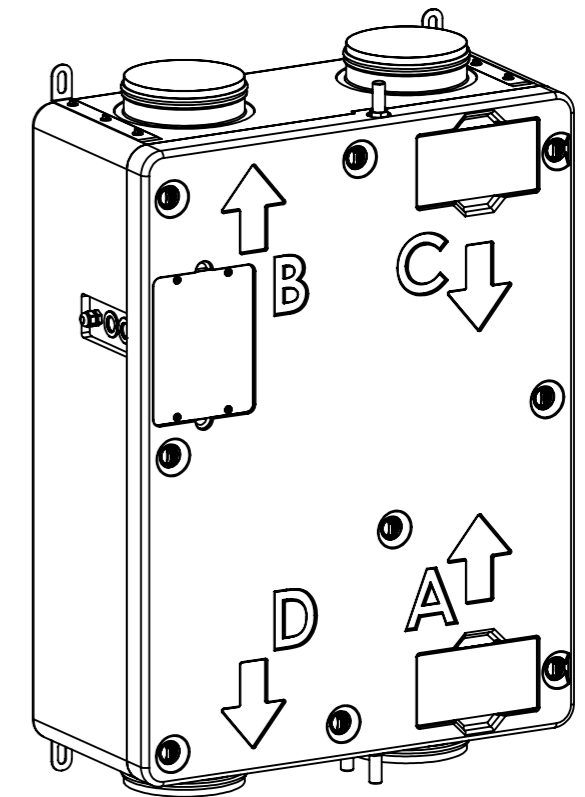
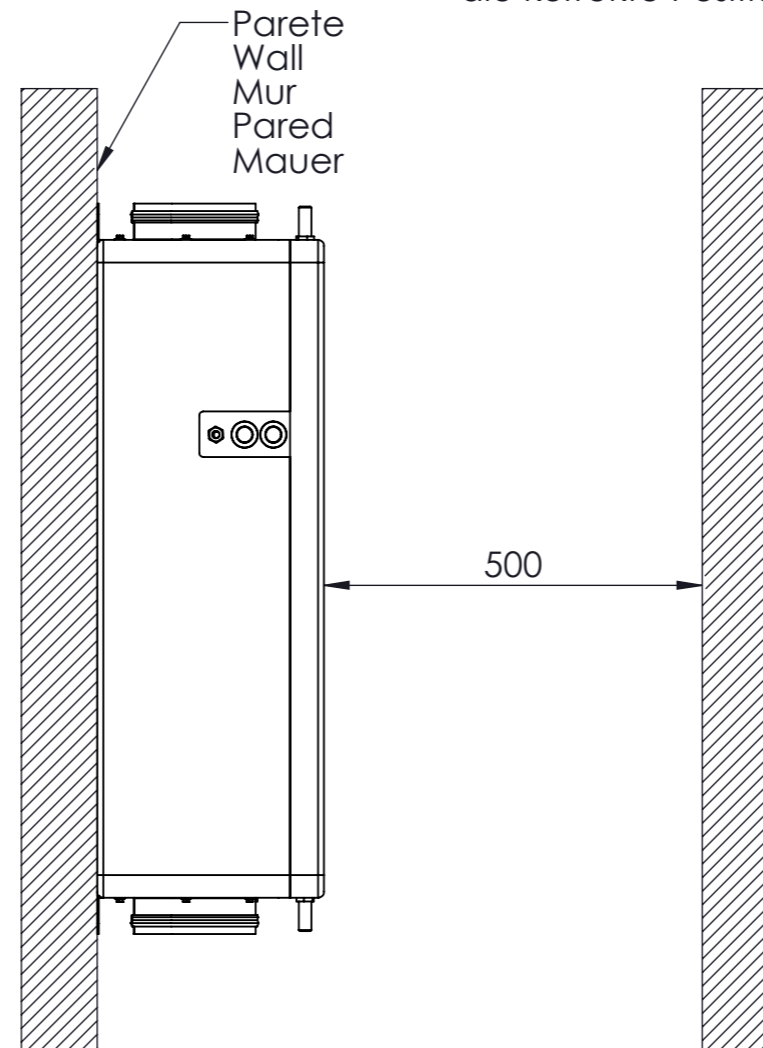
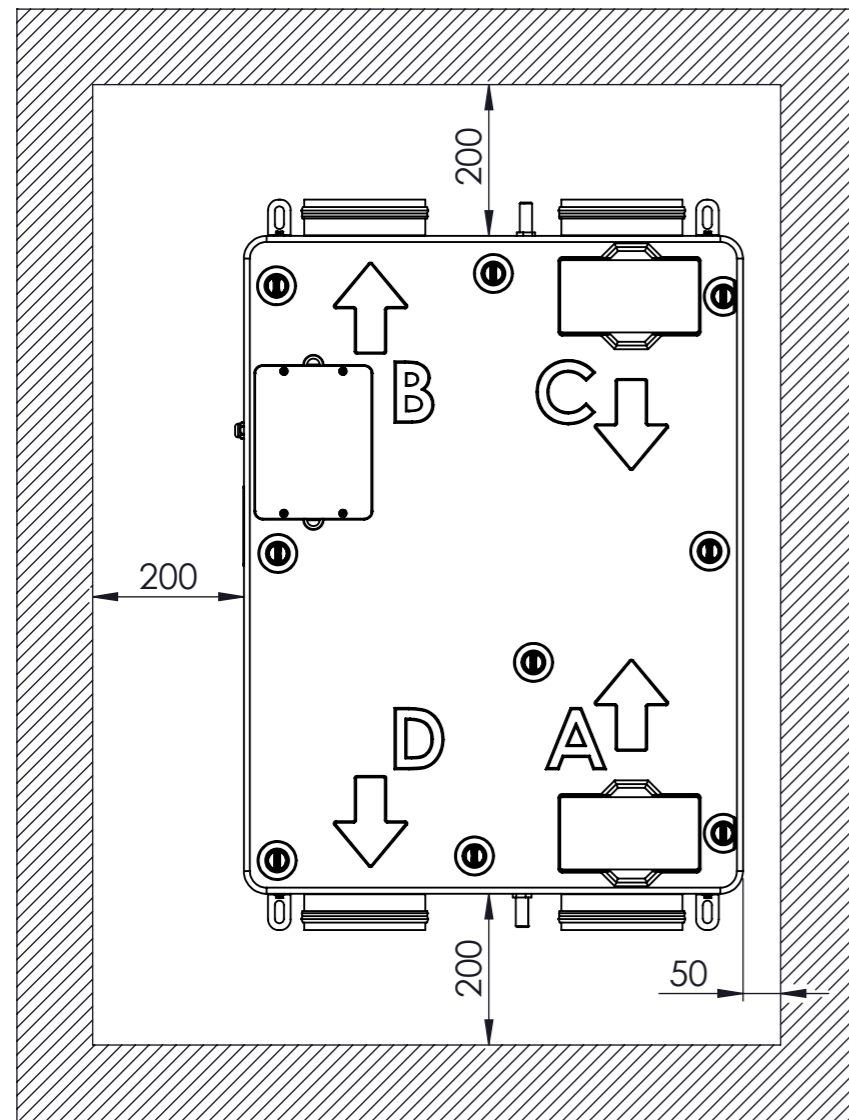

Macchina verticale  
 Vertical machine  
 Machine verticale  
 Máquina vertical  
 Vertikale Maschine

	Data/e - Visto/Ckd	Rev.	Descrizione modifiche - Modification description	
	Data/e - Visto/Ckd	Rev.	Descrizione modifiche - Modification description	
	Data/e - Visto/Ckd 24/06/20	Rev. A	Descrizione modifiche - Modification description Aggiunto modello 035	
	Data - Date 20/04/2020	Autore tavola - 2D drawing designer M. Peraro		Autore modello - 3D model designer M. Peraro
Descrizione - Description Spazi di rispetto - Respect spaces - Respectez les espaces - Espacios de respeto - Räume respektieren RDE 020 - 035		Serie - Series RDE	Materiale - Material -	
		Modello -Model 020 - 035	QUOTE SENZA INDICAZIONE DI TOLLERANZA GRADO DI PRECISIONE MEDIO - UNI 5307-63	
Codice/Disegno - Code/Drawing -		Peso - Weight (kg) -	Rev. -	Visto - Checked David G.