

Predisposizione entrata tubi posteriore
Rear pipe inlet predisposition

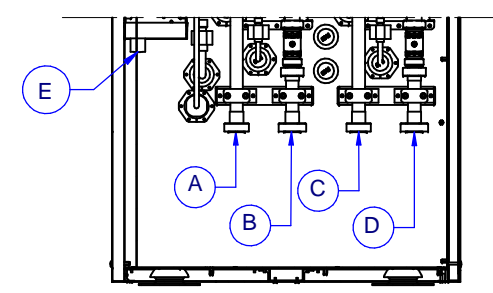
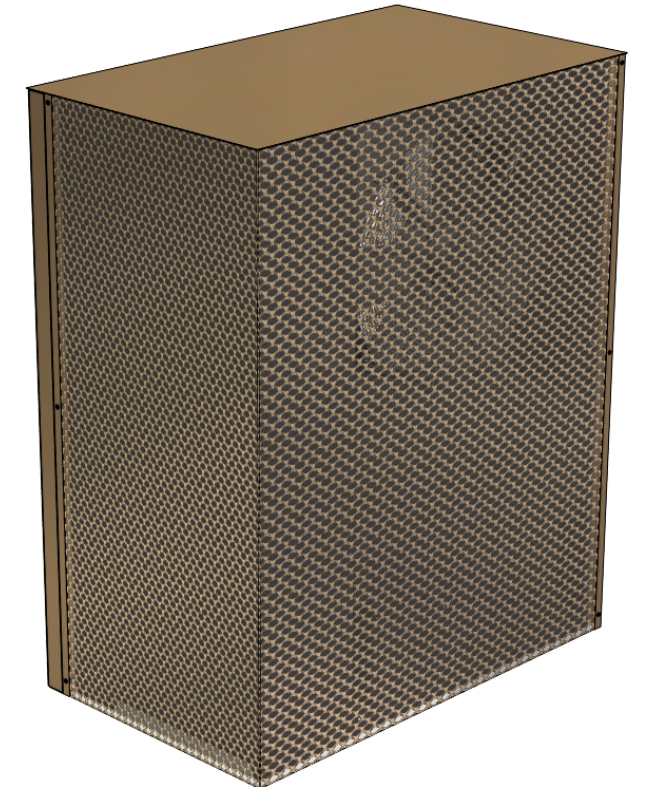
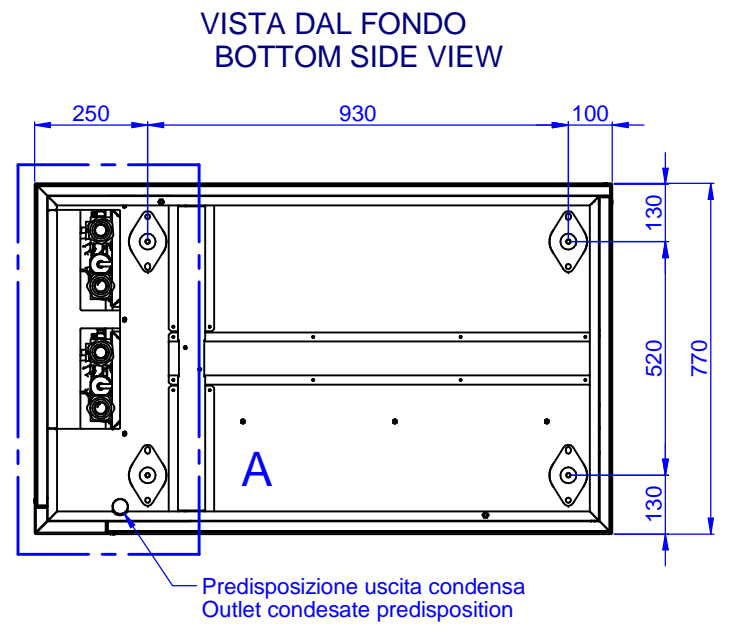
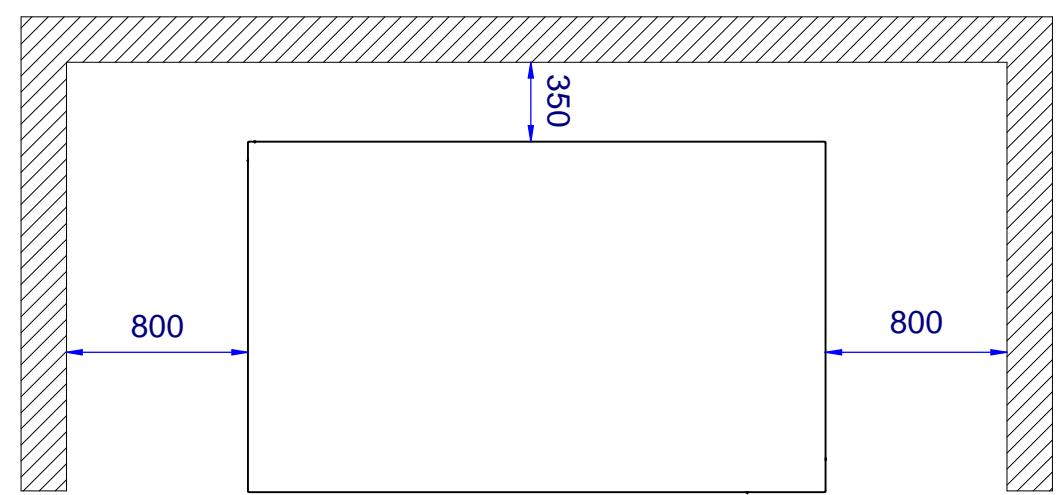

SEZIONE B-B

CONNESSIONI IDRAULICHE - HYDRAULIC CONNECTIONS			
RIF	ATTACCHI-CONNECTIONS	TIPO - TYPE	VERSIONE - VERSION
A	OUT Utenza - User water outlet	G 1 1/2" F	M - H - H_3way valve
B	IN Utenza - User water intlet	G 1 1/2" F	M - H
B	OUT ACS - Domestic hot water outlet	G 1 1/2" F	H_3 way valve
C	OUT ACS - Domestic hot water outlet	G 1 1/2" F	M
C	IN Utenza - User water intlet	G 1 1/2" F	H_3 way valve
D	IN ACS - Domestic hot water inlet	G 1 1/2" F	M - H_3way valve
E	Scarico condensa - Water drain	Ø32 mm	M - H

Data/e-Visto/Ckd	Rev.	Descrizione modifiche - Modifications description
Data/e-Visto/Ckd	Rev.	Descrizione modifiche - Modifications description
Data/e-Visto/Ckd	Rev.	Descrizione modifiche - Modifications description
Data - Date	Autore tavola - 2D drawing designer	Autore modello - 3D model designer
09/02/2022	Grillo M.	marco.grillo
Descrizione - Description	Serie - Series	Materiale - Material
Dimensioni e ingombro Overall dimensions	HVE H-M	-
Codice/Disegno - Code/Drawing	Modello - Model	QUOTE SENZA INDICAZIONE DI TOLLERANZA GRADO DI PRECISIONE MEDIO - UNI 5307-63
HF640J3471	006/017	
Peso - Weight (kg)	Rev.	Visto - Checked
-	-	