



USER MANUAL

ENW

WATER-COOLED HEAT PUMPS OR CHILLERS
AIR CONDITIONING
INDUSTRIAL APPLICATIONS AND PROCESS CONTROL



EN
TRANSLATION OF THE ORIGINAL INSTRUCTIONS

HF61GJ0632C / 04_23

INTRODUCTION

ENW

 **WARNING**

CAREFULLY READ THIS MANUAL BEFORE USING THE UNIT.

 **DECLARATION OF CONFORMITY**

The declaration of conformity is attached separately to the documents on board the unit, usually placed inside the electrical compartment.

Dear Customer,

Thanking you for choosing our products, we are pleased to provide you this manual for the correct use of equipment.

Please read the recommendations described in the following pages carefully and keep the manual available to personnel who will be responsible for managing and maintaining the unit.

Our company is at your complete disposal for any and all questions that you should require both in the unit starting phase and at any time of its utilization.

Should scheduled and unscheduled maintenance be necessary, please contact our After-sales Technical Service for assistance and spare parts.

Please find here attached our direct contacts in case you may need assistance:



ENEREN S.r.l.
Viale Spagna, 31/33
35020 Tribano (Pd) ITALY
Tel + 39 049 9271513
Fax + 39 049 9588522
e-mail : info@eneren.it



049-9271513



support@eneren.it

START-UP INSTRUCTIONS

1 YOUR INSTALLATION

All the tips required for a perfect installation of the equipment can be found in the installation manual.
It is important to place a net filter at all water circuit inlets.

The filter must be made of stainless steel with a mesh that does not exceed 1 mm.

2 REQUIRED ACCESSORIES FOR A PROPER INSTALLATION OF THE UNIT

For the proper operation of the unit and for the validity of the warranty, the installation of the following hydraulic components will be necessary:

- Y-strainers in the inlet pipes to the unit;
- anti-vibration couplings in each pipe connected to the unit;
- appropriately dimensioned safety valves on each circuit of the system;
- appropriately dimensioned expansion vessels on each circuit of the system.

3 FIRST START-UP

With at least 15 working days in advance, send the machine start request via email or fax to the following contact ENEREN:

Fax. 049 9588522

e-mail: support@eneren.it

Tel. 049 9271513

ENEREN Assistance will organize the intervention by putting you in contact with Authorized Technical Assistance Center of the area.

All the preliminary checks and testing of the machine will be carried out together with your staff.

Your staff will be given instructions for the correct running of the machine.

4 WARRANTY ISSUE

For the warranty to be valid, the first start-up by an Authorized Technical Assistance Center is mandatory.
After testing, the Authorized Technical Assistance Center will issue a valid test certificate for the machine warranty.

Each unit has an identification plate that is located on its frame and inside the electrical control panel, which shows all the data necessary for the installation, maintenance and traceability of the machine.

THE LABEL SHOWS THE FOLLOWING DATA:



- Manufacturer/Marketing body
- CE mark, possibly accompanied by a subscript that identifies the certifying body for the Pressure Equipment Directive 2014/68/EU (PED). The number of the certifying body must be indicated for units of a PED category equal to or greater than class 2.
- Series and size of the unit
- Date of manufacture
- Main technical data

Note the model, the serial number, the final refrigerant charge and the machine reference diagrams attached to this manual so that they can be easily found in case of data plate damaging and system maintenance.

 **ATTENTION**

Never remove the label. This shows the serial number of the unit from which it is possible to obtain information about the technical features and the components installed, to then identify the unit correctly.

Modello - Model	
Matricola - Serial number	
Codice identificativo - ID code	
Data di produzione - Date of production	
Categoria PED/ 2014/68/EU - Category PED/ 2014/68/EU	
Procedura di valutazione conformità PED - PED conformity module	
Max pressione ammissibile (PS) lato alta pressione - Max allowable pressure (PS) high pressure side [bar-r]	
Max pressione esercizio (PS) lato bassa pressione - Max allowable pressure (PS) low pressure side [bar-r]	
Max/min temperatura di stoccaggio - Max/min storage temperature [°C]	
Max/min temperatura ambiente di funzionamento - Max/min ambient working temperature [°C]	
Potenza frigorifera* - Cooling capacity* [kW]	
EER*	
Potenza termica* - Heating capacity* [kW]	
COP*	
Refrigerante - Refrigerant [Ashrae 15/1992] / GWP	
Carica refrigerante - Refrigerant charge [kg]	C1 C2 C3 C4
Refrigerante aggiunto - Added refrigerant [kg]	C1 C2 C3 C4
Carica totale refrigerante - Total charge refrigerant [kg]	
CO2 equivalenti - CO2 equivalent [t]	
Taratura pressione lato alta - High pressure switch set [bar-r]	
Taratura pressione lato bassa - Low pressure switch set [bar-r]	
Taratura valvola sicurezza refrigerante lato alta/bassa pressione - Safety valve refrigerant high/low pressure side set [bar-r]	
Massima pressione esercizio circuito acqua - Max working pressure water circuit [bar-r]	
Taratura valvola sicurezza acqua - Safety valve water side set [bar-r]	
Alimentazione elettrica - Power supply	
Potenza massima assorbita - Max absorbed power [kW]	
Corrente massima - Full load ampere FLA [A]	
Corrente di spunto - Starting current LRA [A]	
Schema elettrico - Wiring diagram	
Schema frigorifero - Refrigeration diagram	
Peso a vuoto - Empty weight [kg]	
* EN14511-2	
Contiene gas fluorurati ad effetto serra disciplinati dal protocollo di Kyoto/ Contains fluorinated greenhouse gases governed by the Kyoto protocol Ermeticamente sigillato/Hermetically sealed	

SAFETY SYMBOLS	
 WARNING	With reference to additions or recommendations for the correct use of the unit.
 DANGER	With reference to dangerous situations that may occur with the use of the unit to guarantee personal safety.
 ATTENTION	With reference to dangerous situations that may occur with the use of the unit to prevent damage to property and to the unit itself.

GENERAL CAUTIONARY NOTES

The operating rules contained in this manual are an integral part of the unit supply and are valid exclusively for the units covered by this manual. They contain all the useful and necessary information for safe operation and ideal, recommended use of the unit. The declaration of conformity is attached individually to the literature kept on the machine, usually inside the control cabinet.

Please follow the instructions given below:

- Read carefully the instruction manual which should be considered an integral part of the unit. Every operator and the personnel in charge of unit maintenance must read the manual throughout carefully and observe its prescriptions.
- The employer is requested to make sure that the operator has the necessary aptitude requirements for operating the unit and has carefully read the manual.
- The instruction manual must be easily available to the operation and maintenance personnel. Keep the manual for the entire working life of the unit. Make sure any updates that are received are integrated into the text.
- Hand over the manual to any other user or subsequent owner.
- Use the manual so that the contents are not damaged - entirely or in part. Do not remove, tear off or rewrite parts of the manual for any reason.
- Keep the manual with care; it must be available at the unit, stored in a special container, to protect it from moisture and heat, until final scrapping of the machine. The location where the manual is kept must be known to the user of the unit, to the managers, to the persons in charge of transportation, installation, use, maintenance, repairs, and end-of-life dismantling and scrapping. If the manual is lost or partially damaged, so that it is no longer possible to read all of its contents, it is advisable to request a new one from the manufacturer.
- Avoid hasty and incomplete preparation that lead to improvisation and cause many accidents.

Pay close attention to the safety symbols shown in the table on the previous page and to their meaning.

Before starting to work, read through and strictly observe the following suggestions:

- the operator must always have the instruction manual readily available at any time;
- plan each action carefully;
- before beginning to work, make sure that the safety devices work properly and you have no doubts about their operation; otherwise, do not under any circumstances start the unit;
- carefully observe the warnings relating to special hazards contained in this manual;
- constant and accurate preventive maintenance always guarantees high operational safety of the unit. Never postpone necessary repairs and have them carried out exclusively by skilled personnel, by only using original spare parts.

THE MANUFACTURER shall not be liable for any accident to persons or property which may occur due to:

- failure to comply with the instructions in this manual regarding the operation, use and maintenance of the unit;
- violent actions or incorrect operations during the maintenance of the unit;
- changes made to the unit without a prior written authorisation obtained from the MANUFACTURER;
- events that are, in any case, unrelated to the normal and correct use of the unit;
- in any case, should the user attribute an incident that may have occurred to a unit fault, he or she must prove that the resulting damage occurred has a main and direct consequence of such "fault".

This manual reflects the state of the art at the time of unit sale: The MANUFACTURER reserves the right to update its products and manuals without any obligation to update earlier products and manuals, except in special circumstances. These may not be considered inadequate only because they have been subsequently updated based on new experience.

ATTENTION

- The installer must provide adequate documentation that must comply with EN 378-3 if applicable in the country of

installation; otherwise, reference should be made to the local regulations in force.

- When installing or when working on the chiller unit, it is necessary to strictly comply with the regulations contained in this manual, observe the instructions provided on-board the unit and in any case, adopt all the necessary precautions.
- The presence of pressurised fluids in the refrigerant circuit and of electrical components can create hazardous situations during installation and maintenance.
- Any action on the unit must be carried out by qualified and authorised personnel. In the event of a fault, do not attempt repairs on your own and do not let unauthorised technicians carry out repairs, or the guarantee will no longer be valid.
- The initial start-up must be carried out exclusively by qualified personnel authorised by the marketing entity (see annex).
- Before performing any work on the unit, be sure to have disconnected power supply.
- For maintenance service or repairs always and exclusively use original spare parts. THE MANUFACTURER declines all responsibility for damages that may occur due to non-compliance with the above.
- The unit is guaranteed according to the contractual agreements entered into upon its sale: however, failure to comply with the rules and instructions contained in this manual and any modification in the unit not previously authorised, will cause an immediate loss of guarantee validity.
- This manual describes the intended use of the unit and provides instructions for its handling, installation, assembly, adjustment and use. It supplies information on the maintenance schedule, how to order spare parts, the presence of residual risks, and staff training. Therefore, before handling, installing, using or carrying out any maintenance on the unit, read the manual very carefully.
- Please note that the use and maintenance manual is not intended to be a substitute for adequate user experience. For particularly complex maintenance operations, this manual serves as a reminder of the main tasks to carry out for operators having received specific training, for example, in the form of training courses delivered by the manufacturer.
- Please ensure that all users have fully understood the directions for use and the meaning of any symbols provided on the unit.
- Possible accidents can be avoided by following these technical instructions drafted in accordance with the Machinery Directive 2006/42/EC and subsequent additions.
- In any case, always comply with national safety regulations.
- Do not remove or damage guards, decals, stickers and wording, especially any that are required by law. Adhesive plates are applied to the unit to make it safer to use, therefore, it is very important to replace them if they are no longer legible.

WARNING

- The electrical wiring, hydraulic and refrigeration diagrams and the technical data shown in this manual are supplied for guidance only and may be changed without prior notice for the purpose of improving the product range. For detailed information on specific models, refer to the specific documentation attached to the each product.

Any updates or additions to this use and maintenance manual are to be considered an integral part of the manual and may be requested via the contact phone numbers listed in this manual. Contact the MANUFACTURER for additional information and to share any feedback and recommendations aimed at improving the manual.

If the unit is transferred to a new owner, the MANUFACTURER expects you to please notify the address where to send any manual additions for the new user.

TABLE OF CONTENTS

1	INTRODUCTION	p. 3	10	ROUTINE MAINTENANCE AND CHECKS ..	p. 35
2	START-UP INSTRUCTIONS	p. 4	10.1	CHECKS TO BE PERFORMED BY THE USER p. 35
3	SERIES	p. 8	10.2	CHECKS AND MAINTENANCE TO BE PERFORMED BY SPECIALISED PERSONNEL p. 35
3.1	SCOPE OF APPLICATION	p. 8	10.3	COMPONENTS DESCRIPTION p. 40
3.2	PRODUCT INFORMATION	p. 9	11	SUBSTITUTION OF R410A WITH R454B REFRIGERANT	p. 41
3.3	MODELS AND VERSIONS	p. 9	12	TROUBLESHOOTING	p. 42
3.4	MAIN TECHNICAL SPECIFICATIONS	p. 10	13	RETIRING THE UNIT	p. 44
4	SAFETY PRESCRIPTIONS	p. 11	13.1	WASTE ELECTRICAL AND ELECTRONIC EQUIPMENT MANAGEMENT p. 44
4.1	GENERAL SAFETY RULES	p. 11	13.2	ENVIRONMENT PROTECTION p. 44
4.2	GENERAL PRECAUTIONS	p. 11	13.3	PACKAGING DISPOSAL p. 45
4.3	LOCATION OF SAFETY DATA PLATES	p. 14	14	SAFETY DATA SHEET OF REFRIGERANT	p. 46
4.4	MAINTENANCE PRECAUTIONS	p. 15			
4.5	PRECAUTIONS IN CASE OF REFRIGERANT LEAKAGE	p. 15			
5	TRANSPORT, INSPECTION, HANDLING, DIMENSIONS AND POSITIONING OF THE UNIT	p. 17			
5.1	TRANSPORT	p. 17			
5.2	INSPECTION	p. 17			
5.3	CONVEYANCE	p. 18			
5.4	UNPACKING	p. 20			
5.5	SITING	p. 20			
5.6	INSTALLATION CLEARANCE REQUIREMENTS	p. 21			
6	PLUMBING AND ELECTRICAL CONNECTIONS	p. 22			
6.1	HYDRAULIC CONNECTIONS	p. 22			
6.2	ELECTRICAL CONNECTIONS	p. 23			
6.3	HYDRAULIC AND REFRIGERATION DIAGRAMS	p. 24			
7	MICROPROCESSOR CONTROL	p. 27			
8	START-UP	p. 28			
8.1	PRELIMINARY CHECKS	p. 28			
8.2	OPERATING LIMITS	p. 29			
8.3	THERMAL CARRYING FLUID	p. 30			
8.4	START-UP INSTRUCTIONS	p. 31			
8.5	START-UP	p. 31			
8.6	INSPECTIONS DURING OPERATION	p. 31			
8.7	REFRIGERANT CHARGE CHECKS	p. 32			
8.8	GROUP STOP	p. 32			
9	CONTROL AND SAFETY DEVICES	p. 33			
9.1	CONTROL DEVICES	p. 33			
9.2	SAFETY DEVICES	p. 33			

3 SERIES

The ENW series of water-condensing chillers includes a range of models capable of satisfying every need:

- ENW C water-water chillers – cooling only;
- ENW D water-water chillers – dry-cooler cooling;
- ENW H water-water chillers – heat pump;
- ENW W water-water chillers – not reversible heat pump.

3.1 Scope of application

The ENW units are designed to cool-heat water and solutions containing up to 30% glycol (percentage by weight) in civil, industrial and technological air-conditioning systems. In buildings with large surface areas, the air conditioning system can be expanded step by step as new floors or areas are sold/leased, by installing a ENW unit for every floor in a small control room. This allows you to spread your investment over time. The possibility of keeping the evaporator indoors means there is no need to add glycol to the water inside the system. In addition, you can keep all components requiring routine or special maintenance in an easily accessible room. The pluses offered by these products are summed up in the following table:

ENW C-D-H-W water-condensing units:

- Occupies an extremely small surface area;
- No need to add glycol to the water in the user circuit;
- High COP [Coefficient of Performance] of the thermodynamic cycle;
- No noise outside;
- Extremely small refrigerant charge;
- Innovative aesthetics and total safety, given that the chillers are completely enclosed;
- Option of installing an outdoor dry cooler where it is not possible to use a nonrecirculating water supply to cool the condenser;
- Heat pump version with cycle reversibility at the cooling side;
- Condensing control option on the heat pump versions possible;

ENW C-D-H-W units are to be used within the operating limits stated in this manual; failure to comply with said limits will invalidate the warranties provided in the contract of sale.

WARNING

Regarding the unit setting and its use, it is important to know that:

- the units are designed and built to operate in the temperature ranges indicated in paragraph 8.2 Operating limits p. 29: applications outside the indicated limits may be authorised by the MANUFACTURER, subject to verification and subsequent written authorisation. The air-water units are equipped with electric resistors, on request, for heating the plate heat exchanger, should the unit be exposed to cold temperatures during the winter shutdown period. This resistor is activated when the water temperature at the exchanger outlet falls below the anti-freezing probe calibration temperature;

- the storage temperature of the unit must be within the limits indicated in the paragraph 8.2 Operating limits p. 29;
- **the units are designed to operate in a closed hydraulic circuit.** In the case of open tanks, it is advisable to contact the design department which will indicate the best solution to adopt, such as uncoupling the exchanger;
- be aware that in certain environments there could be sound wave reverberation;
- the installation environment must be immediately suitable from first positioning of the unit and not just after installation completion (for example, do not install and operate the unit in premises and open work sites where completion works might damage the unit);
- the unit must only be used for housing, industrial and technological conditioning; any other use is considered not recommended.
- failure to comply with the aforementioned items and those contained in the manual will cause an immediate loss of guarantee validity; in this case, the manufacturer declines all responsibility for any damage to persons, property or the unit that may derive from it.

DANGER

- Install the unit in environments without any risks of explosion, corrosion or fire.
- Any use that does not conform to the expected conditions could result in serious consequences for the unit.
- All ordinary and extraordinary maintenance operations must be carried out with the unit switched off, by disconnecting the power supply.
- Wait approximately 30 minutes after switching off the unit before carrying out any maintenance operations to avoid burns.
- During normal operation, human traffic in the area around the machine must be prevented up to at least the required buffer spaces.

ATTENTION

- Before starting any work on the unit, each operator must be perfectly familiar with its operation and its controls, and have read and understood all the technical information contained in this manual.
- It is forbidden to use the unit in conditions or for uses other than what is indicated in this manual and the MANUFACTURER may not be held responsible for breakdowns, accidents or injuries due to failure to comply with this prohibition.
- Do not repair high pressure pipes with welds.
- It is forbidden to tamper with, alter or modify, even partially, the systems or equipment described in the instruction manual, and in particular, the guards and warning symbols required for personal safety.
- It is also forbidden to operate in manners different from those indicated or fail to perform operations necessary for safety reasons.
- Safety instructions are particularly important, as well as general information contained in this manual.

3.2 Product information

All of the ENW series units are constructed with a support base and panelling made of galvanised sheet metal painted with black polyester epoxy powders oven-polymerised at 180°C.

The unit has an exclusive design enhancing the overall assembly with a smart outward appearance. Moreover the closed unit makes the components inaccessible: this aspect together with the wide use of soundproof material inside the compartment and around the compressors (optional for low-noise version) reduces the emitted sound output to exceptionally low levels ($L_p < 66$ dB-A @1 metre for larger sizes).

The hydraulic/chiller connections are envisioned on the top side to reduce the technical space required for installation.

All the panels are removable making the unit fully accessible even though routine maintenance only needs accessing from the front.

3.3 Models and versions

The ENW series units are available in the liquid chiller version (with well/mains water source or drycooler/evaporative tower), reversible heat pump and only heat pump.

It is possible to choose from different operating noise versions (Standard, Low Noise versions), and the available chilling configurations (Efficiency packs) allow an extensive power range to be covered.

All models operates with R410A refrigerant.

The naming methods and the unit configuration options are shown below.

» Example of unit configuration

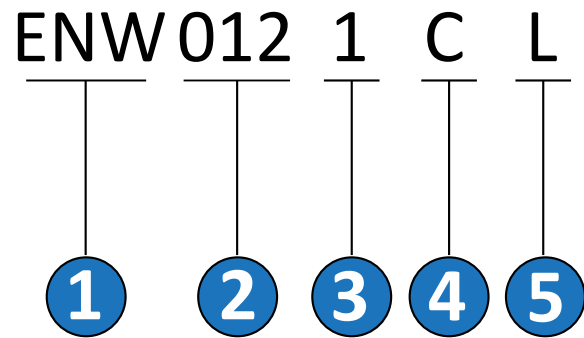

1. unit name
2. size (cooling capacity in kW/10, e.g. 012 = 120 kW)
3. efficiency packs:
 - 1 = 2 compressors/2 circuits
 - 2 = 2 compressors/1 circuit
 - 3 = 3 compressors/1 circuit
 - 4 = 4 compressors/2 circuits
4. configuration:
 - C = well or mains water cooled chiller
 - D = dry-cooler or evaporative tower water cooled chiller
 - H = reversible heat pump
 - W = not reversible heat pump
5. implementation:
 - S = standard
 - L = silenced

3.3.1 Cooling circuit

The entire cooling circuit is built in the manufacturer factory using only components of the finest quality brands and processes conforming to the specifications of Directive 2014/68/UE for brazing. The chillers are built with a single cooling circuit using only components supplied by leading international manufacturers.

Compressors: only scroll-type compressors of leading international manufacturers are used in the ENW units. The scroll compressor is presently the best solution in terms of reliability and efficiency in the range of power up to 182 kW for each circuit and in terms of noise level.

NOTE: the scroll compressor, like all hermetic compressors, is classified as a pressure vessel according to the PED insofar as its low-pressure section is concerned, to which the PS indicated on the rating plate refers.

Heat exchangers: all chillers have heat exchangers with braze-welded AISI 304 austenitic stainless steel plates and connections made of AISI 304 L, characterised by a reduced carbon content to facilitate brazing. Braze-welded plate exchangers represent the state of the art in terms of heat exchange efficiency and make it possible to significantly reduce the refrigerant charge compared to traditional solutions. The high turbulence induced by the internal corrugation of the plates combined with their perfectly smooth surface also helps prevent dirt build-up and the formation of scale on the condenser side.

NOTE: due to the presence of heat insulation, the data plate is not legible as required under 2014/68/UE PED. However, the exchanger serial number and declaration of conformity are recorded during production and constitute an integral part of records.

Cooling components:

- Molecular mesh activated-alumina filter dryer;
- Flow and humidity indicator. The key is shown directly on the indicator glass;
- Thermostatic valve with external equalization and integrated MOP function;
- Thermostatic el. valve with step by step engine and dedicated el.driver to obtain the maximum efficiency of the cooling circuit and the best optimization of the functioning parameters;
- Reverse cycle valve (heat pump only);
- Unidirectional valve (heat pump only);
- High and low pressure switch;
- Schrader valves for checks, access and/or maintenance;
- Safety valve refrigerating side.

Electric control board: The electric control board is constructed and wired in accordance with Directives 2014/35/UE and 2014/30/UE and related standards. The board may be accessed through a door after the main switch has been put off. All the remote controls use 24 V signals powered by an insulating transformer situated on the electric control board. A T control kit comprising a thermostat and an auxiliary fan is available on request. The protection rating of the unit is IP 43.

NOTE: the mechanical safety devices such as the high pressure switch are of the kind that trigger directly; their efficiency will not be affected by any faults occurring in the microprocessor control circuit. in compliance with 2014/68/UE PED.

Control microprocessor: the microprocessor built into the unit allows the different operating parameters to be controlled from a set of pushbuttons situated on the electric control board:

- Switching on/off of compressor to maintain the temperature set point of the chiller inlet water temperature;
- Alarm management:
 - High / low pressure;
 - Antifreeze;
 - Flow switch;
 - Pump alarm;
- Alarm signalling;
- Displaying of operating parameters;
- Evaporator antifreeze protection;
- Management of maximum number of compressor start-ups;
- Serial output management (optional) RS232, RS485;
- Phase sequence error [Not displayed by the μ P, but prevents the compressor from starting up].

[ref. Microprocessor control manual for further details]

 **WARNING**

The technical data of the manual refer to the standard range, without optional devices, and are subject to changes without prior notice aimed at improving the product.

3.4 Main technical specifications

For the main technical data of the range ENW see Product Document.

4 SAFETY PRESCRIPTIONS

4.1 General safety rules

4.1.1 Thoroughly know the unit

The unit must only be used by qualified personnel, who are expected to know the arrangement and function of all controls, instruments, indicators, indicator lights and various data plates.

4.1.2 Wear protective clothing

Each operator must use personal protective equipment such as gloves, headgear, safety goggles, safety shoes, and hearing protection.



4.1.3 Use safety equipment

A first aid kit and a fire extinguisher must be placed near the unit.

The extinguisher must always be fully loaded. Use it according to the Standards in force.



4.1.4 Warnings for inspections and maintenance

Display a sign with the warning: "INSPECTION IN PROGRESS" on all sides of the unit.

Check the unit carefully following the list of operations contained in this manual.



4.2 General precautions

The Machinery Directive 2006/42/EC provides the following definitions (Annex 1.1.1.1):

DANGER ZONE: any area next to and/or inside a machine, where the presence of an exposed person constitutes a risk for the safety and health of said person.

EXPOSED PERSON: any person found entirely or partially within a danger zone.

OPERATOR: the person (or persons) appointed to install, set up, adjust, maintain, clean, repair and transport the machine.

WARNING

- Before carrying out any operation or maintenance on the unit it is mandatory to read and follow the instructions given in the use and maintenance manual. During the actual work, it would be too late: any not recommended or wrong operation could then cause serious damage to people or property.
- The employer must inform in detail all operators about the risks of accidents and particularly about risks related to noise, required personal protective devices and general accident prevention rules provided by laws or international standards and national standards in the Country of destination of the unit.

- All operators must comply with the international accident prevention standards and standards in force in the country of destination of the unit.
- Please be reminded that the European Union has issued some directives concerning the safety and health of workers, among which the directives 89/391/EEC, 89/686/EEC, 89/654/EEC, 2009/104/EC, 89/656/EEC, 2003/10/EC, 92/58/EEC and 92/57/EEC that each employer has an obligation to observe and to enforce. In the event that the unit is installed outside the European union, always refer to the regulations in force in the country of installation.
- Before starting any work on the unit, each operator must be perfectly familiar with its operation and its controls, and have read and understood all the information contained in this manual.

ATTENTION

It is forbidden to tamper with or replace parts of the unit unless this has been expressly authorised by the MANUFACTURER.

The use of accessories, tools, consumables or spare parts other than those recommended by the MANUFACTURER and/or specified in this manual may be a hazard to operators and/or damage the unit.

Any alteration of the unit not expressly authorised by the MANUFACTURER shall not imply any civil or criminal liability for the manufacturing company.

WARNING

- It is strictly forbidden to remove or tamper with any safety devices.
- Any installation, ordinary and extraordinary maintenance operations must be carried out with the unit stopped and without power supply.
- Once the unit has been cleaned, the operator must check that there are no worn or damaged parts or parts that are not safely fixed, or if this is the case, ask the maintenance staff to fix the problem.
- Special attention must be paid to the state of repair of the pressurised pipes or other parts exposed to wear. It must also be ensured that there are no leaks of fluid, or other dangerous substances.
- In these cases, it is forbidden for the operator to restart the unit before the situation has been remedied.
- If any of these occurrences are detected, the operator, before leaving the unit unattended, must display a warning sign indicating that maintenance is in progress and it is forbidden to start the unit.
- The use of flammable fluids in cleaning operations is prohibited.
- Periodically check the condition of the data plates and arrange, if necessary, for them to be restored.
- The operator work place must be kept clean, tidy and free from any objects that may limit unhindered movement.
- Operators should avoid operating the device from unsafe, uncomfortable positions that may affect their balance.
- Operators must be aware of possible risks of entrapment and entanglement of clothes and/or hair in moving parts; it is recommended to wear caps over long hair.
- Wearing chains, bracelets and rings can also be dangerous.

- The workplace must be adequately lit for the intended operations. Insufficient or excessively bright lighting can imply safety risks.
- Ensure adequate ventilation to the installation room to protect against any refrigerant leaks.
- The instructions, accident-prevention rules and warnings contained in this manual must be observed at all times.

4.2.1 Safety information

The units have been designed and built according to the current state of the art and the technical rules currently applicable to fluid chillers and heat pumps intended for cooling water or water and anti-freezing agent mixtures, for housing air conditioning and industrial cooling systems. Compliance with the laws, provisions, prescriptions, orders and directives in force for these machines has been ensured.

The materials and the equipment parts used, as well as the production, quality assurance and control processes meet the highest safety and reliability requirements.

By using them for the purposes specified in this user manual, by operating them with the required diligence and performing accurate maintenance and overhauling in a workmanlike manner, consistent performance and functionality and durability can be ensured.

4.2.2 Accident prevention

The MANUFACTURER cannot be held liable for accidents caused when using the unit, due to the user not complying with laws, provisions, regulations and standards in force regarding fluid chillers and heat pumps.

4.2.3 Operational safety

The MANUFACTURER will not be responsible in case of malfunctions and damage if the unit:

- it is used for purposes other than those for which it is intended;
- it is not operated and maintained according to the service standards specified further on in this manual;
- it does not regularly and consistently receive maintenance as prescribed or non-original spare parts are used;
- is modified or some components are replaced without the MANUFACTURER's written authorisation, especially when the effectiveness of the safety systems has been altered or minimised on purpose;
- it is used outside the permissible temperature range.

4.2.4 Residual risk areas

DANGER

In some areas of the unit there are some residual risks that could not be eliminated during the design phase nor isolated with guards due to the unit's operating characteristics. Each operator must be aware of the residual risks present in this unit in order to prevent any accidents.



- A** Danger of fire
- B** Danger of explosion due to the presence of pressurised circuits
- C** Danger of pollution due to the presence of refrigerant in the circuit
- D** Danger of burns due to the presence of high temperature pipes



 **WARNING**

In order to avoid the risks listed above it is essentially important to:

- set the control panel according to the manufacturer's instructions;
- to avoid the risk of impact or abrasion in the fan area, cut off the power to the unit before intervening;
- not place metal objects inside the electrical control panel;
- not store flammable materials near the machine;
- not alter any component of the refrigerant circuit;
- not let the machine work outside the limits indicated by the manufacturer;
- dispose of all the materials that make up the machine correctly, use suitable equipment for the recovery of the refrigerant gas (see chapter 13 Retiring the unit p. 44);

4.3 Location of safety data plates



<p>1</p> <p>A. Warning: danger due to poor familiarity with all the functions of the unit and the resulting risks. B. Read the use and maintenance manual carefully before operating the unit.</p>	
<p>2</p> <p>Electric power supply data plate</p>	
<p>3</p> <p>A. Danger: hot parts. B. Danger: live parts. C. Danger of burns. D. Danger of cutting injuries in the finned exchangers area.</p>	
<p>4</p> <p>Anchor points for lifting</p>	
<p>5</p> <p>Refrigerating liquid</p>	
<p>6</p> <p>Charge connection without core valve</p>	

4.4 Maintenance precautions

4.4.1 Tools

Personal injury is prevented by not using worn or damaged, low quality or makeshift tools.

ATTENTION

If tools not recommended or modified without authorisation are used, the manufacturer will no longer be liable for damages caused.

4.4.2 Personnel

Ordinary maintenance prescribed in this manual must only be performed by authorised and trained personnel. For the maintenance or overhauling of components not specified in this manual, contact the MANUFACTURER.

4.4.3 Keep the unit clean

Oil and grease stains, misplaced tools or broken pieces are harmful to people as they can cause slipping or falls. Always keep the area where the unit is installed clean and tidy.

Do not use diesel fuel, oil or solvents to clean the unit as the first two leave an oily film that makes it easier for dust to stick, while solvents (even milder ones) damage the paint finish and cause rusting.

If a water jet hits the inside of electrical equipment, in addition to causing contact oxidation, it may cause the unit malfunction.

For this reason, do not use water or steam jets on sensors, connectors or any electrical parts.

4.4.4 Care and maintenance

The cause of damages and accidents is often attributable to wrong maintenance, such as:

- no water in the circuit;
- incorrect percentage of anti-freezing agent in the hydraulic circuit;
- inadequate refrigerant;
- poor cleaning in the unit setting;
- circuit inefficiency (damage to the exchangers, pipe connections, tightening of pipes, screws, etc.).

Carry out maintenance work as required: this is also critical for your own safety.

Never postpone scheduled repairs.

Only assign skilled or authorised personnel to repair tasks.

Always observe the following safety rules, even when you are thoroughly familiar with the operations involved:

- always keep the unit and the surrounding area clean;
- before beginning to work, check the perfect efficiency of protective devices;
- make sure that no unqualified or not specially appointed persons enter the unit operating area.

4.5 Precautions in case of refrigerant leakage

In case the unit is charged with an A2L classified refrigerant, (low flammable refrigerant), the unit is provided with one refrigerant leakage sensor inside each compressor box (if present) and inside all separated sections of the electrical box.

The following safety chain is applied: EVENT - ACTION - SIGNAL

Each sensor is set on two different concentration thresholds. The threshold is depending on refrigerant type, and listed in the table below:

Refrigerant	Classification	Low level threshold	High level threshold
R454B	A2L	900 ppm	1800 ppm

The following image and table describe the safety chain EVENT - ACTION - SIGNAL

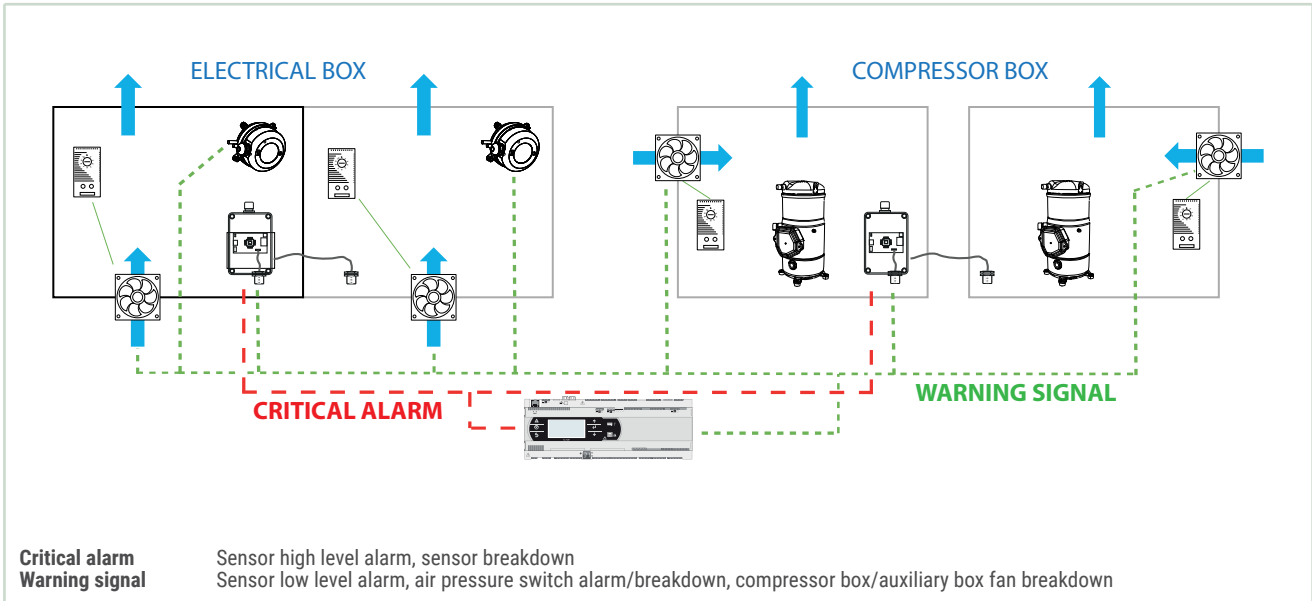

EVENT	ACTION	SIGNAL
Compressor box fan alarm fault	Electrical box fans activation (when $T_{air} \leq T$ limit)	Dedicated warning signal
Underpressure inside electrical panel alarm/fault	Compressor box fans activation	Dedicated warning signal
Low level alarm	Compressor box fans activation Electrical box fans activation (when $T_{air} \leq T$ limit)	Dedicated warning signal
Refrigerant sensor fault	Switch off all the unit (electrical supply still present)	General serious alarm + Dedicated serious alarm
High level alarm	Switch off all the unit (electrical supply still present)	General serious alarm + Dedicated serious alarm

⚠ DANGER

Refrigerant safety devices are not active when the unit is not powered: risk of refrigerant presence in the electrical panel. Check any refrigerant leaks with a suitable device before starting the unit.

🔊 WARNING

Follow the instructions below in the event of a refrigerant leak signal from the sensors installed on the machine or possibly present near the machine:

- In case of low level alarm, contact technical support.
- Do not stand in the vicinity of the machine.

It is necessary to have a remote refrigerant alarm signal, so that it is not necessary to approach the machine in the event of an alarm. This remote signal can be performed:

- Via remote display, available as an option and available at any time by contacting the After-sales center;
- By reading the unit alarms via remote communication (e.g. via Modbus or Ethernet) and by remotely setting up a specific danger signal far from the unit to activate in the event of an alarm.

⚠ ATTENTION

In case of serious alarm:

- Remove voltage from the unit, keeping the dedicated alarm signal via wired contact active (see wiring diagram).
- Call a service centre for assistance.

Technical assistance must:

- Well ventilate all the closed compartments of the machine well for at least 5 minutes, before energizing.
- Check the cooling circuit for leaks.
- Once the circuit is set up and the refrigerant charge is restored, close the compartments and power up the chiller, if there are no alarms, the machine can be restarted.

⚠ DANGER

The safety of the installation environment outside unit boundaries is entrusted to the technical manager of the system.

The installation site must comply with the design requirements of EN378-1. If classified as a “machinery room” or in any case “closed environment” according to the definition of the legislation, the following points must be respected:

- Ensure the quality and minimum quantity of ventilation air to the machine, for example by installing a leak detector to monitor the presence of flammable gas in air. In the event that the concentration of the refrigerant exceeds 25% of the LFL (low flammability limit), an alarm must be activated together with mechanical ventilation and system shutdown;
- Installation of an emergency ventilation system which is activated in the event of leakage detection inside the room; if the fan is on suction side, it must comply with the requirements for installation in areas at risk of fire;
- Avoid any contact between the refrigerant and surfaces that exceed 80% of its auto-ignition temperature.

5 TRANSPORT, INSPECTION, HANDLING, DIMENSIONS AND POSITIONING OF THE UNIT

5.1 Transport

In order not to damage the structure and components, the units ENW must be fixed to the transport vehicle using the

supports shown in the following figure. The image on the left refers to cases including accessories.

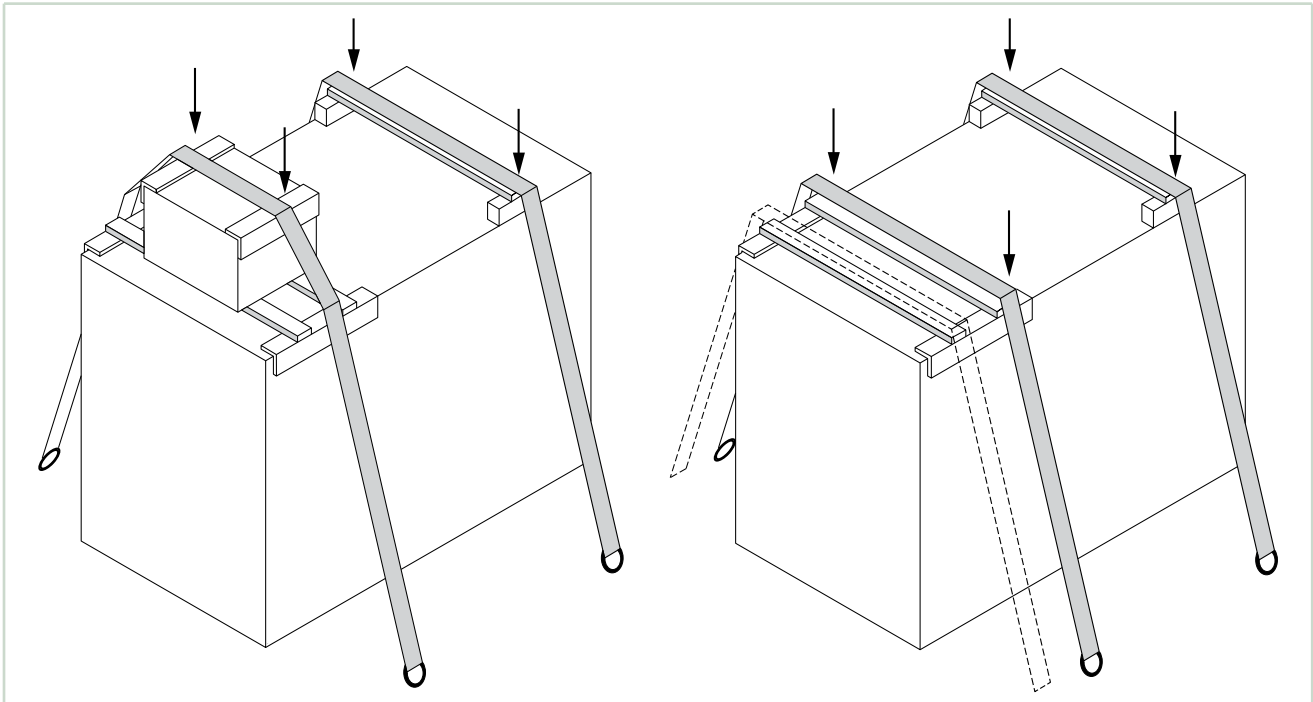

5.2 Inspection

Upon receiving the unit, check its integrity: the machine has left the factory in perfect condition; any damage must be immediately reported to the forwarder and noted on the Delivery report before signing it.

The manufacturers or their agents must be informed as soon as possible about the extent of the damage. The Customer must submit a written report for any significant damage.

Upon receiving the unit, check its integrity: the machine has left the factory in perfect condition; any damage must be immediately reported to the forwarder and noted on the Delivery report before signing it.

The manufacturer or its agent must be promptly notified of the extent of the damage.

The Customer must submit a written report describing every significant sign of damage.

5.3 Conveyance

During the unloading and positioning of the unit, be extremely careful to avoid bumps and knocks or sudden movements. Handling must be carried out carefully and gently, avoiding to apply pressure to any machine components. The unit shall be lifted using seamless pipes - ref. EN10255 S195T - in steel $\varnothing 1\frac{1}{2}$ " GAS at least 3 mm thick inserted into the round holes provided in the base rails (a) and marked with the special stickers.

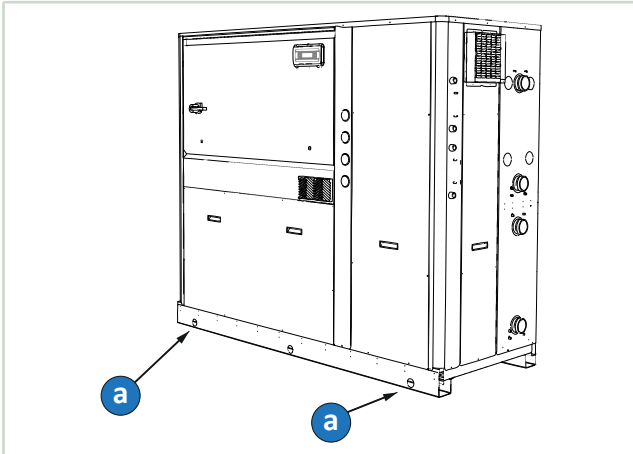

The pipes that must protrude by at least 300 mm from each end will be harnessed with identical ropes, secured to the lifting hook (provide fasteners at the ends of the pipes in order to avoid that, due to the applied weight, the rope slips off the pipe).

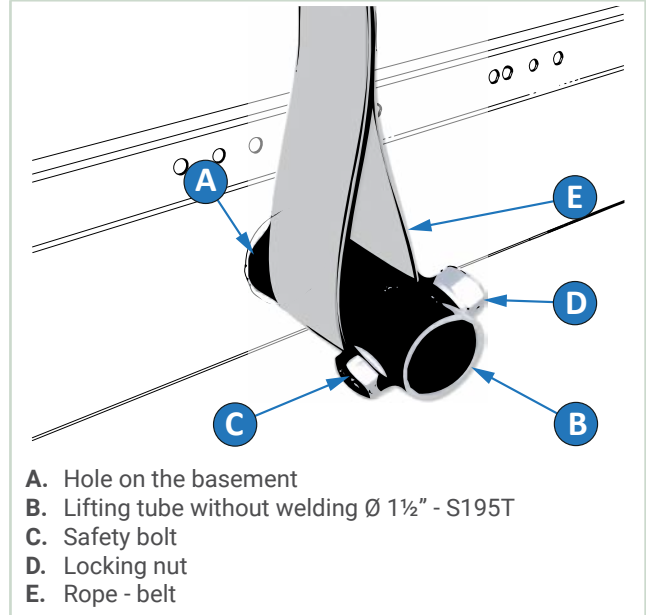

Use ropes or belts of adequate length and strength and spacer bars to avoid damaging the sides and top of the unit.

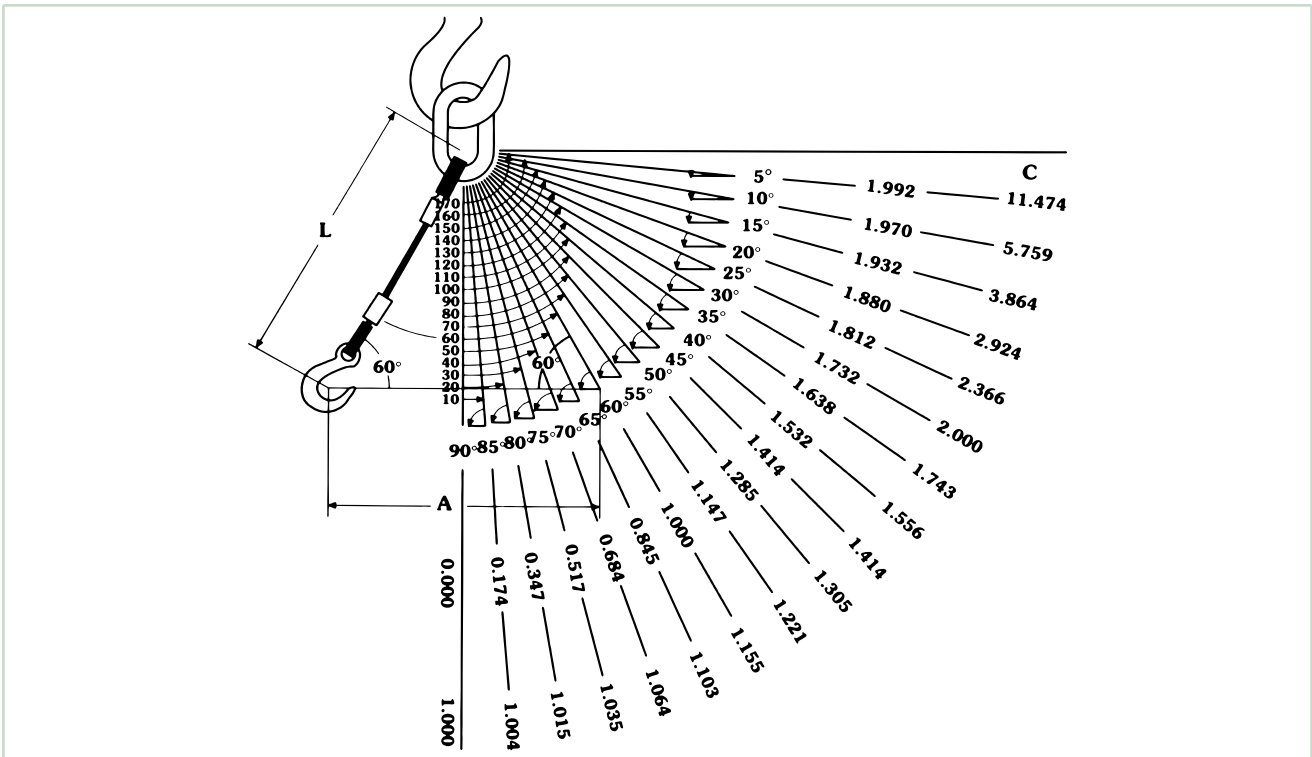

Vertex Angle (°)	0	10	20	30	40	50	60	70	80	90	100	110	120	130	140	150	160	170
Load increase factor	1	1.004	1.015	1.035	1.064	1.103	1.155	1.221	1.305	1.414	1.556	1.743	2.000	2.336	2.924	3.864	5.759	11.474

 **ATTENTION**

In all lifting operations make sure that the unit is securely anchored in order to prevent accidental falls or overturning.

 **ATTENTION**

The use of tie rods having a vertex angle with respect to the vertical line greater than 60° is not recommended; beyond

this limit, the capacity of the tie rod varies considerably for each small change in the angle or according to general conditions of use.

Introduction
ENW
 **WARNING**

CAREFULLY READ THIS MANUAL BEFORE USING THE UNIT.

 **DECLARATION OF CONFORMITY**

The declaration of conformity is attached separately to the documents on board the unit, usually placed inside the electrical compartment.

Dear Customer,

Thanking you for choosing our products, we are pleased to provide you this manual for the correct use of equipment.

Please read the recommendations described in the following pages carefully and keep the manual available to personnel who will be responsible for managing and maintaining the unit.

Our company is at your complete disposal for any and all questions that you should require both in the unit starting phase and at any time of its utilization.

Should scheduled and unscheduled maintenance be necessary, please contact our After-sales Technical Service for assistance and spare parts.

Please find here attached our direct contacts in case you may need assistance:



ENEREN S.r.l.
Viale Spagna, 31/33
35020 Tribano (Pd) ITALY
Tel + 39 049 9271513
Fax + 39 049 9588522
e-mail : info@eneren.it



049-9271513



support@eneren.it

Start-up instructions

1 YOUR INSTALLATION

All the tips required for a perfect installation of the equipment can be found in the installation manual.
It is important to place a net filter at all water circuit inlets.

The filter must be made of stainless steel with a mesh that does not exceed 1 mm.

2 REQUIRED ACCESSORIES FOR A PROPER INSTALLATION OF THE UNIT

For the proper operation of the unit and for the validity of the warranty, the installation of the following hydraulic components will be necessary:

- Y-strainers in the inlet pipes to the unit;
- anti-vibration couplings in each pipe connected to the unit;

- appropriately dimensioned safety valves on each circuit of the system;
- appropriately dimensioned expansion vessels on each circuit of the system.

3 FIRST START-UP

With at least 15 working days in advance, send the machine start request via email or fax to the following contact ENEREN:

Fax. 049 9588522

e-mail: support@eneren.it

Tel. 049 9271513

ENEREN Assistance will organize the intervention by putting you in contact with Authorized Technical Assistance Center of the area.

All the preliminary checks and testing of the machine will be carried out together with your staff.
Your staff will be given instructions for the correct running of the machine.

4 WARRANTY ISSUE

For the warranty to be valid, the first start-up by an Authorized Technical Assistance Center is mandatory.
After testing, the Authorized Technical Assistance Center will issue a valid test certificate for the machine warranty.

5.4 Unpacking

The unit packaging must be carefully removed avoiding possible damage to the machine; the materials that make up the packaging are of a different kinds: wood, cardboard, nylon, etc.

It is good practice to collect them separately and deliver them for disposal or recycling to specialised disposal companies - thus reducing their environmental impact.

5.5 Siting

Check the following points to select the best installation setting for the unit and its connections:

- Size and origin of water pipes;
- power supply location;
- accessibility for maintenance or repairs;
- solidity of the supporting surface.

All models belonging to the ENW series are designed and built for indoor installation. As special care has been taken in the sound insulation and sealing of the components and

hot parts in general, they need not be installed in dedicated rooms.

ATTENTION

It is advisable to place a rigid rubber strip between the base frame and the supporting surface.

5.6 Installation clearance requirements

In the case of units with a remote condenser, the plumbing and cooling connections are provided on the top of the unit. This allows the chiller to be placed practically against the rear wall. It is nonetheless of fundamental importance to assure the following service spaces:

- back side: min. 0 metres (except the 2 last sizes)
- electric control board side: min. 1,0 metre to guarantee access for inspection and/or maintenance of cooling components
- lateral part: min. 0.5 metre for extraordinary maintenance
- top side: min. 1.0 metre for adequate connection to the external hydraulic and cooling piping

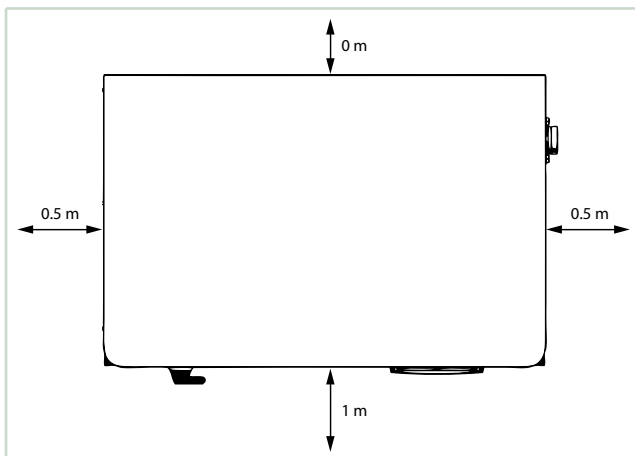

DANGER

During normal operation, human traffic in the area around the machine must be prevented up to at least the required buffer spaces.

ATTENTION

In the event of installing several machines close together, the clearances between the machines must be double those indicated in this manual and/or in the attached dimensional drawings.

6 PLUMBING AND ELECTRICAL CONNECTIONS

6.1 Hydraulic connections

6.1.1 General guidelines for plumbing connections

When you are getting ready to set up the water circuit for the evaporator you should follow the directions below and in any case make sure you comply with national or local regulations (use the diagrams included in this manual as your reference).

ATTENTION

Connect the pipes to the chiller using flexible couplings to prevent the transmission of vibrations and to compensate thermal expansions. For the types and size of the water and cooling connections (versions with remote condenser only) refer to the table of technical data.

Install the following components on the piping:

- temperature and pressure indicators for routine maintenance and monitoring of the unit. Checking the pressure on the water side will enable you to verify whether the expansion tank is working efficiently and to promptly detect any water leaks within the equipment;
- traps on incoming and outgoing pipes for temperature measurements, which can provide a direct reading of the operating temperatures. Temperature readings can in any case be obtained from the microprocessor installed on the unit;
- regulating valves (gate valves) for isolating the unit from the water circuit during maintenance work;
- metal mesh filter (incoming pipes), with a mesh not to exceed 1 mm, to protect the exchanger from scale or impurities present in the pipes. This prescription is particularly important at first start-up;
- air vent valves, to be placed at the highest points of the water circuit for the purpose of bleeding air. [The internal pipes of the unit are fitted with small manual air vent valves for bleeding the unit itself: **this operation may only be carried out when the unit is disconnected from the power supply**];
- drainage valve and, where necessary, a drainage tank for emptying out the equipment for maintenance purposes or when the unit is taken out of service at the end of the season.

6.1.2 Water connection to the evaporator

WARNING

All ENW units are not provided with an internal water group, but it will be installed on the outside of the unit.

ATTENTION

It is critically important that water inlet occurs at the connection marked with the words "Water Inlet".

Otherwise the evaporator would be exposed to the risk of freezing since the antifreeze thermostat would not be able

to perform its function; moreover the reverse cycle would not be respected in the cooling mode, resulting in additional risks of malfunctioning. This position does not enable the operation of the water flow control device. The dimensions and position of plumbing connections are shown in the dimension tables at the end of the manual.

WARNING

The water circuit must be set up in such a way as to guarantee that the nominal flow rate of the water supplied to the evaporator remains constant (+/- 15%) in all operating conditions. The compressors work intermittently, since the chilling requirements of the user generally do not coincide with the compressor output. In systems containing little water, where the thermal inertia of the water is lower, it is a good idea to check that the water content in the section delivering to users satisfies the condition below:

$$V = \frac{C_c \times \Delta \tau}{\rho \times Sh \times \Delta T \times N_s}$$

V	water content in the user section [m3]
Sh	fluid specific heat [J/(kg/°C)]
ρ	fluid density [kg/m3]
Δτ	minimum time between 2 restarts of the compressors [s]
ΔT	permitted waterT differential [°C]
C_c	refrigerating power [W]
N_s	No. of partial loading steps

The following figure shows the integrated and balanced effect of the storage tank. Its function helps ensure accurate temperature control according to the environmental parameters of the connected groups.

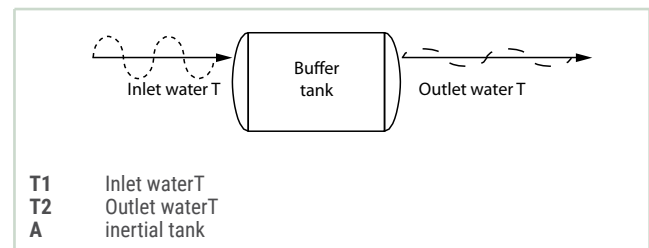

ATTENTION

A standard feature of ENW units is a device for controlling the flow rate (flow switch or differential pressure switch) in the water circuit in the immediate vicinity of the evaporator.

ATTENTION

Any tampering with said device will immediately invalidate the warranty.

ATTENTION

It is advisable to install a metal mesh filter on the inlet water pipe.

⚠ ATTENTION

When making the plumbing connections, make sure there are no open flames in proximity to or inside the unit.

6.1.3 Instructions for the filling up of the tank and/or the pump(s) (if present)

⚠ ATTENTION

The tank is not planned to resist to a depression greater than -0,15 Bar, so pay attention to the fact that the suction pressure of the pump, where the expansion tank is positioned, has to be always greater than 0,5 Bar with the pump in operation: this fact also contributes to reduce any risks concerning the cavitation of the pump.

It is of fundamental importance for the installer to follow and check the instructions written below stepwise, so as to avoid every kind of risks concerning the implosion of the tank or the cavitation of the pump:

- A. Empty the expansion tank until the pressure is 0,5 Bar;
- B. Charge the system and pressurize it until about + 1 Bar in suction, pump side (with pump not working);
- C. Allow air to escape from the system;
- D. Check the suction pressure of the pump (about 1 Bar) and start the system;
- E. Stop the pump after 15-30 minutes and repeat from point c) until there are no more noises caused by air in the system.

6.1.4 Refrigerant charge

⚠ DANGER

Before carrying out any operation with the refrigerant, it is recommended to read the special safety data sheet (MSDS). The refrigerants used in the entire Eneren product range are R410A R454B.

These have the following characteristics:

- **TOXICITY**, the refrigerants mentioned above all belong to group A according to the standard 34 ASHRAE; this group includes all refrigerants that are found not toxic for concentrations equal to or lower than 400 ppm.
- **FLAMMABILITY**, according to the standard 34 ASHRAE, refrigerant R-410A is classified in the safety group A1, i.e. non-flammable at a pressure of 1 atm (101.3 kPa) and 18°C. R-454B is classified in the A2L safety group, i.e. mildly flammable at 1 atm pressure (101.3 kPa) and 18°C.
- **CATEGORY**, the refrigerants used are fluids of category II according to the PED 2014/68/EU directive and therefore, they are not dangerous.

The area must be immediately evacuated if there is a constant leak of refrigerant gas. The gases concentrate near the floor, thereby restricting the availability of oxygen. Once evacuated, the area must be ventilated with fans or blowers in order to circulate the air at floor level.

For loading operations, follow the procedure described below:

- connect the refrigerant gas cylinder to the 1/4 SAE male filler outlet located on the liquid line, making sure that there are no impurities, moisture and/or incondensable gases in the inlet pipes;

- load liquid state charge until 75% of the total charge has been introduced;
- then connect to the intake on the suction line and complete liquid charge loading until no more bubbles appear on the liquid viewer and the operating values are reached that are indicated in the paragraph 8.7 Refrigerant charge checks p. 32.

⚠ ATTENTION

A unit originally filled at the factory with a refrigerant type cannot be filled with different refrigerants without a written permission from manufacturer.

⚠ ATTENTION

If the (mildly flammable) R454B is used, it is recommended to provide all the safety devices required by law during installation. In case of indoor installation, contact the manufacturer.

⚠ ATTENTION

Refer to paragraph 13.2 Environment protection p. 44 contained in this document.

6.2 Electrical connections

⚠ ATTENTION

Before carrying out any operation on electrical parts, make sure that there is no applied voltage.

Check that the mains electricity supply is compatible with the specifications (voltage, number of phases, frequency) shown on the unit rating plate.

The power connection for single-phase loads is to be made with a three-pole cable and "N" wire at the centre of the star (optional: power supply w/o neutral).

⚠ ATTENTION

The size of the cable and line protections must conform to the specifications provided in the wiring diagram.

The supply voltage may not undergo fluctuations exceeding ±5% and the unbalance between phases must always be below 2%.

⚠ ATTENTION

Operation must occur within the above voltage value range, otherwise, the guarantee will no longer be valid.

Carry out the electrical connections following the wiring diagram provided with the unit, as well as current regulations.

⚠ ATTENTION

An earth connection is mandatory. The installer must connect the earthing wire using the earthing terminal situated on the electric control board (yellow and green wire).

The power supply to the control circuit is shunted from the power line through an insulating transformer situated on the electric control board.

The control circuit is protected by suitable fuses or automatic breakers depending on the unit size.

6.2.1 Electrical connections of the circulation pump (if present)

For all ENW units a clean contact is provided on the electric board for powering a low-voltage remote control used to start the pump.

ATTENTION

If it is an integral part of the supply, the pump must be started before the chiller and stopped after the latter (minimum recommended delay: 60 seconds). If it is connected to the terminal in the electric control board, this function is carried out by the built-in microprocessor.

6.2.2 Remote controls

WARNING

If you wish to include a remote control for switching the unit on and off, you must remove the bridge between the contacts

indicated in the wiring diagram and connect the remote ON/OFF control to the terminals themselves [see annexed wiring diagram], then enable the "REMOTE" function by means of the switch provided in the electric board.

6.2.3 Summer Winter Remote Switching [Heat pump version]

If you wish to include a remote control for summer/winter switching of the unit, you must remove the bridge between the contacts indicated in the wiring diagram and connect the remote ON/OFF control to the terminals themselves [see annexed wiring diagram], then enable the "REMOTE" function by means of the switch provided in the electric board.

6.3 Hydraulic and refrigeration diagrams

6.3.1 Water circuit - only cooling

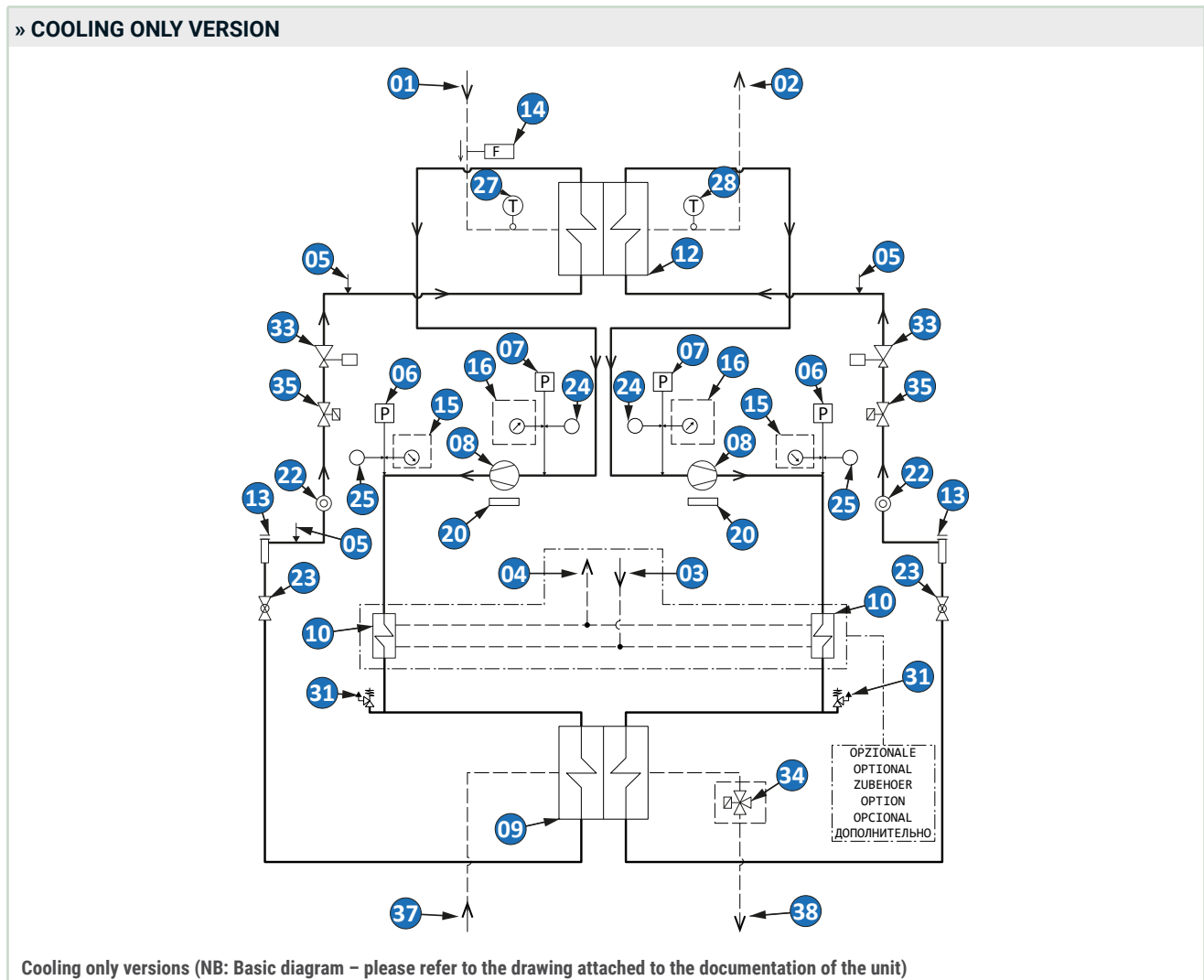

1	Chilled water inlet	11	Buffer tank	21	Energy-saving coil	31	Safety valve
2	Chilled water outlet	12	Evaporator	22	Sight glass	32	Water safety valve
3	De-superheater water inlet	13	Filter dryer	23	Shut-off valve	33	Thermostatic valve
4	De-superheated water outlet	14	Flow switch	24	Evaporating pressure probe	34	Free-cooling valve
5	Charge connection	15	High pressure gauge	25	Condensing pressure probe	35	Solenoid valve
6	High pressure switch	16	Low pressure gauge	26	Expansion tank	36	Partialization solenoid valve
7	Low pressure switch	17	Fan motor	27	Water inlet temperature sensor	37	Condensing water inlet
8	Compressor	18	Chilled water circulation pump	28	Water outlet temperature sensor	38	Condensing water outlet
9	Condenser	19	Gate valve	29	Outdoor air temperature sensor	39	4 - way valve
10	De-superheater	20	Crankcase heater	30	Check valve	40	Liquid receiver
-	-	-	-	-	-	41	Electronic expansion valve

6.3.2 Water circuit - reversible heat pump

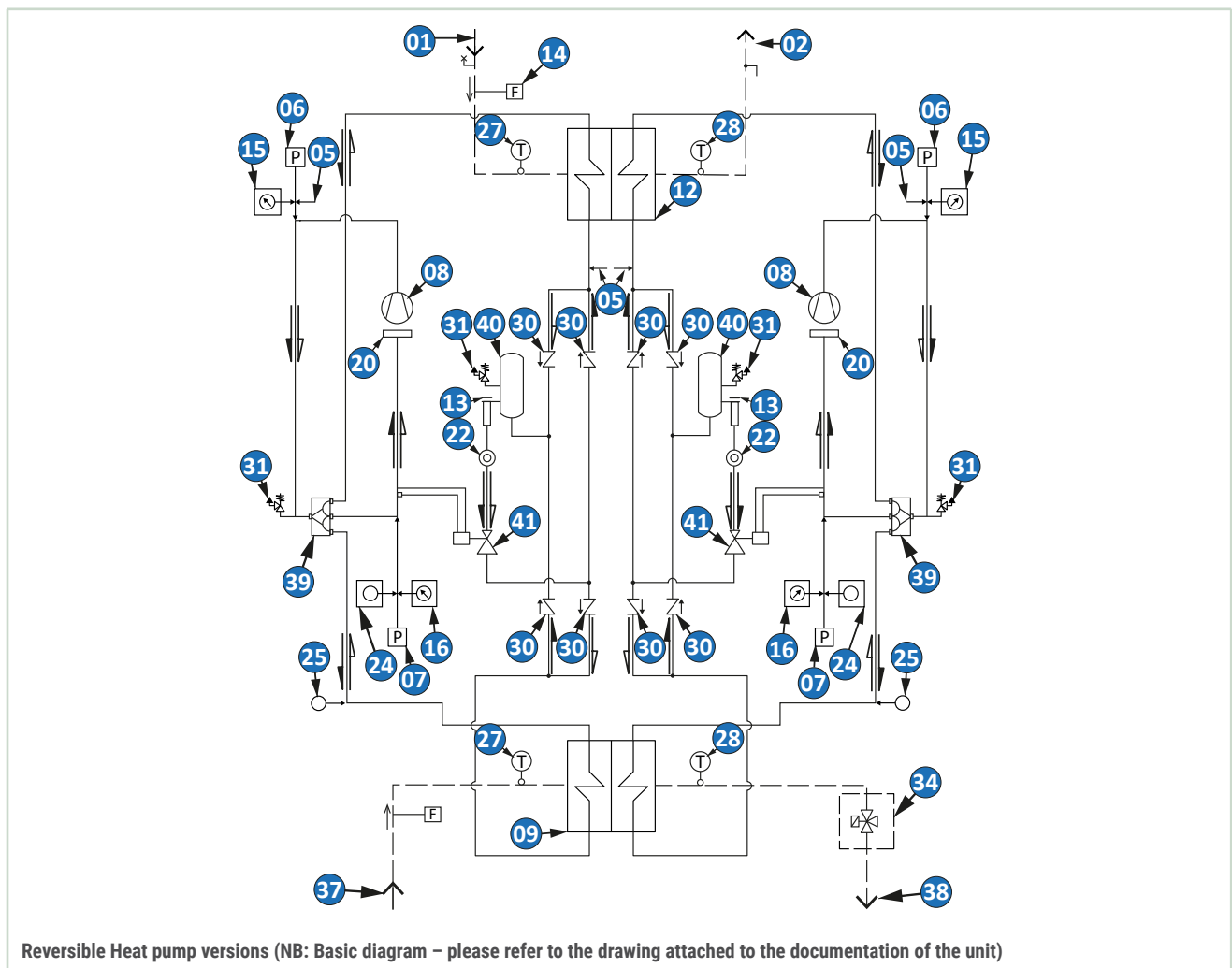

1	Chilled water inlet	11	Buffer tank	21	Energy-saving coil	31	Safety valve
2	Chilled water outlet	12	Evaporator	22	Sight glass	32	Water safety valve
3	De-superheater water inlet	13	Filter dryer	23	Shut-off valve	33	Thermostatic valve
4	De-superheater water outlet	14	Flow switch	24	Evaporating pressure probe	34	Condensation control valve
5	Charge connection	15	High pressure gauge	25	Condensing pressure probe	35	Solenoid valve
6	High pressure switch	16	Low pressure gauge	26	Expansion tank	36	Partialization solenoid valve
7	Low pressure switch	17	Fan motor	27	Water inlet temperature sensor	37	Condensing water inlet
8	Compressor	18	Chilled water circulation pump	28	Water outlet temperature sensor	38	Condensing water outlet

9	Condenser	19	Gate valve	29	Outdoor air temperature sensor	39	4 - way valve
10	De-superheater	20	Crankcase heater	30	Check valve	40	Liquid receiver
-	-	-	-	-	-	41	Electronic expansion valve

7 MICROPROCESSOR CONTROL

 **WARNING**

To obtain access to all the information related to unit switching on and off, its use, the setting of the working set-point, the display of the alarms and all the parameters related to microprocessor control, possibly linked to customer specifications details, please refer to the dedicated "Microprocessor Manual", supplied with the unit.

8 START-UP

8.1 Preliminary checks

Before starting the unit it is necessary to carry out the following checks:

- if the unit is charged with R454B refrigerant, aerate all closed vanes before doing any action;
- check that all the taps in the cooling circuit are open (liquid line) and that the flow switch is closed, by entering the status menu of the digital inputs;
- remove the protective cap of the A2L sensor;
- check that electrical wiring has been carried out correctly and that all the terminals are tightened hard (see paragraph 6 PLUMBING AND ELECTRICAL CONNECTIONS p. 22);
- after checking that the unit is powered, check that voltage at the terminals complies with the value indicated on the silver label and the corresponding tolerance; then check that the yellow phase sequence relay light (if any) is lit. The phase sequence relay is marked RSF and failure to observe the sequence will not enable a machine start;
- make sure that there are no refrigerant leaks due to accidental impacts during transport and/or installation;
- check the correct power supply to the enclosure heaters - if any;
- check all air has been vented through the vents on the pumps.

WARNING

The introduction of compressor casing resistances, if any, must be done at least 12 hours before the first start-up; it then occurs automatically when the main disconnect switch is closed. They are intended to increase the temperature of the oil in the sump, thus limiting the amount of refrigerant dissolved in it and ensuring that the desired lubrication characteristics are preserved.

- To ensure the correct operation of the heating elements, check that the lower part of the compressors is hot and in any case, that it is at a temperature 10-15°C higher than ambient temperature.

A slight foaming [1-5 mm] of the oil at start-up (pressure drop => decrease in solubility %) is physiological and will not affect the reliability of the system.

- Check that the hydraulic connections have been performed correctly, in accordance with the indications on the data plates on-board the machine (correct inlet and outlet connectors). Please refer to paragraph 6.1 Hydraulic connections p. 22.
- Check that the hydraulic system has been vented, bleeding any residual air, filling it gradually and opening the venting devices at the top - which the installer must have prepared in advance.
- Check that all the conditions specified in this manual have been observed, among which the working limits and the characteristics of the heat transfer fluid, as will be explained further on.

8.2 Operating limits

Operating limits of ENW chillers in relation to the outlet water temperature and water dew point.

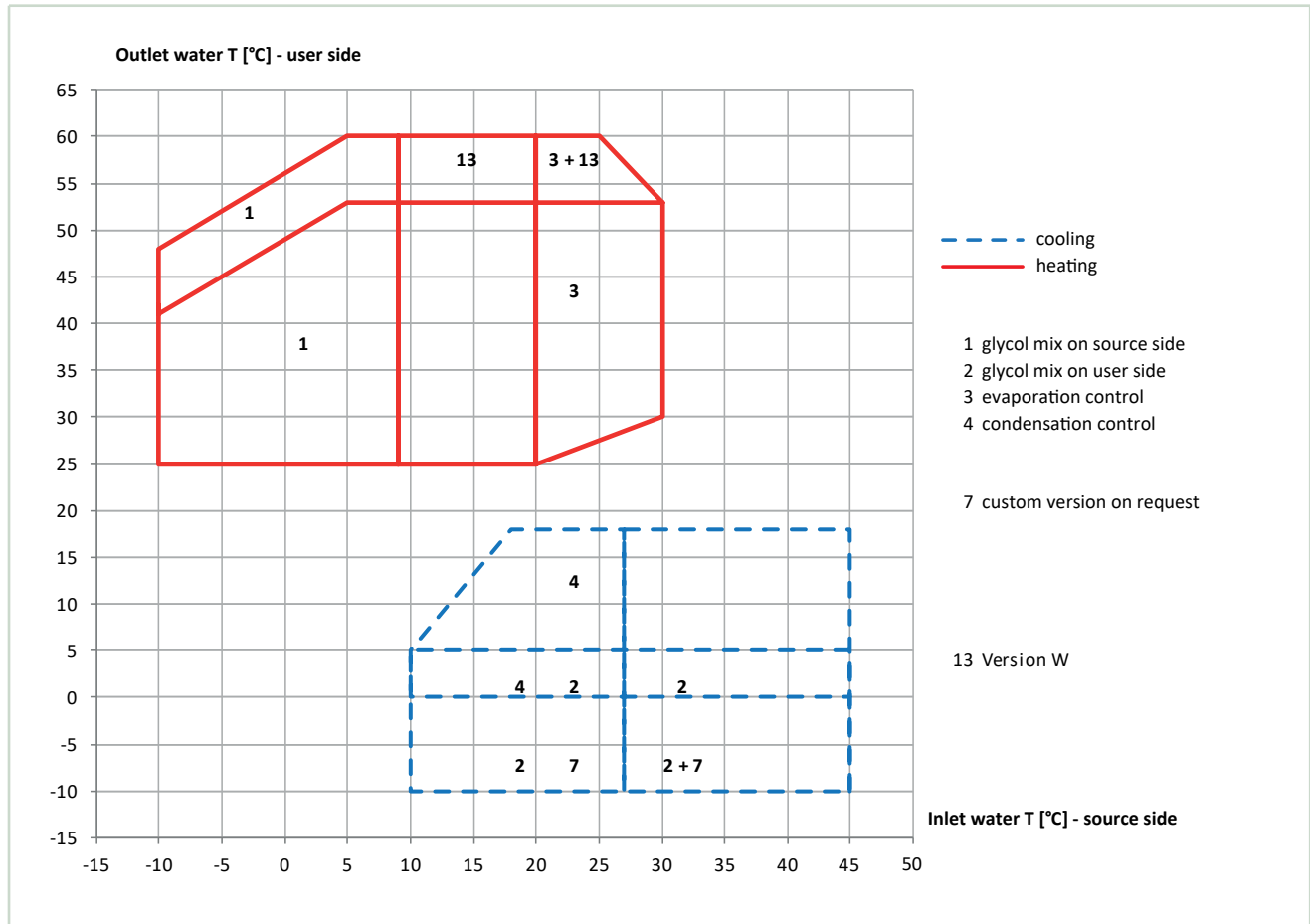

Applications with water T above the specified limits require the use of R134a refrigerant fluid (on request). For details please contact the local HiRef dealer.

» Cooling only unit

Water temperature	Minimum	Maximum	Notes
Evaporator inlet	10	25	Without antifreeze products
Condenser inlet	15	45	Below 15°C the condensation pressure control is required

» Heat pump units

Water temperature	Minimum	Maximum	Notes
Evaporator inlet (cooling mode)	10	25	Without antifreeze products
Condenser inlet (cooling mode)	15	45	Below 15°C the condensation pressure control is required
Evaporator inlet (*) (heating mode)	15	45	Without antifreeze products
Condenser inlet (*) (heating mode)	12	25	Without antifreeze products

(*) in heat pump operation heat exchangers work on reverse function.

8.2.1 Glycol solutions

It is possible to produce water at temperatures below 5°C and as low as -10°C using glycol solutions that lower the freezing point according to the following table:

Minimum temperature of water produced	5 °C	2 °C	-1 °C	-5 °C	-10 °C
Percentage by weight of ethylene glycol	0 %	10 %	15 %	25 %	30 %
Mixture freezing temperature	0 °C	-4 °C	-8 °C	-14 °C	-18 °C

Given an equal volumetric flow rate of water, pressure drops will depend on the percentage of glycol, as shown in the following table:

Percentage by weight of ethylene glycol	0 %	10 %	15 %	25 %	30 %
Pressure drop change	0 %	+12 %	+21 %	+43 %	+55 %

8.2.2 Operating limits

Thermal carrying fluid	fluid water or glycolated water and antifreeze mixtures max. 35%
Maximum water operating pressure	3 bars
Maximum operating P – High pressure side	45 bar-r
Maximum operating T	45 °C
Minimum operating T	-10 °C
Maximum operating P – Low pressure side	29 bar-r (*)
Supply voltage	+/- 5% of rating plate voltage
Maximum stocking T	+50 °C
Minimum stocking T	-20 °C (limit imposed by the built-in electronic components)

(*) this value can be reached only in storage conditions and determines the refrigerant saturation pressure of 29 bar-r on the low pressure side of the circuit, a value which in fact defines the limits.

8.2.3 Water flow to the evaporator

The nominal flow rate is based on a thermal differential of 5° C between inlet and outlet water, in relation to the cooling capacity provided at the nominal water temperatures (12/7 °C). The maximum allowed flow rate is associated with a thermal differential of 3 °C. Higher flow rate values cause too big pressure drops.

The minimum allowed flow rate is associated with a thermal differential of 8 °C. Lower flow rates could cause excessively low evaporation temperatures, which would trigger the safety devices and cause the unit to stop.

8.2.4 Operating limits on desuperheater side

It is necessary to ensure that the desuperheater inlet temperature is always above 35°C and below 50°C. Temperature values below 35°C can cause problems for the correct operation of the unit.

8.3 Thermal carrying fluid

The units of the series ENW can work with mixtures of water and glycol, with percentages of the latter up to 40%.

% by weight of glycol	Freezing temperature of the mixture with ethylene glycol (°C)	Freezing temperature of the mixture with propylene glycol (°C)
0	0	0
10	-3	-3
15	-5	-5
20	-8	-7
25	-11	-10
30	-14	-13
40	-22	-21
50	-34	-33
60	-48	-51

ATTENTION

If the required amount of 40% glycol needs to be exceeded, or in any case, in conditions of use other than those prescribed by the following tables, please contact the design department for the required checks; doing otherwise will render the equipment warranty null and void.

ATTENTION

Using glycol is necessary in all cases in which the temperature of the heat transfer fluid drops below 5°C, i.e. even when the unit is switched off or only running in summer mode, should this temperature condition occur. This will prevent water freezing and the resulting internal damage to components.

The percentage of glycol must be selected according to the lowest expected temperature. In the following tables, the freezing temperatures of the mixture are given as a function of the glycol content and the recommended amount of glycol - respectively.

Minimum water production temperature	°C	5	2	1	-3	-6
Glycol percentage by weight	%	0%	10%	15%	25%	30%

The use of glycol will determine a change in terms of heating capacity, water flow and pressure drop. The corrective

factors to be used according to the percentage of glycol are shown in the following table.

Glycol percentage by weight	%	0%	10%	20%	30%	40%
ETHYLENE-BASED	Developed heat capacity correction factor	1,00	1,00	0,99	0,99	0,98
	Water flow rate correction factor	1,00	1,05	1,09	1,14	1,20
	Pressure drop correction factor	1,00	1,16	1,35	1,58	1,86
PROPYLENE-BASED	Developed heat capacity correction factor	1,00	1,00	0,98	0,97	0,96
	Water flow rate correction factor	1,00	1,02	1,04	1,07	1,10
	Pressure drop correction factor	1,00	1,11	1,31	1,53	1,78

8.4 Start-up instructions

Water connections:

- Warning: The chiller is charged with HFC R410A – Group II EN 378 refrigerant (non-hazardous substances) conforming to the requirements of EEC regulation 2037/00.
- When making the plumbing connections, be sure to apply the inlet and outlet connections as indicated. In particular, be very careful not to invert condenser and evaporator circuits.
- Apply gate valves on the water side so that the chiller may be isolated from the plumbing system and install a mesh filter (accessible for inspection) on both the evaporator and condenser sides.
- Fill the hydraulic circuit, making sure to expel all the air present inside.

Electrical connections:

- Put on the main switch, turn the ½-turn locking screws of the electric enclosure and open it.
- Introduce the power cable 400/3/50+N through the hole provided on the left side of the unit and secure it in place with the cable holder.
- Connect the power supply and the earth cable to the terminals of the main disconnect switch.
- Put off switch “QF” of the compressor so as to be sure it will not start running in the wrong direction in the case of a phase sequence error.
- Only with basic control mCH2 – Position the Local/Remote selector (SLR) situated at the top middle of the electric board on LOCAL and switch on the power by turning the main switch (IG) to ON.
- Verify whether the phase sequence R-S-T is correct by checking the phase sequence relay situated in the middle of the electric control board is lit green: if this does not occur, disconnect the unit power supply from the external distribution panel and swap over two phases; then repeat the operation. **IN NO CASE SHOULD YOU TAMPER WITH THE WIRING DOWNSTREAM FROM THE MAIN SWITCH** since this may alter the correct sequence of other devices, e.g. pump(s).
- Put the compressor switch “QF” back on
- Close the electric control board and lock it by means of the ½- turn locks.

Starting up:

- Check that all external cocks of the water circuit are open and water flows properly (the flow alarm should not be triggered);
- Put the main switch on the ON position;
 - The (external) pump will start immediately;
 - After 60 seconds the compressor will start;

- Check the water thermal differential (12-7°C to be detected by means of a thermometer on the inlet and outlet water pipes of the unit);
- Check that there are no leaks on the refrigerant side and water side;
- Using all the screws supplied, close the unit.

Use:

- Always consult the USER manual and the µChiller or pCO1 manual provided with the unit when undertaking maintenance and/or advanced set-ups.

8.5 Start-up

Before starting the unit, turn the main switch on, select the operating mode desired from the control panel and press the “ON” button on the control panel.

The group will start if an enabling signal is received:

- linked to safety devices related to the water circulation pump(s);
- the flow switch (or differential pressure switch);
- by the T sensor measuring the temperature of the water returning from the system [chiller inlet];
- that there are no active alarms.

WARNING

If the unit fails to start up, check whether the service thermostat has been set at the rated calibration values.

ATTENTION

You should not disconnect the unit from the power supply during periods when it is idle but only when it is to be taken out of service for a prolonged period (e.g. at the end of the season).

8.6 Inspections during operation

- Check the phase sequence relay on the control board to verify whether the phases occur in the correct sequence: if they do not, disconnect the unit from power supply and invert two phases of the incoming three-pole cable. Never attempt to modify internal electrical connections: any undue modifications will render the warranty null and void.

- Check that the temperature of the water entering the evaporator is close to the value set on the service thermostat.

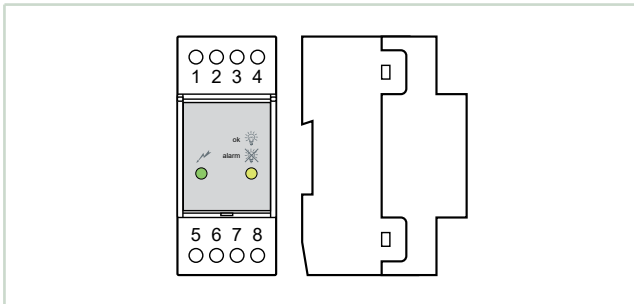

8.7 Refrigerant charge checks

After a few hours of operation, check whether the liquid level indicator has a green crown: a yellow colour indicates the presence of humidity in the circuit. In such a case the circuit must be dehumidified by qualified personnel.

Large quantities of bubbles should not appear through the liquid level indicator. A constant passage of numerous bubbles may indicate that the refrigerant level is low and needs to be topped up. The presence of a few bubbles is however allowed, especially in the case of high-glide ternary mixtures such as HFC R410A.

Also check that the end-of-evaporation temperature shown on the pressure gauge (refer to the pressure gauge scale for the refrigerant R410A) is about 4°C lower than the temperature of the water leaving the evaporator.

- Make sure the overheating of the cooling fluid is limited to between 5 and 8 °C. To this end:
 1. detect the temperature indicated by a contact thermometer placed on the compressor intake pipe;
 2. read the temperature indicated on the scale of a pressure gauge likewise connected to the intake side; refer to the pressure gauge scale for the refrigerant R410A.

The difference between the temperatures determined in this way indicates the overheating value.

- Make sure that the undercooling of the cooling fluid is limited to between 3 and 5°C. To this end:
 1. detect the temperature indicated by a contact thermometer placed on the compressor outlet pipe;
 2. read the temperature indicated on the scale of a pressure gauge connected to the liquid inlet at the condenser outlet; refer to the pressure gauge scale for the refrigerant R410A.

The difference between the temperatures determined in this way indicates the undercooling value.

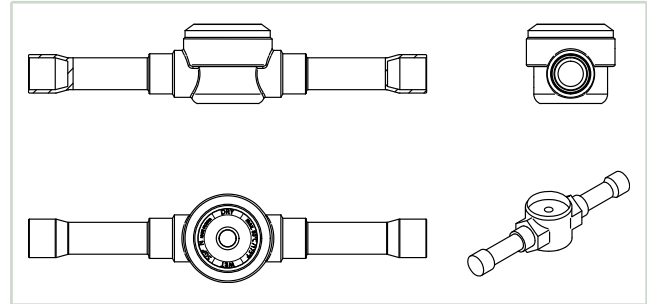

⚠ ATTENTION

All units of the ENW series are charged with R410A refrigerant except the versions with remote condenser which are charged with nitrogen. Any top-ups must be made using the same type of refrigerant. This operation is to be considered extraordinary maintenance work and must be performed by qualified personnel.

⚠ ATTENTION

The refrigerant R410A requires “POE” polyolester oil of the type and viscosity indicated on the compressor rating plate.

For no reason should oil of a different type be introduced into the oil circuit.

8.8 Group stop

The group is stopped by pressing the “OFF” key on the front panel or by acting on the main disconnector, or by acting on the special controls of the LCD user interface.

⚠ ATTENTION

It is recommended not to power off the unit via the mains power switch during regular shutdowns, but only in case of expected prolonged idle times (e.g. seasonal stops). The mains switch must be used to cut the unit off from the power supply when there is no current flow, i.e. when the unit is in the OFF state.

Additionally, by completely disconnecting voltage to the unit:

- any casing resistances would not be powered - which would damage the compressor upon its next start
- the only antifreeze protection would be the presence of glycol. If the unit is powered, the antifreeze protection is linked to the presence of the antifreeze option (if present).

⚠ ATTENTION

With the machine turned off but powered, the pumps could start automatically. Do not turn off any shut-off valves on the lines and do not carry out work on the lines before having disconnected all power supply to the machine.

When starting the machines (with a compressor) after a prolonged idle time without power supply, allow for at least 4-8 hours for heating of the enclosure via the provided heaters.

9 CONTROL AND SAFETY DEVICES

All control equipment is calibrated and tested at the factory before shipping the machine. However, after the unit has been operating for a reasonable period of time, it is advisable to check the operating and safety devices.

DANGER

All service operations on the control equipment must be carried out **EXCLUSIVELY BY QUALIFIED PERSONNEL**: incorrect calibration values can cause serious personal injuries and damage the unit.

Many of the operating and calibration parameters of control systems are set by microprocessor control and are password protected.

9.1 Control devices

9.1.1 Service thermostat

The service thermostat activates and deactivates the operation of the compressor, depending on chilled water (operation as a chiller) or heated water (operation as a heat pump) requirements, via a probe located at the inlet or outlet of the

» Setting operating parameters

Control device	Set point	Differential
Service thermostat [Cooling]	12 °C	2 °C
Service thermostat [H]	40 °C	2 °C

» Setting of safety-control devices

Control device	Start up	Differential	Re-activation
Antifreeze thermostat	+4 °C	2 °C	Automatic
Maximum pressure switch IV PED	45,0 bar	-	Manual
Max admissible PS switch IV PED	45,0 bar	-0 / +10%	-
Minimum pressure switch	1,5 bar	1,0 bar	Automatic
Modulating condensation control device [optional]	18 bar	10 bar	-
Time lapse between two starts of the same compressor	480 s	-	-
Flow switch alarm delay	20 s	-	-
Low pressure alarm delay	1 s	-	-

9.2 Safety devices

On each refrigerant circuit, according to the volumetric capacity of the installed compressors, the PED (Pressure Equipment Directive 2014/68/EU) category of the machine and the refrigerant circuit configuration, there are safety devices for the refrigeration circuit as prescribed by the PED regulation. In particular, this regulation requires designing to be carried out by referring to the technical standard that is closest to the type of item produced; in the case of machines designed for air conditioning or cooling of liquids, the UNI EN 378-2 standard is referred to.

water exchanger. This device is managed by the microprocessor control and operates with a proportional band of adjustable width. For further details please refer to the control manual.

9.1.2 Control device settings

All the control devices are set and tested in the factory before the unit is dispatched. However, after the unit has been in service for a reasonable period of time you can perform a check on the operating and safety devices. The setting values are shown in the following Tables.

ATTENTION

All servicing of the equipment is to be considered extraordinary maintenance and may be carried out **SOLELY BY QUALIFIED TECHNICIANS**: incorrect settings may cause serious damage to the unit and injury to persons.

WARNING

The operating parameters and control system settings configurable by means of the microprocessor control are password protected if they have a potential impact on the integrity of the unit.

According to this standard, on a case by case basis, on the high and low pressure sides of each refrigerant circuit safety venting valves can be provided, connected to an exchange tap, to protect the pressurised parts and programmed to be activated when the maximum pressure setting is reached on the corresponding side (PS).

The high and low pressure sides have a maximum pressure PS defined by the pressure limit of the machine components; this pressure cannot be reached during normal machine operation. For more details, refer to the refrigerant circuit diagram of the unit.

During normal use, high pressure at the compressor outlet is limited by the high pressure switch, set to the maximum working pressure of the compressor itself, which depends

on the unit model and is equal to the PS, in compliance with the UNI standard EN 378-2.

All the safety devices installed on the units are listed and described here below.

9.2.1 Maximum pressure switch

The high pressure switch stops the compressor when the delivery pressure exceeds the set value.

⚠ ATTENTION

Do not attempt to change the setting of the maximum pressure switch. Should the latter fail to trip in the event of a pressure increase, the pressure relief valve will open.

The high pressure switch must be manually reset; this is possible only when the pressure falls below the set differential (see Table Setting of safety-control devices).

9.2.2 Minimum pressure switch

The low pressure switch stops the compressor when the intake pressure falls below the set value for more than 120 seconds.

The switch is automatically reset when the pressure rises above the set differential (see Table Setting of safety-control devices).

9.2.3 Service thermostat

This device permits to enable and disable the compressors' operation as a function of the reading of the inlet water temperature of the chilling unit [return from the system]. For further details, refer to the microprocessor control manual.

9.2.4 Anti-freeze thermostat function

The antifreeze probe is located at the evaporator outlet and stops the compressor when the temperature goes below the set limit value. Together with the flow switch and low pressure switch, this device protects the evaporator from the risk of freezing as a result of faults in the water circuit.

For further details, refer to the microprocessor control manual.

9.2.5 Anti-recycle timer

The function of the timer is to prevent excessively frequent compressor starts and stops. This device imposes a minimum time lapse of 480 seconds between two compressor starts.

For further details, refer to the microprocessor control manual.

⚠ ATTENTION

Never attempt to change the delay set in the factory: wrong settings could cause serious damage to the unit.

9.2.6 Refrigerant sensors (if "A2L-ready" and "R454B" refrigerant options present)

When the unit is provided with A2L-ready or R454B refrigerant options, refrigerant sensors are installed in all compressor boxes and in all separated sections of the electrical box. The refrigerant sensor is composed by:

- A main and a remote control board

- One sensor cartridge for each control board (only for "R454B" refrigerant option)

Pay attention that in the "A2L-ready" configuration the refrigerant sensor cartridge is not present. For this reason, the unit can't be operated with R454B refrigerant charge. If needed to charge the unit with R454B refrigerant, please see chapter 11 Substitution of R410A with R454B refrigerant p. 41.

For the units provided with R454B refrigerant, the unit is equipped with sensor cartridges.

In addition to the gas sensor element and the measuring amplifier, the sensor cartridge also contains a processor for measured value processing. All data and measured values of the sensor element are stored in the processor fail-safe and are transmitted digitally via the digital interface to the control board.

The control board functions are communication and supply of the gas sensors.

In normal operating mode (measuring mode) there are no faults present, the gas concentration of the active sensors is continuously polled and checked for plausibility.

The device continuously monitors itself, the measurement signal, the alarm relay and the communication to the sensor head.

When the alarm evaluation is activated, the gas signal is checked with each measurement cycle, if \geq or \leq alarm threshold and if exceeding, the alarm LED and the alarm relay are triggered. If the value falls again below the alarm threshold minus the set hysteresis, the alarm is automatically cancelled.

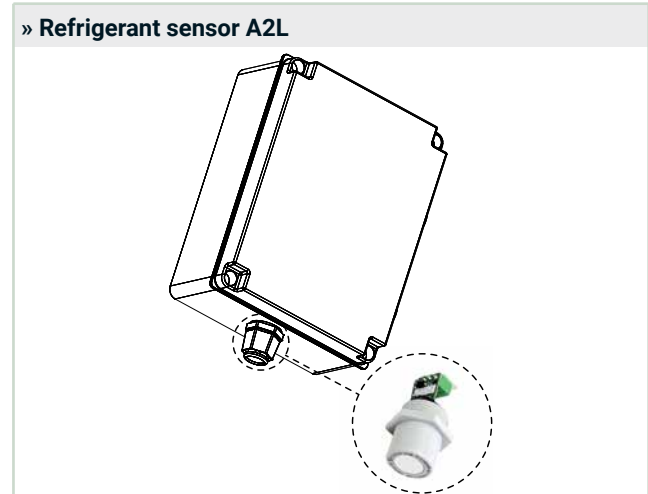

10 ROUTINE MAINTENANCE AND CHECKS

To keep the unit in good working order and guarantee the expected levels of performance and safety, it is necessary to carry out some periodic routine checks: some may be performed directly by the user while others must be carried out solely by specialised personnel.

In any case, the regulations in force in the country of installation must always be complied with.

10.1 Checks to be performed by the user

Operating these machine basically requires just switching on, switching off and seasonal switching between cooling and heating operation.

All other operations are maintenance tasks and must be performed by qualified personnel who are able to operate according to the laws and regulations in force.

ATTENTION

Pay special attention when working near the finned exchangers as the aluminium fins are very sharp.

10.2 Checks and maintenance to be performed by specialised personnel

The periodic inspections that must be performed by qualified and authorised personnel are indicated in the following chapter.

DANGER

- All the operations described in this section **MUST ALWAYS BE PERFORMED BY QUALIFIED PERSONNEL**.
- For safety reasons, adequate measures and precautions must be taken regarding installation, to prevent ambient temperature - when the machine is switched on or off - exceeding the provisions of paragraph 8.2 Operating limits p. 29.
- Before performing any work on the unit or accessing internal parts, be sure to have disconnected power supply.
- The compressor delivery pipe and upper part reach a maximum temperature of 110°C. Be very careful when operating nearby with the unit in operation.
- After maintenance operations, always close back the unit using the provided panels, fixing them with their tightening screws.
- For the safety of the maintenance staff in charge of the groups ENW, it is essential to switch off the unit from the main switch before carrying out maintenance operations.

To preserve the unit from possible faults and guarantee its correct operation over time, it is necessary to regularly carry out the inspections shown in the following table.

WARNING

The following table is for general guidance: please do not consider any operations involving components not present in a specific model.

This table shows the inspection schedule recommended by the manufacturer to ensure the expected performance and safety levels. For information on the inspection schedule and methods required at regulatory level, especially for the prevention of refrigerant leaks, the main European reference standards are EN-378 and the European F-Gas Regulation No. 517/2014. If there is a national regulation, reference should be made to it.

All the following procedures must be performed in compliance with the safety regulations described in this manual.

WARNING

In case of extraordinary maintenance (e.g. replacement of components) contact the technical department for the correct tightening torques. If the compressor is replaced, the filter must also be replaced.

ACTION		MAINTENANCE FREQUENCY			
		1 month	3 months	6 months	1 year
UNIT	Check that no unusual noise is emitted by the machine and in particular, that there are no vibrations and/or beating.			x	
CONTROL SYSTEM	Check the correct installation and the wiring conditions.	x			
	Check the operation of the LEDs of the display control system and of the alarms.		x		
	Check the connections for electrical and mechanical operation.			x	
	Check the functional elements (e.g. operating controls and display devices).			x	
	Check electrical/electronic and pneumatic input signals (e.g. sensors, remote controllers, control variables) to conform to normal values.			x	
	Check the values in the parameter list (see the Microprocessor Manual).				x
	Adjust the control function and control signals. Check the software cycle running (see the Microprocessor Manual).			x	
SWITCH BOOTH POWER SUPPLY CIRCUITS Caution: the electric cables and electrical components of the air conditioner are live.	Check the power supply in all phases.			x	
	Check the electrical connections and the mechanical function. Restore if not properly tightened.			x	
	Check the power supply of all the terminals.			x	
	Measure power consumption at all connected devices.			x	
	Check, adjust and tighten the functional elements (e.g. operating controls and display devices).			x	
	Check the safety equipment, e.g. thermal switch. Replace every 2 years.				x
	Check the protective covers.				x
	Check the tightening of the electrical terminals both inside the electrical panel and in the compressor terminal blocks. The mobile and fixed contacts of the contactors must be periodically cleaned and, if they show signs of deterioration, they must be replaced.				x
CONDENSATE/FREECOOLING COOLING WATER	Check the cooling water circuit, check for damage, leaks and ensure correct fixing.	x			
	Check the correct flow of water and clean the water filter.		x		
CONDENSATE/FREECOOLING COOLING WATER PUMP	Make sure the water pump works correctly.			x	
	Check the correct flow of water; clean the water filter.		x		
	Check for internal air: bleed air if present from closed circuits.		x		
	Check the safety equipment; water flow switch etc.			x	
	Check the percentage of glycol by comparing the minimum annual ambient temperature.			x	
	Check the pumps for excessive noise.				x
REFRIGERATION CIRCUIT Fluoride based refrigerants increase the greenhouse effect and are expected to conform to restrictions and regulations, according to national and European standards.	Measure the pressures and working temperatures (to be performed by a refrigeration technician).			x	
	Check the energy consumption, measure the heat temperature and check for unusual noise during operation.			x	
	Make sure there is no frost formation in the evaporator and in the compressor.		x		
	Check the operation of all the adjustment devices (power regulators, valves, etc.).	x			
	Check the efficiency of the actuators.				x
	Check the operation of the safety devices.			x	
	Check the refrigerant charge, the liquid level indicator and the operating parameters (undercooling, overheating, high and low pressure, degree of valve opening). If the amount of refrigerant is not sufficient, it must be restored by refilling with fresh refrigerant.			x	
	Check the oil level through the appropriate viewing windows.		x		
	Perform a test to check the oil internal humidity level.				x
	Check the enclosure heater operation.			x	
Check the humidity indicator on the liquid indicator (green = dry, yellow = wet); if the indicator is not green, as shown by the indicator sticker, replace the filter.			x		

ACTION		MAINTENANCE FREQUENCY			
		1 month	3 months	6 months	1 year
CHILLED WATER CIRCUIT	Check the filling of the hydraulic circuit, by venting it from the valves placed at the highest points.			x	
	Make sure that there are no water leaks.			x	
	Check for any air in the circuit: bleed air from the cooling water circuit using the special valve in the top part of the circuit.			x	
	Check that chilled water supply is guaranteed.			x	
	Check the water temperature and pressure at the inlet and outlet using thermometers and pressure gauges - if installed.			x	
	Check the correct operation of the 2- or 3-way valve.			x	
	Check the efficiency of the actuators.				x
	Make sure that the system is filled with the prescribed amount of glycol and that there is no ice in the hydraulic circuit.			x	
	In the event that there is a water leak and the circuit must be filled, make sure that the glycol concentration is correct.			x	
	Check that the water circulation is as required.			x	
	If the unit is expected not to be in operation for a long time, drain the water from the pipes and the machine, including the water exchanger if it is a Free-Cooling unit (if no glycol-based solutions are used). This operation is mandatory if ambient temperatures are expected to fall below the freezing point of the fluid used, during the unit down time.				
	Clean the external metal filters in the hydraulic lines.			x	
	Check the efficient operation of the flow switch or differential pressure switch.			x	
REFRIGERANT SENSORS (only if "A2L-ready" and "R454B" refrigerant options selected)	Check for maintenance.		x		
	Visual inspection of the device including cable for damage, vandalism etc.		x		
	Remove dust deposits etc. with a dry cloth, especially at the gas inlet.		x		
	Clean of the gas inlet filter.		x		
	Sensor cartridge replacement.				x

WARNING

Above a specific refrigerant charge, the installer is requested to prepare a system booklet which must be written and updated regularly for each maintenance operation, according to instructions provided by the applicable standards, including EN 378-2 and the European Regulation F-Gas n. 517/2014. In any case, the plant manager must comply with the regulations in force in the country of installation.

10.2.1 Inspection of the unit during service

EN 378-4: 2016 provides a number of indications concerning the checks to be performed on the unit during its working life.

This information is summarised in the standard in a table shown here below.

WARNING

The information regarding in-service inspection contained in the aforementioned standard can be used if there are no similar criteria in the applicable national legislation.

Subclause	Inspection		Test		
	External visual inspection according to Appendix G of EN 378-2:2016	Corrosion	System pressure test	Refrigerant leak detection system ^a	Safety devices inspection
D.2	X		X	X	
D.3	X		X	X	
D.4	X			X	
D.5				X	
D.6					X
D.7	X			X	
D.9		X ^b			

^a The system pressure must be higher than the atmospheric pressure for the leak test.

^b Not for new equipment.

— D.2 In-service inspection is performed after a maintenance service that could affect the resistance, or when a change in use has occurred, or when switching to a different refrigerant at higher pressure, or after the equipment has been idle for more than two years. Components that

are not compliant are changed. No test pressures higher than those suitable for the components' PS are applied.

— D.3 An in-service inspection is carried out after repairing or introducing significant

changes or expansions in systems or components. Tests should be limited to the parts concerned.

- D.4 An in-service inspection is performed after reinstallation on another site.
- D.5 The system leak test must be performed if leaks are strongly suspected. For the purposes of this paragraph, “inspected for leaking” means that the equipment or system is primarily tested for leaks using direct or indirect measurement methods, focusing on those parts of the equipment or system most likely to leak. The leak inspection frequency varies from:
 - every 12 months for systems with at least 3 kg of refrigerant, with the exception of hermetically sealed systems containing less than 6 kg;
 - every 6 months for applications containing at least 30 kg of refrigerant;
 - every 3 months for applications containing at least 300 kg of refrigerant.

Systems must be inspected to check for leaks in the month following the repairing of a leak, to ensure that the repair has been effective.

For applications containing at least 3 kg of refrigerant, the operator must keep track of the amount and type of refrigerant used, the top-up quantities added and the amount recovered during maintenance, service and final disposal.

For applications containing at least 300 kg of refrigerant, the operator must install leak detection systems. These systems should be inspected at least once every 12 months to ensure their proper operation.

Where an efficient leak detection system is provided on site, the inspection frequency may be halved.

High leak rates are not acceptable. Actions should be taken to eliminate any detected leak.

NOTE Fixed refrigerant detectors are not leak detectors because they cannot locate leaks.

- D.6 Safety devices are checked on-site: every year for safety switching devices (see EN 378-2: 2016 6.3.4.3.3), emergency signals and alarm systems; every five years for external pressure relief devices.
- D.7 Overpressure relief valves and break discs are visually inspected in accordance with EN 378-2: 2016, 6.3.4.3.1, 6.3.4.3.4 and 6.3.4.3.5 and annually tested for leaks.
- D.8 In the case of systems fully assembled and tested before their installation and systems built at the factory and transported as complete assemblies, or in two or more sections, the in-service inspection is performed after repairs have been carried out. If there are obvious refrigerant leaks, the entire system is leak tested.
- D.9 When pipes, piping supports, components and component supports are not insulated, they must be visually inspected. Pipes and insulated components must be visually inspected if the vapour barrier is damaged or if it does not work as intended.

This information must be supplemented with the provisions defined by the regulations on maintenance, including the European F-Gas Regulation No. 517/2014. In any case, the regulations in force in the country of installation must always be referred to.

10.2.2 Refrigeration circuit repairs

ATTENTION

Do not stand with sources of heat and open flames during the loading and unloading procedures of the machine.

During any repairs to the refrigeration circuit or compressor maintenance, minimise the opening time of the circuit. Even short exposure times of the ester oil to ambient air will cause the absorption of large amounts of moisture by the oil with the resulting formation of weak acids.

If the refrigeration circuit has been repaired, the following operations must be carried out:

- leak test;
- refrigeration circuit vacuum and drying cycle;
- refrigerant charge

WARNING

If the system needs to be drained, always collect all the refrigerant present in the circuit using suitable equipment, by working exclusively in the liquid phase.

10.2.2.1 Leak test

As far as leak tests are concerned, the units will leave the factory after having been tested according to the procedures indicated in EN 378-2.

A leak test on the installation site is necessary whenever the refrigeration circuit has been repaired or if the cooling connection between modules of a split unit must be carried out.

ATTENTION

Leak tests on site must be carried out by specialised and authorised personnel, who must operate according to the methods indicated in EN 378-2, if applicable in the country of installation, or according to local regulations in force.

10.2.2.2 High vacuum and refrigeration circuit drying

To obtain high vacuum in the refrigerant circuit, it is necessary to have a pump capable of generating a high degree of vacuum, at least 15 Pa of absolute pressure, with a capacity of 10 m³/h. If this pump is available, normally one draining only should be controlled to reach the absolute pressure of 15 Pa.

When a suitable vacuum pump is not available or when the circuit has been open for long periods of time, it is strongly recommended to follow the triple draining method. This method is also indicated when there is moisture in the circuit.

The vacuum pump must be connected to the charging points. The required procedure is as follows:

- Drain the circuit to an at least 35 Pa absolute pressure: at this point, introduce nitrogen in the circuit up to a pressure of about 1 bar.
- Repeat the operation described in the point here above.
- Repeat the operation described in the point here above for the third time, now trying to achieve the hardest possible vacuum condition.

With this procedure it is possible to easily remove up to 99% of the pollutants.

10.2.2.3 Refrigerant charge

DANGER

Before carrying out any operation with the refrigerant, it is recommended to read the special safety data sheet (MSDS). The refrigerants used in the entire Eneren product range are R410A R454B.

These have the following characteristics:

- **TOXICITY**, the refrigerants mentioned above all belong to group A according to the standard 34 ASHRAE; this group includes all refrigerants that are found not toxic for concentrations equal to or lower than 400 ppm.
- **FLAMMABILITY**, according to the standard 34 ASHRAE, refrigerant R-410A is classified in the safety group A1, i.e. non-flammable at a pressure of 1 atm (101.3 kPa) and 18°C. R-454B is classified in the A2L safety group, i.e. mildly flammable at 1 atm pressure (101.3 kPa) and 18°C.
- **CATEGORY**, the refrigerants used are fluids of category II according to the PED 2014/68/EU directive and therefore, they are not dangerous.

The area must be immediately evacuated if there is a constant leak of refrigerant gas. The gases concentrate near the floor, thereby restricting the availability of oxygen. Once evacuated, the area must be ventilated with fans or blowers in order to circulate the air at floor level.

For loading operations, follow the procedure described below:

- connect the refrigerant gas cylinder to the 1/4 SAE male filler outlet located on the liquid line, making sure that there are no impurities, moisture and/or incondensable gases in the inlet pipes;
- load liquid state charge until 75% of the total charge has been introduced;
- then connect to the intake on the suction line and complete liquid charge loading until no more bubbles appear on the liquid viewer and the operating values are reached that are indicated in the paragraph 8.7 Refrigerant charge checks p. 32.

ATTENTION

A unit originally filled at the factory with a refrigerant type cannot be filled with different refrigerants without a written permission from manufacturer.

If the (mildly flammable) R454B is used, it is recommended to provide all the safety devices required by law during installation. In case of indoor installation, contact the manufacturer

Refer to paragraph 13.2 Environment protection p. 44 contained in this document.

10.2.3 Refrigerant sensors (only if A2L-ready and R454B refrigerant options selected)

It is obligatory to perform maintenance regularly in order to maintain safety, measuring and warning functions of the device. The maintenance includes visual, functional and system inspections and must only be carried out by appropriately qualified personnel.

When carrying out maintenance and repair work according to the user manual, only use original spare parts from MSR-Electronic. Repairs or changes of the warning devices

not complying with the maintenance manual or carried out by unauthorized persons can affect proper equipment and safety features and always result in a termination of the manufacturer's warranty and certificates.

For scheduled maintenance of the sensor by qualified technicians, please contact Technical Support Eneren.

According to EN 45544-4, inspection and service has to be executed at regular intervals. The maximum intervals have to be determined and observed by the person responsible for the gas warning system according to the legal requirements. It is recommended to apply the inspection and maintenance intervals as prescribed in the general regulations of the gas measuring technique like EN50545, VDI-2053, EN 60079-29-1 etc. The inspection interval normally is three months.

During inspection it has to be checked in particular:

- Maintenance / calibration interval not exceeded;
- Visual inspection of the device including cable for damage, vandalism etc;
- Remove dust deposits etc. with a dry cloth, especially at the gas inlet;
- The filter at the gas inlet has to be replaced if extremely dirty.

When the calibration period exceeds, it is recommended to contact Eneren Technical Support to have a new sensor cartridge.

ATTENTION

The refrigerant leak sensor alarm may also be triggered by an open control panel door or a clogged panel fan filter.

10.2.3.1 Change of sensor cartridge SC2 on sensor board MSR WSB2 (only if R454B refrigerant option selected)

Products involved

1. SENSOR BOARD WSB2, Code – HF11000741 SENSORE GAS MSR;
2. SCHEDA BASE WSB2 REMOT CARD Code – HF11000742 SENSORE GAS MSR;
3. SCHEDA REMOTA RB2 SENSOR CARTRIDGE SC2, following Codes for different refrigerants:
 - A. SENSORE GAS MSR, CARTUCCIA R1234ZE – HF11000743;
 - B. SENSORE GAS MSR, CARTUCCIA R410A – HF11000988;
 - C. SENSORE GAS MSR, CARTUCCIA R452B – HF11000951;
 - D. SENSORE GAS MSR, CARTUCCIA R513A – HF11000786;
 - E. SENSORE GAS MSR, CARTUCCIA R454B – HF11000950

General information

ATTENTION

The cartridge must be replaced every 12 months. After 12 months the alarm 231 is generated (displayed on the microcontroller) and the machine is stopped.

To view the total operating hours of the sensor, access the "info" menu of the microcontroller. As the sensor will need to be replaced after 8640 hours, make sure that service by a qualified technician is scheduled in good time.

Sensor cartridge replacement

The sensor cartridge (SC) can be easily and conveniently replaced with a new one.

The local bus communication (Sensor Cartridge <> BSB) is constantly monitored during operation and immediately

generates an error message on the gas controller in case of failure or interruption. When replacing the sensor unit, local bus communication is also interrupted and this produces an error message.

The local bus communication is automatically established and tested. At the same time the gas type and the measuring range of the "new" SC are compared with the data stored in the BSB. If they match and the communication is correct, the error message will be automatically acknowledged at the Gas Controller.

After replacing the sensor, the counter must be reset from the microcontroller display:

» A2L sensor maintenance display

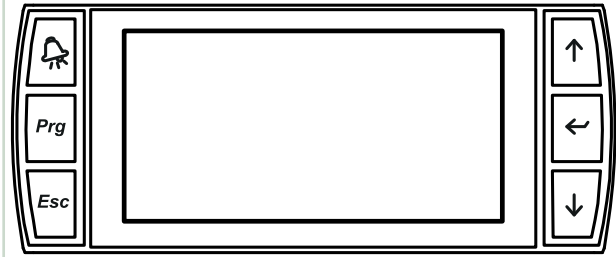

ATTENTION

For others useful information please read supplier manuals

» Exchange of sensor cartridge

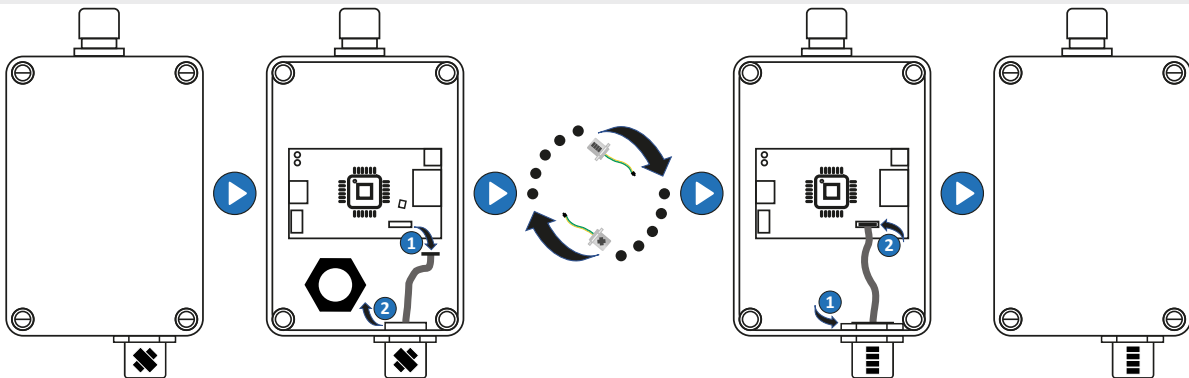

- Disconnect the SC connector from the BSB or the RSB (error message will be activated);
- Loosen the locknut;
- Remove used SC;

- Take calibrated SC out of the original packaging, check for gas type, measuring range and valid calibration date;
- Insert the SC and retighten with lock nut;
- Insert the SC plug into the socket at the BSB or RSB. Check plug for proper engagement.

10.3 Components description

For a clear representation of the components that make up the unit, please refer to the wiring diagram supplied with the unit.

11 SUBSTITUTION OF R410A WITH R454B REFRIGERANT

In the units provided with A2L-ready option, it is possible to substitute the R410A refrigerant with the new generation refrigerant R454B.

All the actions connected to the refrigerant substitution must be performed by authorized technicians, who will:

- certify the correct execution of the charging process;
- check for the correct start-up and operation of the refrigerant sensors;
- provide a new silver label to replace the old one.

Please contact Support Team to organize the substitution process.

12 TROUBLESHOOTING

For troubleshooting purposes, please refer to the list and to the complete description of the alarms related to the installed software version.

This document can be downloaded from the portal <https://obdoc.gallettigroup.com> after user registration.



WARNING

Do not reset the alarm until after an accurate analysis and subsequent removal of the causes of the alarm: continuous resetting operations could lead to compressor breakdowns.

DANGER

As far as possible remedies are concerned, it is first of all essential to have read the chapter “4 Safety prescriptions p. 11”, to be able to adopt all the necessary precautions.

You should be extremely careful when attempting to implement any of the possible remedies suggested: overconfidence can result in injuries, even serious ones, to inexperienced individuals.

In case of breakdowns, please contact a qualified and authorised technician or our customer care.

» Troubleshooting

Fault	Possible causes	Corrective action
The unit does not start	No electrical power supply.	Check its presence both on the primary and auxiliary circuit.
	The circuit board is not powered.	Check the fuses.
	There are alarms present.	Check the microprocessor panel for the presence of alarms, eliminate their cause and restart the unit.
	The phase sequence is wrong.	Invert two phases in the primary power line after disconnecting them upstream from the unit.
The compressor is noisy	The compressor is rotating in the wrong direction.	Check the phase sequence relay. Invert the phases on the terminal board after disconnecting the unit and contact the manufacturer.
Faulty high pressure	Insufficient flow of air to the condenser.	Check that all fans turn correctly.
		Check the compressor inlet air T and avoid any situations of backflow.
		Check that the effective voltage RMS to the fans is the maximum. Check the pilot pressure transducers of the rev. regulator [optional].
	Make sure the finned coils are clean.	
Presence of air in the refrigerant circuit, as revealed by the presence of bubbles in the flow indicator also with undercooling values exceeding 5°C.	Drain and pressurise the circuit and check for leaks. Evacuate slowly [for more than 3 hours] until reaching a pressure of 15 Pa and then recharge in the liquid phase.	
Unit overcharged. As revealed by an undercooling of more than 8°C.	Drain the circuit.	
Clogged thermostatic valve and /or filter. Such faults may occur in the presence of low pressure.	Check the temperatures upstream and downstream from the valve and filter and replace them if necessary.	
Low condensation pressure	Faulty transducers.	Check the transducers and the correct operating of the depressor on the Schrader valves to which they are connected.
	Too low external T and/or in the presence of strong winds.	Install the condensation control device and/or protect the unit from the prevailing winds.
Low evaporation pressure	Malfunctioning of thermostatic valve.	Warming the bulb with your hand, check whether the valve opens and adjust it if necessary. If it does not respond, replace it.
	Filter clogged.	Pressure drops upstream and downstream from the filter should not exceed 2°C. If they do, replace the filter.
	Low condensing temperatures	Check the efficiency of the condensation control device [where present].
	Low level of refrigerant	Check the refrigerant level by measuring the degree of undercooling; if it is below 2°C replenish the charge.
	Coil frosted if heat pump is operating.	Check the correct defrost parameter settings. Make sure the 4-way valve works properly.
	Low external T if heat pump is operating.	Check compliance with the operating limits and eliminate any bypasses and back flow of air.
The compressor does not start	The thermal protection device has tripped.	Check the status of the thermal contact in models equipped with protection modules. Identify the causes after restarting.
	Tripping of circuit breakers or fuses in line after short circuit.	Check the cause by measuring the resistance of the individual coils and the isolation towards the chassis before re-connecting the power.
	Activation of one of the high or low pressure switches.	Check on the microprocessor, eliminate the causes.
	The phases in the distribution cabin have been inverted.	Check the phase sequence relay.

Defrosting absent or incomplete (H versions)	Error in parameter settings.	Check the setting of the start and end defrost parameters on the microprocessor.
		Check whether defrosting water is properly drained from the coils.
		Check the homogeneous distribution of the refrigerant temperatures throughout the height of the coil: the maximum allowed delta is 10°C. Check the machine charge.
	Poor efficiency of the 4-way valve.	Check that it is energised and de-energised regularly.
Free Cooling malfunction (F versions)	Poor efficiency of the 3-way valve.	It is possible to manually force the valve to open, but it is advisable to leave the unit in mechanical operation only.
	Poor efficiency of the 3-way valve.	È necessario forzare manualmente in chiusura la valvola, sostituendone quanto prima il servomotore.

13 RETIRING THE UNIT

When the unit has reached the end of its expected working life and therefore needs to be removed and replaced, a number of precautions must be followed:

- the refrigerant gas that it contains should be recovered by specialised personnel and sent to a waste collection facility;
- the lubrication oil of the compressors must also be recovered and sent to special collection centres;
- the structure and the various components, if not reusable, must be demolished and separated according to their product type: this is particularly relevant for copper and aluminium, which are present in fairly high amounts in the machine.

This should be done to facilitate work at the special collection, disposal and recycling centres and to minimise the environmental impact that this operation requires.

ATTENTION

If the unit, or part of it, has been decommissioned, any of its parts that are likely to cause dangers must be rendered harmless.

Please note that any replacement of unit parts subject to separate waste disposal must always be done by referring to the currently applicable legal provisions.

Please note that it is mandatory to record the loading and unloading of special and toxic-harmful waste.

Collection of special and toxic-harmful waste must be carried out by specially authorized companies.

Disposal of special and toxic or harmful waste must be carried out in compliance with the law provisions in force in the user's country.

For unit scrapping, follow the law prescriptions in force in the user's country. Before demolition ask the appointed organism to inspect the unit and write a report.

Finally, carry out scrapping according to the law in force in the country of use.

WARNING

Dismantling, disposal and scrapping operations must be carried out by qualified personnel.

13.1 Waste electrical and electronic equipment management

This product falls within the application scope of the Directive 2012/19/EU concerning the management of waste electrical and electronic equipment (WEEE).

Equipment must not be disposed of with household waste as it is made of different materials that can be recycled at special facilities. Please inquire through your municipal authorities as to the location of the eco-friendly waste management sites where waste can be received for disposal and its subsequent recycling as recommended.

Furthermore, please note that, when an equivalent appliance is purchased, the seller is expected to collect free of charge the old product to be disposed of.

The product is not potentially dangerous for human health and the environment, as it does not contain any harmful substances according to the Directive 2011/65/EU (RoHS), but if disposed of freely in the environment, it might adversely affect the ecosystem.

Read the instructions carefully before using the equipment for the first time. It is strongly recommended not to use the product for any purpose other than that for which it was designed, to prevent the risk electric shock if the product is used incorrectly.

WARNING

The crossed-out wheellie bin symbol on the equipment label indicates that the equipment is compliant with the Waste Electrical and Electronic Equipment (WEEE) Directive.

Disposing of the equipment freely in the environment or illegally disposing of the equipment are punishable by law.

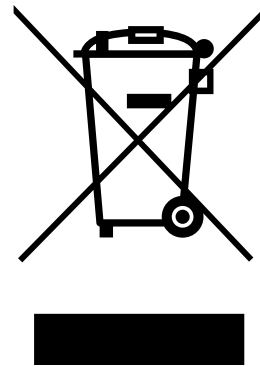

13.2 Environment protection

In general, the laws regulating the use of substances that damage the stratospheric ozone layer and the gases responsible for the greenhouse effect in force in the various countries provide that it is forbidden to disperse refrigerant gases in the environment and request their originators to recover them and return them, at the end of their service life, to the retailers or to special collection centres.

The HFC R410A and R454B refrigerant, although not harmful to the ozone layer, is listed among the substances responsible for the greenhouse effect and must therefore be used in compliance with the above obligations.

ATTENTION

Caution is therefore recommended during maintenance operations in order to minimise refrigerant leaks as much as possible. In any case, refer to the laws in force in the country of installation.

13.3 Packaging disposal

The QR Code below is shown on a label on the packaging of the machine, which allows the user to identify the nature of the packaging used in order to follow the correct disposal procedure.



⚠ ATTENTION

For disposal of packaging, always refer to local laws that implement Directives 2018/851/UE and 2018/852/UE.

14 SAFETY DATA SHEET OF REFRIGERANT

For refrigerant fluid safety data sheet, please refer to the documents supplied with the unit.



Viale Spagna, 31/33 - 35020 Tribano (Padova) - Italy
Ph. +39 049 9588511 - Fax: +39 049 9588522 - info@eneren.it
www.eneren.it