

USER MANUAL

ELA

MULTIFUNCTION HEATPUMP FOR 2 AND 4-PIPE SYSTEMS
AIR-WATER UNIT
FOR CONTEMPORARY HEATING AND COOLING

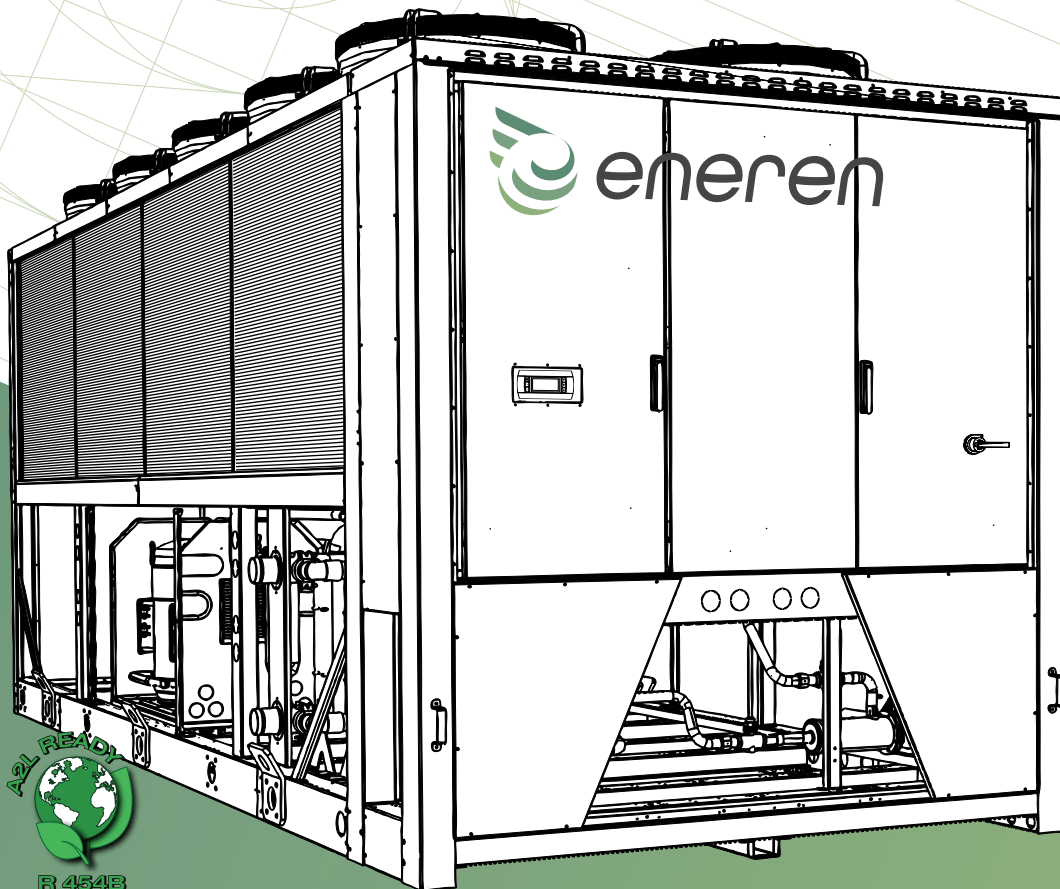

EN
TRANSLATION OF THE ORIGINAL INSTRUCTIONS

HF61GJ0745A / 05_23

INTRODUCTION

ELA

 **WARNING**

CAREFULLY READ THIS MANUAL BEFORE USING THE UNIT.

 **DECLARATION OF CONFORMITY**

The declaration of conformity is attached separately to the documents on board the unit, usually placed inside the electrical compartment.

Dear Customer,

Thanking you for choosing our products, we are pleased to provide you this manual for the correct use of equipment.

Please read the recommendations described in the following pages carefully and keep the manual available to personnel who will be responsible for managing and maintaining the unit.

Our company is at your complete disposal for any and all questions that you should require both in the unit starting phase and at any time of its utilization.

Should scheduled and unscheduled maintenance be necessary, please contact our After-sales Technical Service for assistance and spare parts.

Please find here attached our direct contacts in case you may need assistance:



ENEREN S.r.l.
Viale Spagna, 31/33
35020 Tribano (Pd) ITALY
Tel + 39 049 9271513
Fax + 39 049 9588522
e-mail : info@eneren.it



049-9271513



support@eneren.it

START-UP INSTRUCTIONS

1 YOUR INSTALLATION

All the tips required for a perfect installation of the equipment can be found in the installation manual.
It is important to place a net filter at all water circuit inlets.

The filter must be made of stainless steel with a mesh that does not exceed 1 mm.

2 REQUIRED ACCESSORIES FOR A PROPER INSTALLATION OF THE UNIT

For the proper operation of the unit and for the validity of the warranty, the installation of the following hydraulic components will be necessary:

- Y-strainers in the inlet pipes to the unit;
- anti-vibration couplings in each pipe connected to the unit;
- appropriately dimensioned safety valves on each circuit of the system;
- appropriately dimensioned expansion vessels on each circuit of the system.

3 FIRST START-UP

With at least 15 working days in advance, send the machine start request via email or fax to the following contact ENEREN:

Fax. 049 9588522

e-mail: support@eneren.it

Tel. 049 9271513

ENEREN Assistance will organize the intervention by putting you in contact with Authorized Technical Assistance Center of the area.

All the preliminary checks and testing of the machine will be carried out together with your staff.

Your staff will be given instructions for the correct running of the machine.

4 WARRANTY ISSUE

For the warranty to be valid, the first start-up by an Authorized Technical Assistance Center is mandatory.
After testing, the Authorized Technical Assistance Center will issue a valid test certificate for the machine warranty.

Each unit has an identification plate that is located on its frame and inside the electrical control panel, which shows all the data necessary for the installation, maintenance and traceability of the machine.



THE LABEL SHOWS THE FOLLOWING DATA:

- Manufacturer/Marketing body
- CE mark, possibly accompanied by a subscript that identifies the certifying body for the Pressure Equipment Directive 2014/68/EU (PED). The number of the certifying body must be indicated for units of a PED category equal to or greater than class 2.
- Series and size of the unit
- Date of manufacture
- Main technical data

Note the model, the serial number, the final refrigerant charge and the machine reference diagrams attached to this manual so that they can be easily found in case of data plate damaging and system maintenance.

ATTENTION

Never remove the label. This shows the serial number of the unit from which it is possible to obtain information about the technical features and the components installed, to then identify the unit correctly.

WARNING

The data contained in this manual are subject to change without notice

Modello - Model	
Matricola - Serial number	
Codice identificativo - ID code	
Data di produzione - Date of production	
Categoria PED/ 2014/68/EU - Category PED/ 2014/68/EU	
Procedura di valutazione conformità PED - PED conformity module	
Max pressione ammissibile (PS) lato alta pressione - Max allowable pressure (PS) high pressure side [bar-r]	
Max pressione esercizio (PS) lato bassa pressione - Max allowable pressure (PS) low pressure side [bar-r]	
Max/min temperatura di stoccaggio - Max/min storage temperature [°C]	
Max/min temperatura ambiente di funzionamento - Max/min ambient working temperature [°C]	
Potenza frigorifera* - Cooling capacity* [kW]	
EER*	
Potenza termica* - Heating capacity* [kW]	
COP*	
Refrigerante - Refrigerant [Ashrae 15/1992] / GWP	
Carica refrigerante - Refrigerant charge [kg]	C1 C2 C3 C4
Refrigerante aggiunto - Added refrigerant [kg]	C1 C2 C3 C4
Carica totale refrigerante - Total charge refrigerant [kg]	
CO2 equivalenti - CO2 equivalent [t]	
Taratura pressione lato alta - High pressure switch set [bar-r]	
Taratura pressione lato bassa - Low pressure switch set [bar-r]	
Taratura valvola sicurezza refrigerante lato alta/bassa pressione - Safety valve refrigerant high/low pressure side set [bar-r]	
Massima pressione esercizio circuito acqua - Max working pressure water circuit [bar-r]	
Taratura valvola sicurezza acqua - Safety valve water side set [bar-r]	
Alimentazione elettrica - Power supply	
Potenza massima assorbita - Max absorbed power [kW]	
Corrente massima - Full load ampere FLA [A]	
Corrente di spunto - Starting current LRA [A]	
Schema elettrico - Wiring diagram	
Schema frigorifero - Refrigeration diagram	
Peso a vuoto - Empty weight [kg]	
* EN14511-2	
Contiene gas fluorurati ad effetto serra disciplinati dal protocollo di Kyoto/ Contains fluorinated greenhouse gases governed by the Kyoto protocol Ermeticamente sigillato/Hermetically sealed	

SAFETY SYMBOLS	
WARNING	With reference to additions or recommendations for the correct use of the unit.
DANGER	With reference to dangerous situations that may occur with the use of the unit to guarantee personal safety.
ATTENTION	With reference to dangerous situations that may occur with the use of the unit to prevent damage to property and to the unit itself.

GENERAL CAUTIONARY NOTES

The operating rules contained in this manual are an integral part of the unit supply and are valid exclusively for the units covered by this manual. They contain all the useful and necessary information for safe operation and ideal, recommended use of the unit. The declaration of conformity is attached individually to the literature kept on the machine, usually inside the control cabinet.

Please follow the instructions given below:

- Read carefully the instruction manual which should be considered an integral part of the unit.
- Every operator and the personnel in charge of unit maintenance must read the manual throughout carefully and observe its prescriptions.
- The employer is requested to make sure that the operator has the necessary aptitude requirements for operating the unit and has carefully read the manual.
- The instruction manual must be easily available to the operation and maintenance personnel.
- Keep the manual for the entire working life of the unit.
- Make sure any updates that are received are integrated into the text.
- Hand over the manual to any other user or subsequent owner.
- Use the manual so that the contents are not damaged - entirely or in part.
- Do not remove, tear off or rewrite parts of the manual for any reason.
- Keep the manual with care; it must be available at the unit, stored in a special container, to protect it from moisture and heat, until final scrapping of the machine. The location where the manual is kept must be known to the user of the unit, to the managers, to the persons in charge of transportation, installation, use, maintenance, repairs, and end-of-life dismantling and scrapping. If the manual is lost or partially damaged, so that it is no longer possible to read all of its contents, it is advisable to request a new one from the manufacturer.
- Avoid hasty and incomplete preparation that lead to improvisation and cause many accidents.

Pay close attention to the safety symbols shown in the table on the previous page and to their meaning.

Before starting to work, read through and strictly observe the following suggestions:

- the operator must always have the instruction manual readily available at any time;
- plan each action carefully;
- before beginning to work, make sure that the safety devices work properly and you have no doubts about their operation; otherwise, do not under any circumstances start the unit;
- carefully observe the warnings relating to special hazards contained in this manual;
- preventive and thorough maintenance guarantees constantly high operating safety for the unit. Never delay repairs and always have them carried out solely by qualified personnel; only original spare parts are to be used.

THE MANUFACTURER shall not be liable for any accident to persons or property which may occur due to:

- failure to comply with the instructions in this manual regarding the operation, use and maintenance of the unit;
- violent actions or incorrect manoeuvres when performing maintenance on the unit;
- alterations made to the unit without prior written authorisation from the MANUFACTURER;
- events that are, in any case, unrelated to the normal and correct use of the unit;
- in any case, if the user attributes the incident to a defect in the unit, he must prove that the damage caused was a main and direct consequence of this "defect".

This manual reflects the state of the art at the time of unit sale: The MANUFACTURER reserves the right to update its products and manuals without any obligation to update earlier products and manuals, except in special circumstances. These may not be considered inadequate only because they have been subsequently updated based on new experience.

ATTENTION

- The installer must provide adequate documentation that must comply with EN 378-3 if applicable in the country of installation; otherwise, reference should be made to the local regulations in force.
- When installing or servicing the unit, the rules stipulated in this manual must be complied with together with those on board the unit and in any case all necessary precautions must be taken.
- The fluids under pressure in the cooling circuit and the presence of electrical components may cause hazardous situations during installation and maintenance work.
- Any action on the unit must be carried out by qualified and authorised personnel. In the event of a fault, do not attempt repairs on your own and do not let unauthorised technicians carry out repairs, or the guarantee will no longer be valid.
- The initial start-up must be carried out exclusively by qualified personnel authorised by the marketing entity (see annex).
- Before performing any work on the unit, ensure it has been disconnected from the power supply.
- For maintenance service or repairs always and exclusively use original spare parts. THE MANUFACTURER declines all responsibility for damages that may occur due to non-compliance with the above.
- The unit is guaranteed according to the contractual agreements entered into upon its sale: however, failure to comply with the rules and instructions contained in this manual and any modification in the unit not previously authorised, will cause an immediate loss of guarantee validity.
- This manual describes the intended use of the unit and provides instructions for its handling, installation, assembly, adjustment and use. It supplies information on the maintenance schedule, how to order spare parts, the presence of residual risks, and staff training. Therefore, before handling, installing, using or carrying out any maintenance on the unit, read the manual very carefully.
- It is important to remember that the use and maintenance manual can never replace adequate user experience. This manual represents a reminder of the main operations to be performed by operators who have received specific training, for example by attending training courses held by the manufacturer, with reference to particular maintenance operations.
- Make sure all the users have thoroughly understood the operating instructions together with the meaning of any symbols on the unit.
- Possible accidents can be avoided by following these technical instructions drafted in accordance with the Machinery Directive 2006/42/EC and subsequent additions.
- In any case, always comply with national safety regulations.
- Do not remove or damage guards, decals, stickers and wording, especially any that are required by law.
- Adhesive labels intended for safer use are applied to the unit, therefore, it is very important to replace them if they become illegible.

WARNING

- The electrical wiring, hydraulic and refrigeration diagrams and the technical data shown in this manual are supplied for guidance only and may be changed without prior notice for the purpose of improving the product range. For detailed information on specific models, refer to the specific documentation attached to the each product.

Any updates or additions to this use and maintenance manual are to be considered an integral part of the manual and may be requested via the contact phone numbers listed in this manual. Contact the MANUFACTURER for additional information and to share any feedback and recommendations aimed at improving the manual.

If the unit is transferred to a new owner, the MANUFACTURER expects you to please notify the address where to send any manual additions for the new user.

TABLE OF CONTENTS

1	INTRODUCTION	p. 3	10	ROUTINE MAINTENANCE AND CHECKS ..	p. 40
2	START-UP INSTRUCTIONS	p. 4	10.1	CHECKS TO BE PERFORMED BY THE USER p. 40
3	SERIES	p. 8	10.2	CHECKS AND MAINTENANCE TO BE PERFORMED BY SPECIALISED PERSONNEL p. 40
3.1	SCOPE OF APPLICATION	p. 8	10.3	COMPONENTS DESCRIPTION p. 45
3.2	PRODUCT INFORMATION	p. 8	11	SUBSTITUTION OF R410A WITH R454B REFRIGERANT	p. 46
3.3	MODELS AND VERSIONS	p. 9	12	TROUBLESHOOTING	p. 47
3.4	MAIN TECHNICAL SPECIFICATIONS	p. 10	13	RETIRING THE UNIT	p. 49
4	SAFETY PRESCRIPTIONS	p. 11	13.1	WASTE ELECTRICAL AND ELECTRONIC EQUIPMENT MANAGEMENT p. 49
4.1	GENERAL SAFETY RULES	p. 11	13.2	ENVIRONMENT PROTECTION p. 49
4.2	GENERAL PRECAUTIONS	p. 11	13.3	PACKAGING DISPOSAL p. 50
4.3	LOCATION OF SAFETY DATA PLATES	p. 14	14	SAFETY DATA SHEET OF REFRIGERANT	p. 51
4.4	MAINTENANCE PRECAUTIONS	p. 15			
4.5	PRECAUTIONS IN CASE OF REFRIGERANT LEAKAGE	p. 15			
5	TRANSPORT, INSPECTION, HANDLING, DIMENSIONS AND POSITIONING OF THE UNIT	p. 17			
5.1	TRANSPORT	p. 17			
5.2	INSPECTION	p. 17			
5.3	CONVEYANCE	p. 17			
5.4	UNPACKING	p. 19			
5.5	SITING AND DAMPERS	p. 20			
5.6	INSTALLATION CLEARANCE REQUIREMENTS	p. 23			
6	PLUMBING AND ELECTRICAL CONNECTIONS	p. 25			
6.1	HYDRAULIC CONNECTIONS	p. 25			
6.2	TANK FILLING MODE	p. 28			
6.3	ELECTRICAL CONNECTIONS	p. 28			
6.4	ELECTRICAL DATA	p. 29			
6.5	HYDRAULIC AND REFRIGERATION DIAGRAMS	p. 29			
7	MICROPROCESSOR CONTROL	p. 30			
8	START-UP	p. 31			
8.1	PRELIMINARY CHECKS	p. 31			
8.2	OPERATING LIMITS	p. 31			
8.3	THERMAL CARRYING FLUID	p. 34			
8.4	START-UP	p. 34			
8.5	INSPECTIONS DURING OPERATION	p. 35			
8.6	REFRIGERANT CHARGE CHECKS	p. 35			
8.7	GROUP STOP	p. 35			
9	CONTROL AND SAFETY DEVICES	p. 37			
9.1	CONTROL DEVICES	p. 37			
9.2	SAFETY DEVICES	p. 37			

3 SERIES

3.1 Scope of application

The Multi-purpose class A heat pumps air condensed with scroll compressors of the ELA series have been designed for cooling or heating water and glycol solutions in applications suitable for civil, industrial and technological conditioning.

WARNING

Regarding the unit setting and its use, it is important to know that:

- all models of the series ELA are designed and built for outdoor installations: avoid covering with canopies or positioning close to trees (even if only partially covering the unit) - which might obstruct regular ventilation of the unit external finned heat exchanger;
- the units are designed and built to operate in the temperature ranges indicated in paragraph 8.2 Operating limits p. 31: applications outside the indicated limits may be authorised by the MANUFACTURER, subject to verification and subsequent written authorisation. The air-water units are equipped with electric resistors, on request, for heating the plate heat exchanger, should the unit be exposed to cold temperatures during the winter shutdown period. This resistor is activated when the water temperature at the exchanger outlet falls below the anti-freezing probe calibration temperature;
- the storage temperature of the unit must be within the limits indicated in the paragraph 8.2 Operating limits p. 31;
- **the units are designed to operate in a closed hydraulic circuit.** In the case of open tanks, it is advisable to contact the design department which will indicate the best solution to adopt, such as uncoupling the exchanger;
- ventilation of the unit external finned heat exchanger and the clearance space around it must be guaranteed;
- avoid positioning the unit in such a way that the prevailing winds cause the recirculation of air to the external exchangers; a speed of 8 m/s (28.8 km/h) is enough to produce a sufficient stagnation pressure to guarantee about 60% of the rated airflow. [For situations where the wind action is unavoidable and there is a simultaneous presence of temperatures below -5°C, condensation control for low outdoor temperatures must necessarily be of the condenser exchanger flooding or throttling type. Please contact the manufacturer's design department for details];
- be aware that in certain environments there could be sound wave reverberation;
- the installation environment must be immediately suitable from first positioning of the unit and not just after installation completion (for example, do not install and operate the unit in premises and open work sites where completion works might damage the unit);
- the unit must only be used for housing, industrial and technological conditioning; any other use is considered not recommended.
- failure to comply with the aforementioned items and those contained in the manual will cause an immediate

loss of guarantee validity; in this case, the manufacturer declines all responsibility for any damage to persons, property or the unit that may derive from it.

DANGER

- Install the unit in environments without any risks of explosion, corrosion or fire.
- Make sure that the unit is supplied an adequate volume of air at both intake and outlet ends.
- Any use that does not conform to the expected conditions could result in serious consequences for the unit.
- All ordinary and extraordinary maintenance operations must be carried out with the unit switched off, by disconnecting the power supply.
- Wait approximately 30 minutes after switching off the unit before carrying out any maintenance operations to avoid burns.
- During normal operation, human traffic in the area around the machine must be prevented up to at least the required buffer spaces.

ATTENTION

- Before starting any work on the unit, each operator must be perfectly familiar with its operation and its controls, and have read and understood all the technical information contained in this manual.
- It is forbidden to use the unit in conditions or for uses other than what is indicated in this manual and the MANUFACTURER may not be held responsible for breakdowns, accidents or injuries due to failure to comply with this prohibition.
- Do not repair high pressure pipes with welds.
- It is forbidden to tamper with, alter or modify, even partially, the systems or equipment described in the instruction manual, and in particular, the guards and warning symbols required for personal safety.
- It is also forbidden to operate in manners different from those indicated or fail to perform operations necessary for safety reasons.
- Safety instructions are particularly important, as well as general information contained in this manual.

3.2 Product information

ELA It is the range of air condensed liquid chillers with Scroll compressors.

The different versions and numerous power output rates make these units highly versatile and suited to a wide range of system set-ups.

Sizing and selection of individual components have focused on containing energy consumption, aiming to optimize energy savings not just for individual chillers but for the entire system.

The unit is suitable for being installed in environments where noise abatement is fundamentally important, thanks to the possibility of choosing from three soundproofing set-ups.

The configurations available for the refrigerant circuit are:

- Two refrigerating circuits with four or six compressors;
- Four refrigerating circuits with eight, ten or twelve compressors.

3.3 Models and versions

The units in the series ELA are available in the version with total recovery heatpump for 2 and 4 pipes system.

It is possible to choose from different operating noise versions (Standard, Low Noise, Super Low Noise), and the available chilling configurations (Efficiency packs) allow an extensive power range to be covered.

All models are filled with R410A or R454B refrigerants.

The naming methods and the unit configuration options are shown below.

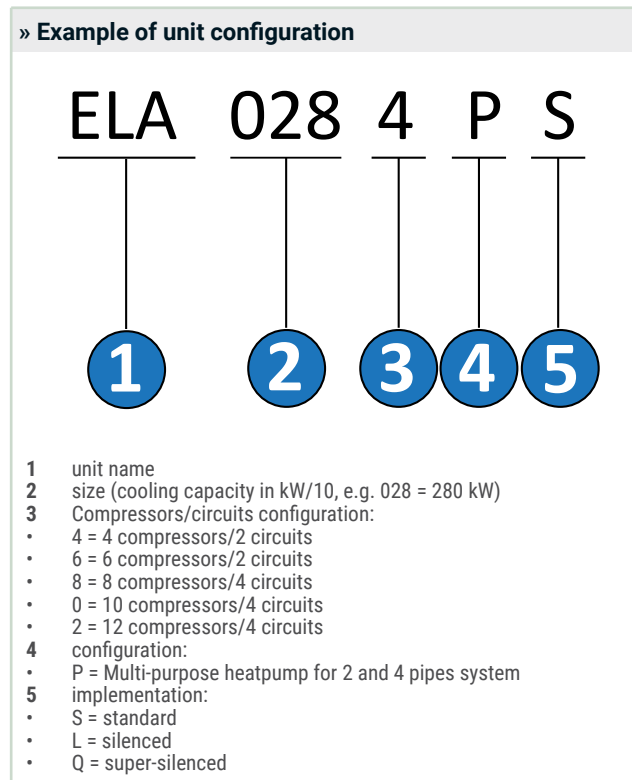

» Configuration options

Version	
Total recovery heatpump for 2 and 4 pipes system	P
Execution	
standard	S
low noise	L
super low noise	Q
Power supply	
400/3/50 + N	0
400/3/50 without neutral wire (with transformer)	1
400/3/50 + N + Circuit breakers	2
400/3/50 without neutral wire + magnetothermal cutoff switches	3
Refrigerant charge	
R410A	0
R410A - A2L ready with gas leakage detector predisposition	A
R454B	B
User side water pump	
none	0
single pump	1
oversize single pump	2
double pump in timed rotation	5
oversize double pump in timed rotation	6

modulating single pump	7
oversize modulating single pump	8
modulating double pump (in timed rotation)	9
oversize modulating double pump (in timed rotation)	A
energy metering kit	
none	0
energy meter	1
energy meter with MID certification	2
cold side energy meter	1
cold side energy meter with MID certification	2
recovery side energy meter	3
recovery side energy meter with MID certification	4
recovery and cold side energy meter	5
recovery and cold side energy meter with MID certification	6
Recovery water pump	
none	0
single pump	1
oversize single pump	2
double pump in timed rotation	5
oversize double pump in timed rotation	6
single modulating pump (electr. Flow switch included)	7
single HP modulating pump (electr. Flow switch included)	8

double modulating pump (standby rotation) (electr. Flow switch included)	9
double HP modulating pump (standby rotation) (electr. Flow switch included)	A
Air flow modulation	
condensation control with phase cut fans	C
condensation control with "EC brushless" electronic control fans	E
Antifreezing kit	
protecting the water exchanger (standard machine)	E
protecting the water exchanger and pump	P
protecting the water exchanger, pump and tank	S
Remote communication	
none	0
RS485 serial board (Carel / Modbus protocol)	1
Lonworks serial board	2
Ethernet board (SNMP or BACNET protocol) + clock board	4
Ethernet board + clock board + supervision software	5
Finned batteries	
standard	0
copper / copper batteries	R
cataphoresis	C
epoxy pre-painted fin and subsequent overall painting	B
pre-painted hydrophilic coated fins	H
Packing	
standard	0
wooden cage	1
wooden crate	2
Anti vibration shock mounts	
none	0
rubber vibration dampers at the base of the unit	G
spring vibration dampers at the base of the unit	M
Documentation language	
italian	I
english	G
german	D
french	F
spanish	S
dutch	N
polish	P
russian	R
List of accessories	
power factor capacitors	A
soft-starter kit	B
service kit (probes kit for quick troubleshooting)	C
two Vic-Taulic joints for fast IN-OUT water connection	D
ON-OFF status of the compressors	E
remote control for power limitation	F
configurable digital alarm card	G
set point compensation outdoor temperature probe	H
manometers	I
filter shut-off kit (tap on liquid line)	L
special cable according to VDE regulation	M
remote display for programmable microprocessor	N
coil protection grille	P
metal filters for coil protection	Q
one Y-shaped water filter loose delivered	R
unit without refrigerant charge	S
measurement and limitation of the absorbed current	T
shut-off valves on compressor tandem / trio	U

3.4 Main technical specifications

For the main technical data of the range ELA see Product Document.

WARNING

The technical data of the manual refer to the standard range, without optional devices, and are subject to changes without prior notice aimed at improving the product.

4 SAFETY PRESCRIPTIONS

The following are some general rules useful for ensuring the safety of people who are in contact with the unit.

ATTENTION

It is up to the installer and the owner of the installation site to define the safety and protection devices to be used for unit maintenance operations or in dangerous situations - as well as the emergency procedures to be adopted in the latter case. All this in accordance with current legislation and in conjunction with local rescue units.

4.1 General safety rules

4.1.1 Thoroughly know the unit

The unit must only be used by qualified personnel, who are expected to know the arrangement and function of all controls, instruments, indicators, indicator lights and various data plates.

4.1.2 Wear protective clothing

Each operator must use personal protective equipment such as gloves, headgear, safety goggles, safety shoes, and hearing protection.



ATTENTION

Please also refer to the relevant section in chapter 14 Safety data sheet of refrigerant p. 51.

4.1.3 Use safety equipment

A first aid kit and a fire extinguisher must be placed near the unit.

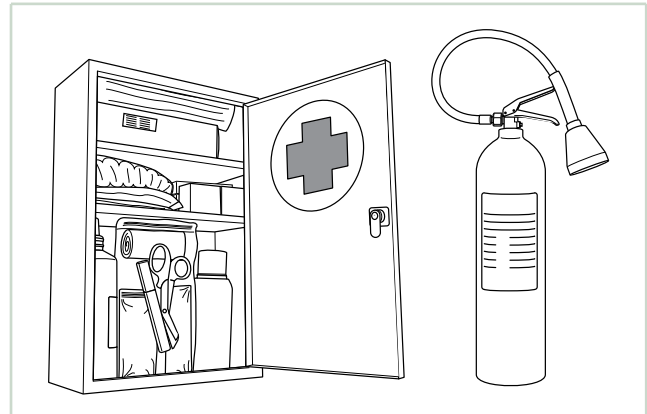

ATTENTION

Please also refer to the relevant section in chapter 14 Safety data sheet of refrigerant p. 51.

4.1.4 Fire extinguisher and a first aid kit

Check the presence and location of the fire extinguisher. Regularly check that the fire extinguishers are charged and their operating instructions are clearly understood. It is required to be aware of where the first aid box is kept. Periodically check that the first aid kit is stocked with disinfectants, bandages, drugs, etc. The personnel must know what to do in the event of a fire. Make sure that emergency help phone numbers are readily available. In the event of a fire, use a fire extinguisher in compliance with the regulations in force. Contact the fire department.

WARNING

The owner of the building where the unit is installed must provide the required fire extinguisher.

4.2 General precautions

The Machinery Directive 2006/42/EC provides the following definitions (Annex 1.1.1.1):

DANGER ZONE: any area next to and/or inside a machine, where the presence of an exposed person constitutes a risk for the safety and health of said person.

EXPOSED PERSON: any person found entirely or partially within a danger zone.

OPERATOR: the person or persons installing, operating, adjusting, maintaining, cleaning, repairing or moving machinery.

WARNING

- Before carrying out any operation or maintenance on the unit it is mandatory to read and follow the instructions given in the use and maintenance manual. During the actual work, it would be too late: any not recommended

or wrong operation could then cause serious damage to people or property.

- The employer must inform in detail all operators about the risks of accidents and particularly about risks related to noise, required personal protective devices and general accident prevention rules provided by laws or international standards and national standards in the Country of destination of the unit. All operators must comply with the international accident prevention standards and standards in force in the country of destination of the unit. Please be reminded that the European Union has issued some directives concerning the safety and health of workers, among which the directives 89/391/EEC, 89/686/EEC, 89/654/EEC, 2009/104/EC, 89/656/EEC, 2003/10/EC, 92/58/EEC and 92/57/EEC that each employer has an obligation to observe and to enforce. In the event that the unit is installed outside the European union, always refer to the regulations in force in the country of installation.
- Before starting any work on the unit, each operator must be perfectly familiar with its operation and its controls, and have read and understood all the information contained in this manual.

ATTENTION

It is forbidden to tamper with or replace parts of the unit unless this has been expressly authorised by the MANUFACTURER.

The use of accessories, tools, consumables or spare parts other than those recommended by the MANUFACTURER and/or specified in this manual may be a hazard to operators and/or damage the unit.

Any alteration of the unit not expressly authorised by the MANUFACTURER shall not imply any civil or criminal liability for the manufacturing company.

WARNING

- It is strictly forbidden to remove or tamper with any safety devices.
- Any installation, ordinary and extraordinary maintenance operations must be carried out with the unit stopped and without power supply.
- Once the unit has been cleaned, the operator must check that there are no worn or damaged parts or parts that are not safely fixed, or if this is the case, ask the maintenance staff to fix the problem. Special attention must be paid to the state of repair of the pressurised pipes or other parts exposed to wear. It must also be ensured that there are no leaks of fluid, or other dangerous substances. In these cases, it is forbidden for the operator to restart the unit before the situation has been remedied. If any of these occurrences are detected, the operator, before leaving the unit unattended, must display a warning sign indicating that maintenance is in progress and it is forbidden to start the unit.
- The use of flammable fluids in cleaning operations is prohibited.
- Periodically check the condition of the data plates and arrange, if necessary, for them to be restored.
- The operator work place must be kept clean, tidy and free from any objects that may limit unhindered movement.

- Operators should avoid operating the device from unsafe, uncomfortable positions that may affect their balance.
- Operators must be aware of possible risks of entrapment and entanglement of clothes and/or hair in moving parts; it is recommended to wear caps over long hair.
- Wearing chains, bracelets and rings can also be dangerous.
- The workplace must be adequately lit for the intended operations. Insufficient or excessively bright lighting can imply safety risks.
- The instructions, accident-prevention rules and warnings contained in this manual must be observed at all times.

4.2.1 Safety information

The units have been designed and built according to the current state of the art and the technical rules currently applicable to fluid chillers and heat pumps intended for cooling water or water and anti-freezing agent mixtures, for housing air conditioning and industrial cooling systems. Compliance with the laws, provisions, prescriptions, orders and directives in force for these machines has been ensured.

The materials and the equipment parts used, as well as the production, quality assurance and control processes meet the highest safety and reliability requirements.

By using them for the purposes specified in this user manual, by operating them with the required diligence and performing accurate maintenance and overhauling in a workmanlike manner, consistent performance and functionality and durability can be ensured.

4.2.2 Accident prevention

The MANUFACTURER will not be liable for accidents, during the use of the unit, due to failure by the user to comply with laws, provisions, prescriptions and regulations applicable to fluid chillers and heat pumps.

4.2.3 Operational safety

The MANUFACTURER will not be responsible in case of malfunctions and damage if the unit:

- it is used for purposes other than those for which it is intended;
- it is not operated and maintained according to the service standards specified further on in this manual;
- it does not regularly and consistently receive maintenance as prescribed or non-original spare parts are used;
- is modified or some components are replaced without the MANUFACTURER's written authorisation, especially when the effectiveness of the safety systems has been altered or minimised on purpose;
- it is used outside the permissible temperature range.

4.2.4 Residual risk areas

DANGER

In some areas of the unit there are some residual risks that could not be eliminated during the design phase nor isolated with guards due to the unit's operating characteristics. Each operator must be aware of the residual risks present in this unit in order to prevent any accidents.

» Residual risk areas

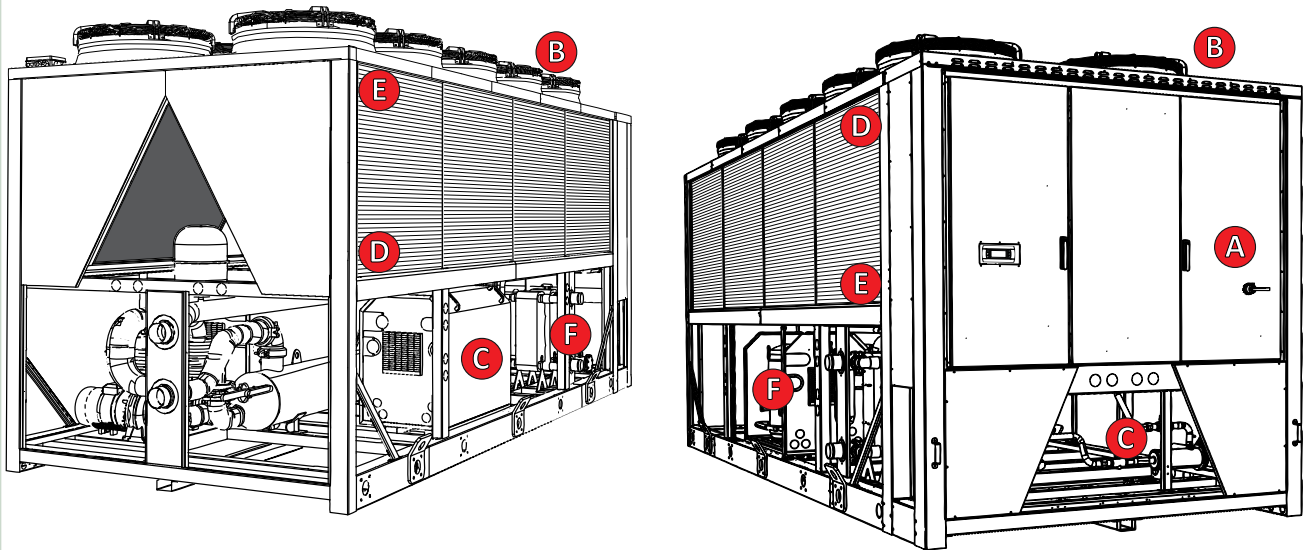

- A. Danger of fire
- B. Impact and abrasion hazard in fan area
- C. Danger of explosion due to the presence of pressurised circuits
- D. Danger of pollution due to the presence of refrigerant in the circuit
- E. Danger of cutting injuries near finned exchangers
- F. Danger of burns due to the presence of high temperature pipes

 **WARNING**





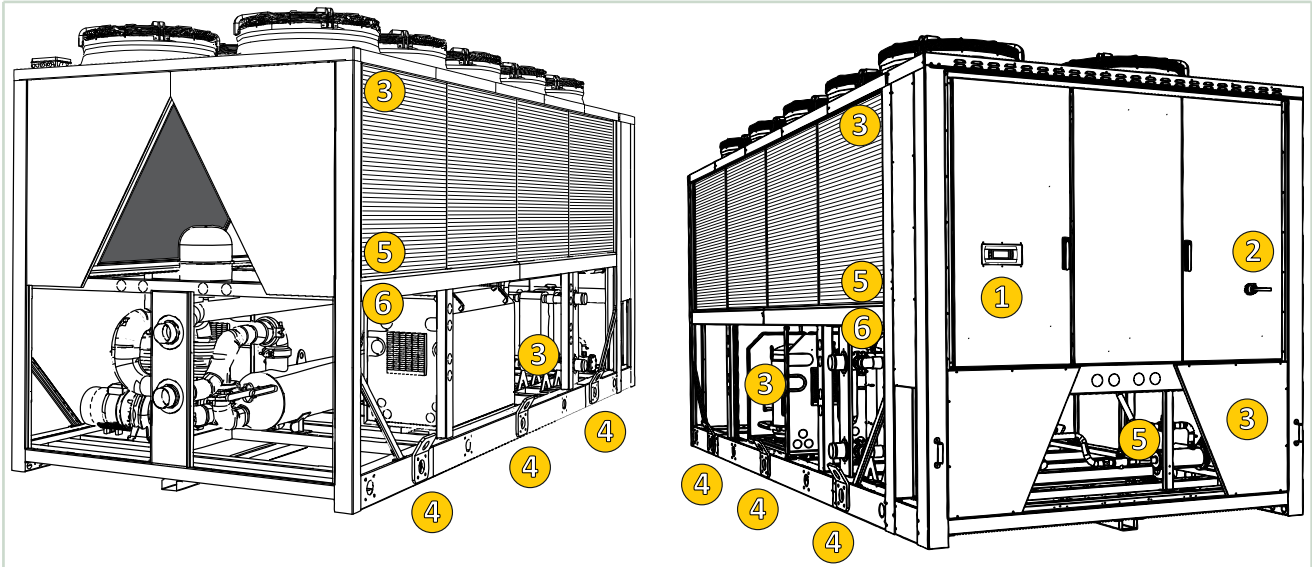

In order to avoid the risks listed above it is essentially important to:

- set the control panel according to the manufacturer's instructions;
- to avoid the risk of impact or abrasion in the fan area, cut off the power to the unit before intervening;
- not place metal objects inside the electrical control panel;
- not store flammable materials near the machine;
- not alter any component of the refrigerant circuit;
- not let the machine work outside the limits indicated by the manufacturer;
- dispose of all the materials that make up the machine correctly, use suitable equipment for the recovery of the refrigerant gas (see chapter 13 Retiring the unit p. 49);
- not touch the internal components during operation without adequate protection.

4.3 Location of safety data plates

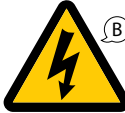
4.3.1 Description of the safety symbols



<p>1</p> <p>A. Warning: danger due to poor familiarity with all the functions of the unit and the resulting risks. B. Read the use and maintenance manual carefully before operating the unit.</p>	<p>(A)  (B) </p>
<p>2</p> <p>Electric power supply data plate</p>	<p>ALIMENTAZIONE ELETTRICA POWER SUPPLY SPG.VERSORGUNGSTEIL 400V/3+N/50Hz</p>
<p>3</p> <p>A. Danger: hot parts. B. Danger: live parts. C. Danger of burns. D. Danger of cutting injuries in the finned exchangers area.</p>	<p>(A)  (B)  (C)  (D) </p>
<p>4</p> <p>Anchor points for lifting</p>	<p>PUNTO DI SOLLEVAMENTO LIFTING POINT HEBEPUNKT</p> 
<p>5</p> <p>Refrigerating liquid</p>	<p>R410A R454B</p>
<p>6</p> <p>Charge connection without core valve</p>	<p> Attacco di carica senza spillo Charge connection without core valve Noyauladeanschluss ohne Ventil</p>

4.4 Maintenance precautions

4.4.1 Tools

Use only tools suitable for safe service and maintenance operations. Personal injury is prevented by not using worn or damaged, low quality or makeshift tools. If tools not recommended or modified without authorisation are used, the manufacturer will no longer be liable for damages caused.

4.4.2 Personnel

Ordinary maintenance prescribed in this manual must only be performed by authorised and trained personnel. For the maintenance or overhauling of components not specified in this manual, contact the MANUFACTURER.

4.4.3 Keep the unit clean

Oil and grease stains, misplaced tools or broken pieces are harmful to people as they can cause slipping or falls. Always keep the area where the unit is installed clean and tidy. Do not use diesel fuel, oil or solvents to clean the unit as the first two leave an oily film that makes it easier for dust to stick, while solvents (even milder ones) damage the paint finish and cause rusting. If a water jet hits the inside of electrical equipment, in addition to causing contact oxidation, it may cause the unit malfunction. For this reason, do not use water or steam jets on sensors, connectors or any electrical parts.

4.4.4 Warning plates

Before starting any maintenance operation, turn off the unit. If other people start the unit and operate the control buttons while maintenance operations are being performed, serious injury or even death may result. To avoid these dangers, before carrying out maintenance, hang caution signs around the unit.

4.4.5 Warnings for inspections and maintenance

Display a sign with the warning: "INSPECTION IN PROGRESS" on all sides of the unit. Check the unit carefully following the list of operations contained in this manual.



4.4.6 Care and maintenance

The cause of damages and accidents is often attributable to wrong maintenance, such as:

- no water in the circuit;
- incorrect percentage of anti-freezing agent in the hydraulic circuit;
- inadequate refrigerant;
- poor cleaning in the unit setting;
- circuit inefficiency (damage to the exchangers, pipe connections, tightening of pipes, screws, etc.).

Carry out maintenance work as required: this is also critical for your own safety. Never postpone scheduled repairs. Only assign skilled or authorised personnel to repair tasks. Always observe the following safety rules, even when you are thoroughly familiar with the operations involved:

- always keep the unit and the surrounding area clean;
- before beginning to work, check the perfect efficiency of protective devices;
- make sure that no unqualified or not specially appointed persons enter the unit operating area.

4.5 Precautions in case of refrigerant leakage

In case the unit is charged with an A2L classified refrigerant, (low flammable refrigerant), the unit is provided with one refrigerant leakage sensor inside each compressor box (if present) and inside all separated sections of the electrical box. The following safety chain is applied: EVENT - ACTION - SIGNAL. Each sensor is set on two different concentration thresholds. The threshold is depending on refrigerant type, and listed in the table below:

Refrigerant	Classification	Low level threshold	High level threshold
R454B	A2L	900 ppm	1800 ppm

The following image and table describe the safety chain EVENT - ACTION - SIGNAL

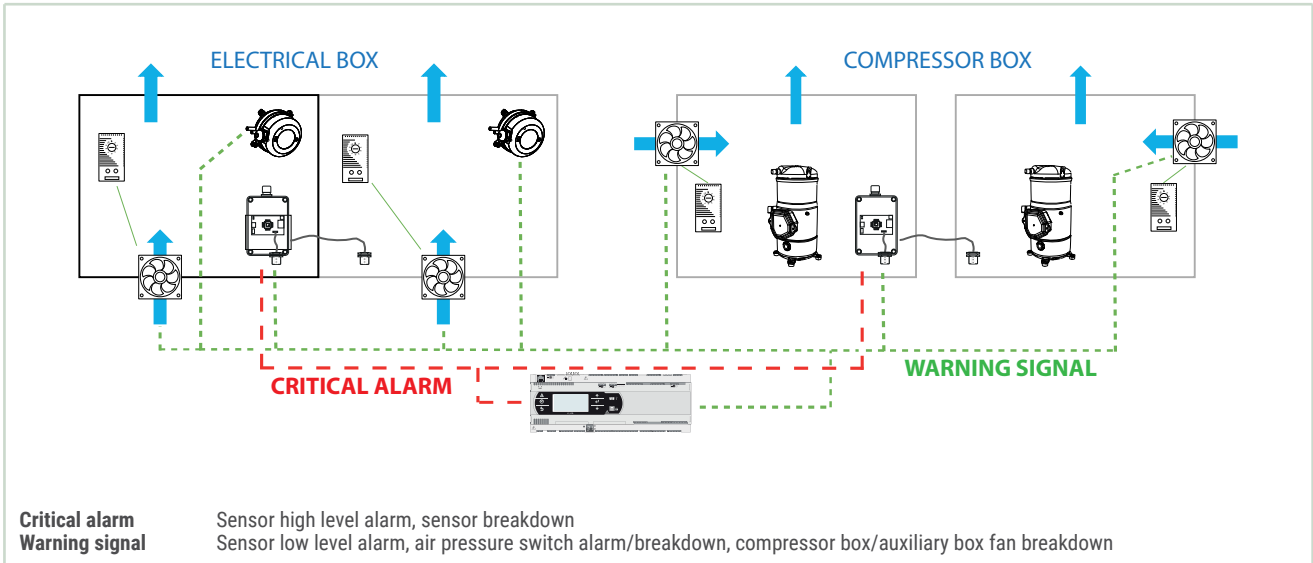

EVENT	ACTION	SIGNAL
Compressor box fan alarm fault	Electrical box fans activation (when $T_{air} \leq T$ limit)	Dedicated warning signal
Underpressure inside electrical panel alarm/fault	Compressor box fans activation	Dedicated warning signal
Low level alarm	Compressor box fans activation Electrical box fans activation (when $T_{air} \leq T$ limit)	Dedicated warning signal
Refrigerant sensor fault	Switch off all the unit (electrical supply still present)	General serious alarm + Dedicated serious alarm
High level alarm	Switch off all the unit (electrical supply still present)	General serious alarm + Dedicated serious alarm

⚠ DANGER

Refrigerant safety devices are not active when the unit is not powered: risk of refrigerant presence in the electrical panel. Check any refrigerant leaks with a suitable device before starting the unit.

- Check the cooling circuit for leaks.
- Once the circuit is set up and the refrigerant charge is restored, close the compartments and power up the chiller, if there are no alarms, the machine can be restarted.

👉 WARNING

Follow the instructions below in the event of a refrigerant leak signal from the sensors installed on the machine or possibly present near the machine:

- In case of low level alarm, contact technical support.
- Do not stand in the vicinity of the machine.

It is necessary to have a remote refrigerant alarm signal, so that it is not necessary to approach the machine in the event of an alarm. This remote signal can be performed:

- Via remote display, available as an option and available at any time by contacting the Eneren After-sales center.
- By reading the unit alarms via remote communication (e.g. via Modbus or Ethernet) and by remotely setting up a specific danger signal far from the unit to activate in the event of an alarm.

⚠ ATTENTION

In case of serious alarm:

- Remove voltage from the unit, keeping the dedicated alarm signal via wired contact active (see wiring diagram).
- Call a service centre for assistance.

Technical assistance must:

- Well ventilate all the closed compartments of the machine well for at least 5 minutes, before energizing.

5 TRANSPORT, INSPECTION, HANDLING, DIMENSIONS AND POSITIONING OF THE UNIT

The following are recommended and necessary indications to correctly carry out transporting, handling and positioning of the unit. To this end, information is also provided regarding the distribution of weights, anti-vibration devices to be used and clearance space around the unit.

5.1 Transport

In order not to damage the structure and components, the units ELA must be fixed to the transport vehicle using the supports shown in the following figure. The image on the left refers to cases including accessories.

» USE THE SUPPORTS TO FIX THE LOAD

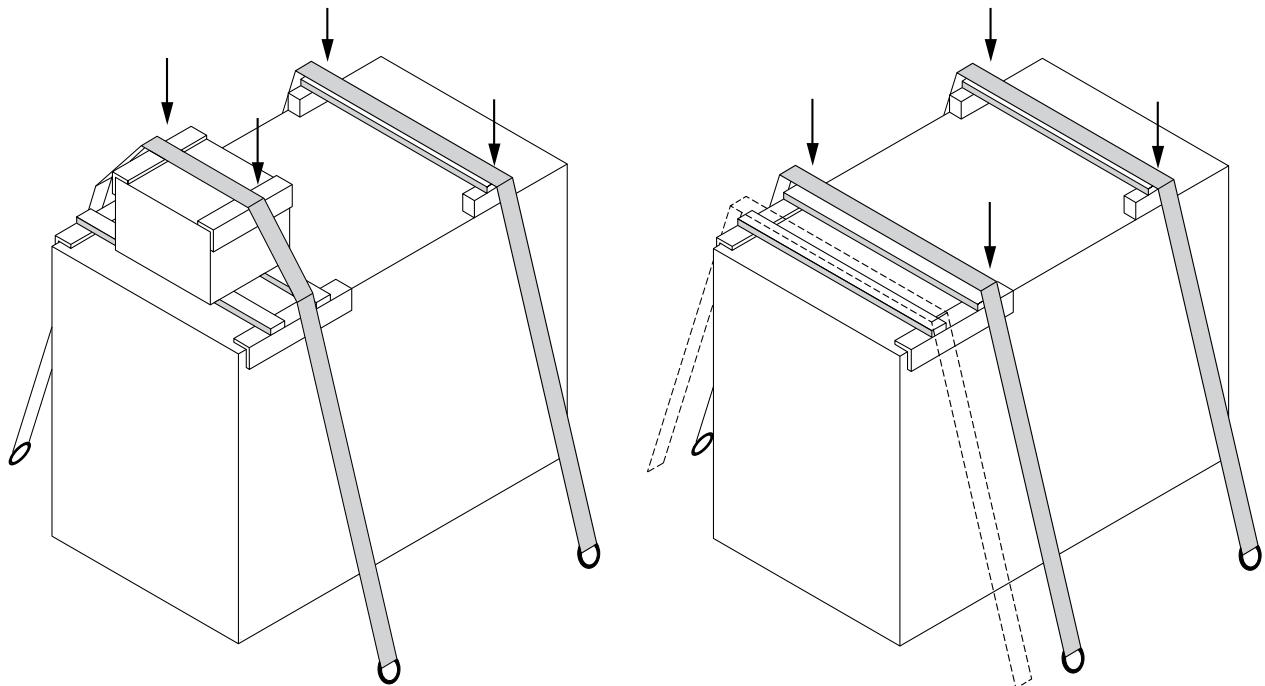

The storage temperature of the unit must be in accordance with the indications in paragraph 8.2 Operating limits p. 31 and on the identification plate on the unit frame. Outside of this range the Manufacturer will not be responsible for any damage that may occur to the unit.

5.2 Inspection

Upon receiving the unit, check its integrity: the machine has left the factory in perfect condition; any damage must be immediately reported to the forwarder and noted on the Delivery report before signing it. In particular, check that the fins of the finned pack exchangers are not bent and have not suffered impacts that could have compromised the pressurised system tightness.

The manufacturers or their agents must be informed as soon as possible about the extent of the damage. The Customer must submit a written report for any significant damage.

Check that the following items are present:

- Start-up instructions
- wiring diagram

Also check the integrity of the documents supplied on-board the machine and attached to this manual.

5.3 Conveyance

During handling, it is mandatory to check the dimensions, weights, centre of gravity and lifting points. Also check that the lifting and positioning equipment complies with the applicable safety regulations.

During the unloading and positioning of the unit, be extremely careful to avoid bumps and knocks or sudden movements. Handling must be carried out carefully and gently, avoiding to apply pressure to any machine components.

Depending on the unit frame, there will be different handling modes.

Frame 1-7S

Rear loading/unloading is strongly recommended using a crane of adequate capacity and following the instructions below.

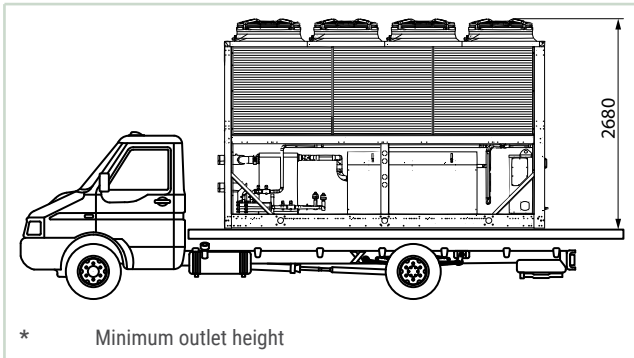
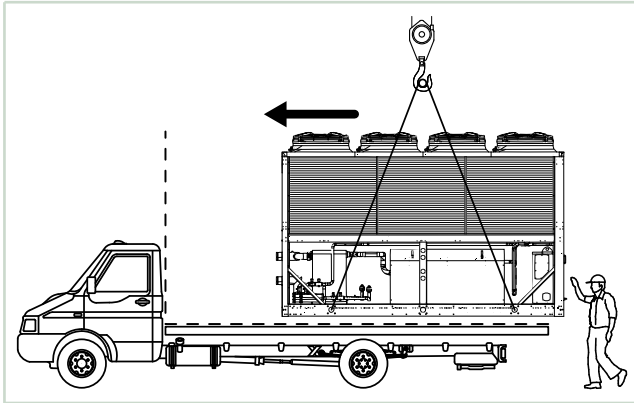

Handling must be carried out by lifting with a crane and suitable ropes or belts of adequate capacity fixed to the eyebolts.

ATTENTION

The upper part and the sides of the unit must be protected by a rigid wooden structure, or by a steel pipe that acts as a spacer between the lifting ropes and the machine.

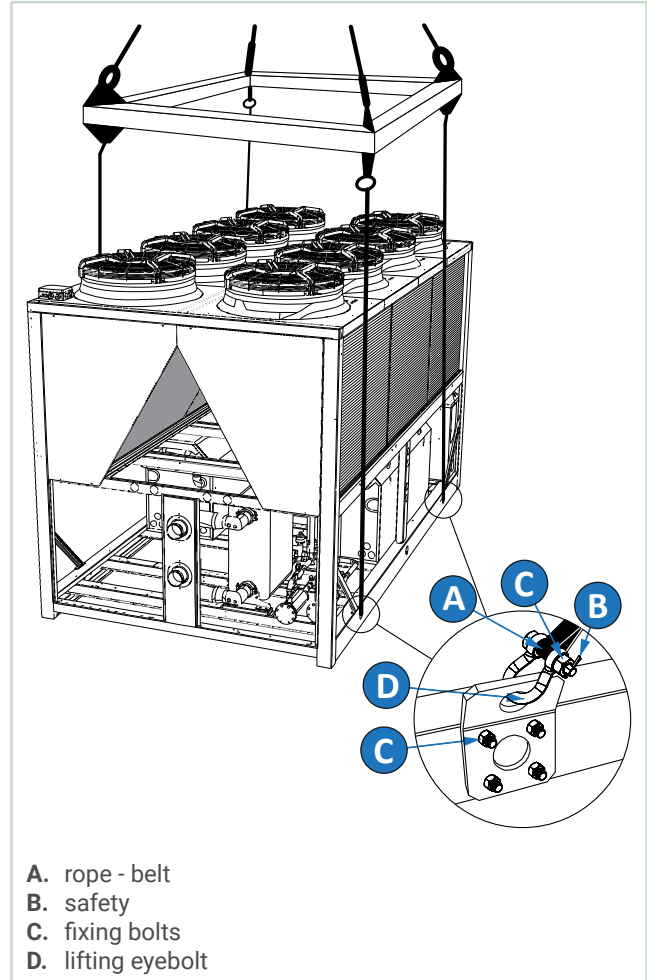

- A. rope - belt
- B. safety
- C. fixing bolts
- D. lifting eyebolt

Lateral loading/unloading via a lift truck is not possible unless by using a low-floor truck (minimum loading clearance 3000 mm) that can be fully opened on the sides and not curtainsided.

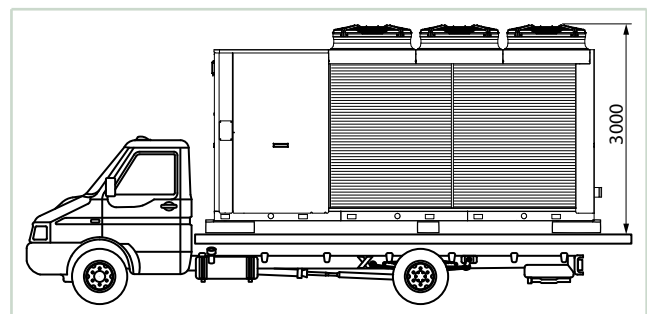

ATTENTION

In all lifting operations make sure that the unit has been securely anchored, in order to avoid overturning or accidental falls. Use all the lifting points.

Once the load has been positioned on the vehicle floor, the unit must be secured with special straps. See the paragraph 5.1 Transport p. 17 for strap fixing instructions.

5.3.1 Dimensions

In the paragraph 3.4 Main technical specifications p. 10 the dimensions are shown for the units in the range ELA.

For more detailed information on space requirements, please refer to the dimensional drawings supplied with the unit.

5.3.2 Weight tables

EMPTY WEIGHT	WEIGHT [kg]				
	S		L-Q		
	Frame	S	Frame	L	Q
ELA294	F1	3202	F1	3312	3662
ELA324	F1	3206	F2	3467	3942
ELA374	F2	3408	F2	3518	3993
ELA404	F2	3451	F3	4561	5161
ELA454	F2	3519	F3	4629	5229
ELA496	F3	4737	F3	4857	5457
ELA556	F3	4797	F4	5617	6342
ELA596	F3	4791	F4	5611	6336
ELA636	F4	5542	F4	5662	6387
ELA676	F4	5593	F4	5713	6438
ELA748	FB	6531	FB	6751	7701
ELA808	FB	6523	FB	6743	7693
ELA868	FB	6591	FB	6811	7761
ELA900	FC	8873	FC	9093	10293
ELA1072	FD	10561	FD	10801	12251

WATER CONTENT	WEIGHT [kg]					
	S		L-Q			Extra single/double pump
	Frame	S	Frame	L	Q	All versions
ELA294	F1	96	F1	96	96	16
ELA324	F1	96	F2	96	96	16
ELA374	F2	109	F2	109	109	16
ELA404	F2	122	F3	135	135	25
ELA454	F2	122	F3	135	135	25
ELA496	F3	135	F3	135	135	25
ELA556	F3	151	F4	151	151	25
ELA596	F3	151	F4	151	151	25
ELA636	F4	151	F4	151	151	25
ELA676	F4	151	F4	151	151	25
ELA748	FB	135	FB	135	135	25
ELA808	FB	135	FB	135	135	25
ELA868	FB	135	FB	135	135	25
ELA900	FC	167	FC	167	167	35
ELA1072	FD	167	FD	167	167	35

5.4 Unpacking

The unit packaging must be carefully removed avoiding possible damage to the machine; the materials that make up the packaging are of a different kinds: wood, cardboard, nylon, etc.

It is good practice to collect them separately and deliver them for disposal or recycling to specialised disposal companies - thus reducing their environmental impact.

ATTENTION

If the unit is equipped with (a) pump(s) and/or a tank, the expansion tank will be packed inside it, to be fixed to the

suction line of the pump where a sealed "TEE" junction is provided, or on the tank itself. Remove the cap and tighten the expansion tank (this should be performed by qualified personnel), and check the pre-charge pressure (0.5/1.0 bar) before filling the water circuit and starting the machine.

The size of the expansion tank depends on the water content of the system as well as on its temperature range; always check the capacity of the tank in relation to the water content of the system.

5.5 Siting and dampers

Check the following points to select the best installation setting for the unit and its connections:

- Size and origin of water pipes;
- power supply location;
- accessibility for maintenance or repairs;
- solidity of the supporting surface
- adequate ventilation of the area (taking into account the maximum permitted ambient temperature);
- application limits of the unit (see chapters 3.1 Scope of application p. 8 and 8.2 Operating limits p. 31).

It is good practice create a support slab of dimensions suitable for those of the unit. This precaution is essential when you want to place the unit on unstable ground (gardens, etc.). It is advisable to place a rigid rubber strip between the base frame and the support surface or, if more thorough insulation is required, it is advisable to use spring type anti-vibration mounts.

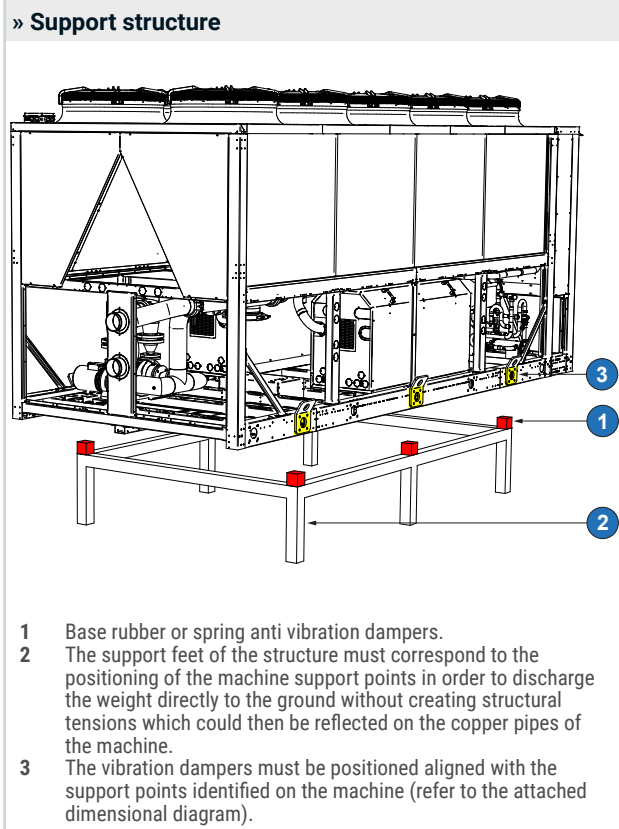

If the machine is installed on a dedicated support structure, take into account the diagram for positioning the machine's support points.

In order to avoid problems during machine operation, is recommended send in advance the drawing and structural calculations of the support structure to the technical department for approval.

In the case of installation on roofs or intermediate storeys, the unit and pipes must be insulated from walls and ceilings by placing rigid rubber joints in between and using supports that are not rigidly anchored to the walls.

If the unit is to be installed in proximity to private offices, bedrooms or areas where noise levels must be kept down,

it is advisable to conduct a thorough analysis of the sound field generated and verify its compatibility with the local laws in force.

5.5.1 Anti-vibration rubber devices

The units ELA can be equipped with spring-type anti-vibration rubber mounts. The following table provides a summary of rubber anti-vibration elements adopted for this series, depending on the frame.

The machine is guaranteed to work with the vibration dampers supplied with it and positioned according to the machine diagram (attached). If vibration dampers other than those supplied are used, without the manufacturer's authorisation, the guarantee on noise, vibrations and any breakages deriving from the same will expire.

Frame	Rubber anti-vibration mount
F1	BSB 180 50°SH
F2	BSB 180 50°SH
F3	BSB 180 50°SH
F4	BSB 180 60°SH
F5S	BSB 180 50°SH
F6S	BSB 180 50°SH
F7S	BSB 180 60°SH

The following paragraph describes in detail the properties of the anti-vibration devices mentioned above. For the exact position of each foot, refer to the attached dimension drawing.

Frame 1-7S

- Frame F1, F2, F3, F5S, F6S: BSB180 for 50° Shore hardness
- Frame F4, F7S: BSB180 for 60° Shore hardness

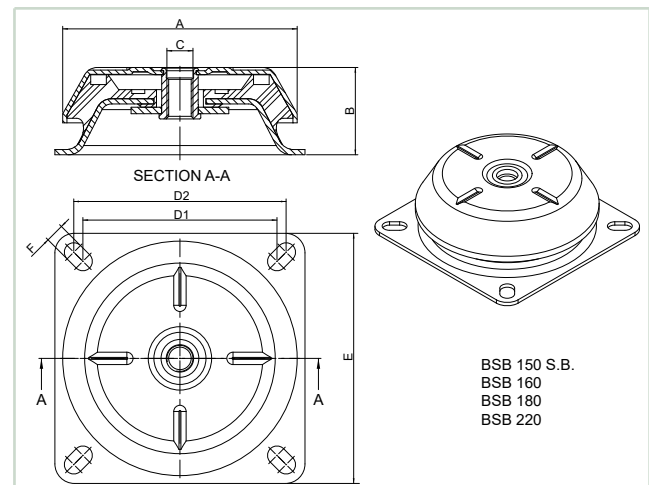

CODE		BSB180	BSB180
A	mm	180	180
B	mm	67	67
C	mm	M-20	M-20
D1	mm	149	149
D2	mm	163	163
E	mm	192	192
F	mm	14.5	14.5
WEIGHT	g	3800	3800
LOAD	kg	1750	2100
HARD-NESS		50 Sh	60 Sh

The values shown are approximate figures only - due to elastomer hardness tolerance range and other factors; they can be reassessed in case of actual need.

» OWN FREQUENCIES Type BSB

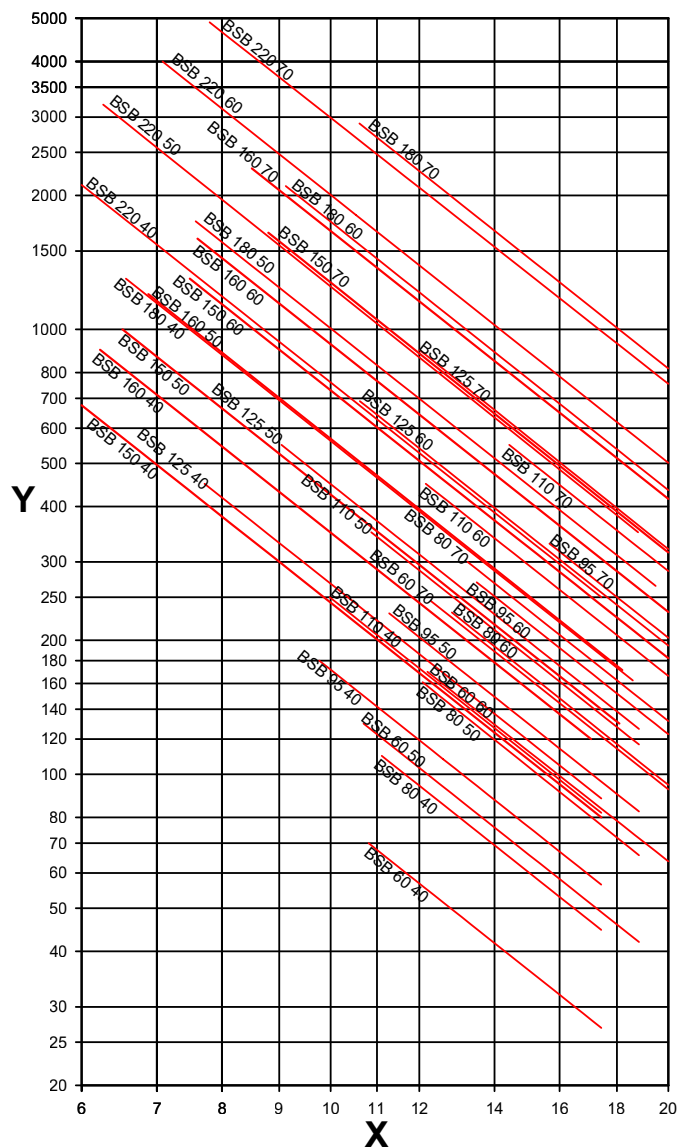

X own frequency Hz
Y load (kg)

» LOAD-DEFLECTION CURVES Type BSB

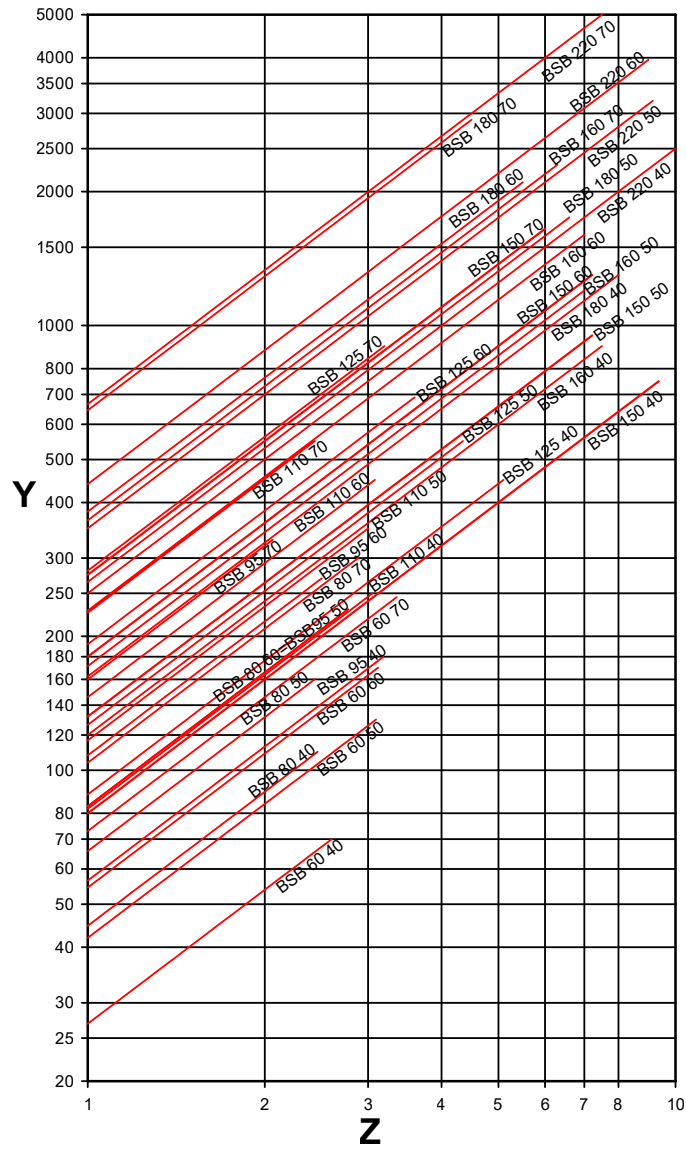

Z bending (mm)
Y load (kg)

5.5.2 Anti-vibration spring devices

The ELA units can be equipped with the spring-type anti-vibration devices shown below.

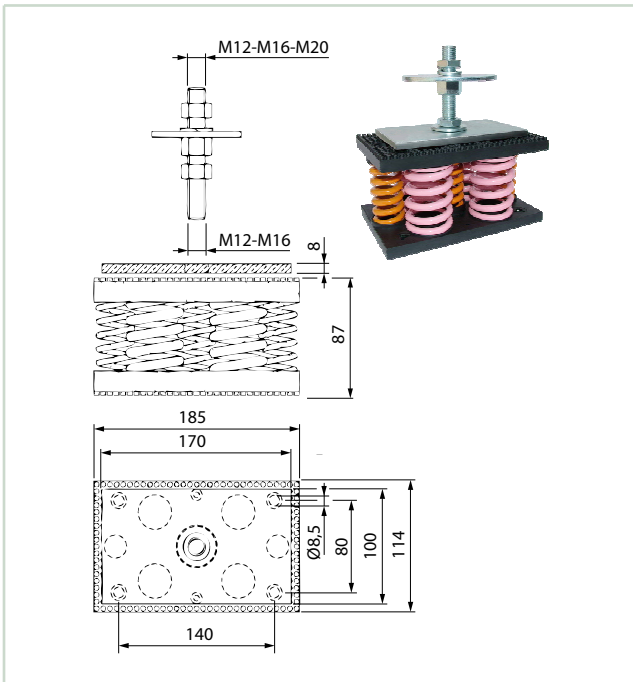

The following table provides a summary of the spring anti-vibration mounts adopted for this series, depending on the frame.

Frame	Spring anti-vibration device
F1	RF411-Z220-124
F2	RF411-Z220-124
F3	RF411-Z220-124
F4	RF412-Z220-X108
F5S	RF411-Z220-124
F6S	RF411-Z220-124
F7S	RF412-Z220-X108

The following paragraph describes in detail the properties of the anti-vibration devices mentioned above.

For the exact position of each foot, refer to the attached dimension drawing.

Frame F1, F2, F3, F5S, F6S

» Anti-vibration mount: RF411-Z220-124

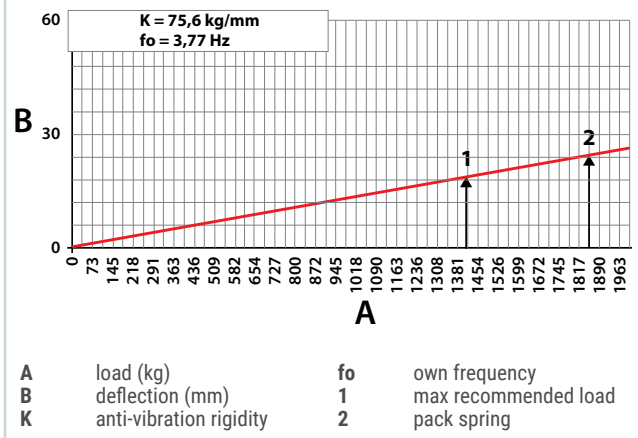

Frame F4, F7S

» Anti-vibration mount: RF412-Z220-X108

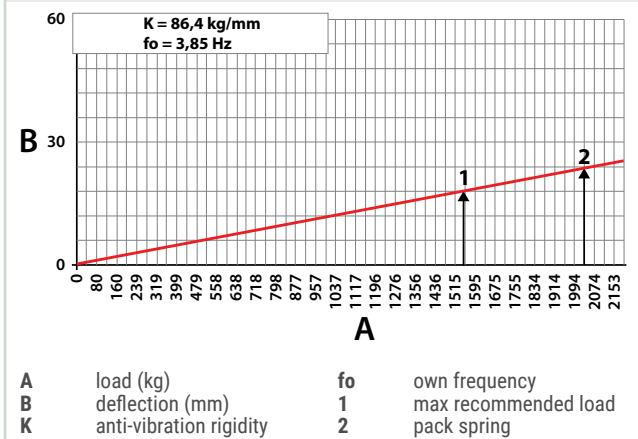

5.6 Installation clearance requirements

Ensuring sufficient clearance spaces is of critical importance as it ensures an adequate volume of air at both the intake and the delivery ends of the external heat exchangers and avoids recirculation between the two airflows. Failure to do so would result in poorer unit performance or even discontinuance of normal operation. An adequate service space also allows for ordinary maintenance operations to be carried out.

The distances to be observed are the following:

- rear side/connections: minimum 1.5 m;
- control panel side: minimum 1.5 m;
- side parts: minimum 2 m;
- top side: there must be no obstacle to air outlet.

In special cases these requirements can be changed according to design department decisions.

» View from above

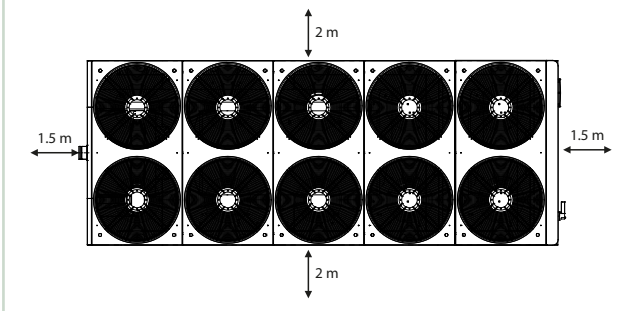
⚠ DANGER

During normal operation, human traffic in the area around the machine must be prevented up to at least the required buffer spaces.

⚠ ATTENTION

In the event of installing several machines close together, the clearances between the machines must be double those indicated in this manual and/or in the attached dimensional drawings.

6 PLUMBING AND ELECTRICAL CONNECTIONS

6.1 Hydraulic connections

This paragraph provides the necessary instructions that must be followed for a correct hydraulic connection of the unit.

ATTENTION

All operations must be performed EXCLUSIVELY BY QUALIFIED PERSONNEL, in compliance with the regulations applicable in the country of installation.

WARNING

In any case, please also refer to the document "First start up instructions", supplied with the unit.

It is mandatory to install a metal mesh filter on the inlet pipe with a recommended 1 mm mesh size, to protect the exchanger from residues or impurities in the pipes. If the machine works in combination with process cycles, it is advisable to install an inspectable uncoupling exchanger, in order to avoid possible lockups and/or breaks of the plate heat exchanger. Note that the units are designed to operate in a **closed** hydraulic circuit.

In the case of open tanks, it is advisable to contact the design department which will indicate the best solution to adopt, such as uncoupling the exchanger.

6.1.1 General guidelines for plumbing connections

When preparing the hydraulic circuit for plate heat exchangers, it is highly recommended to follow the instructions given below, and in any case, comply with national or local regulations (refer to the diagrams included in the manual).

1. Connect the pipes to the chiller using flexible couplings to prevent the transmission of vibrations and to compensate for thermal expansions. These units are all configured for installation of the water inlet-outlet pipes outside the unit (on the rear) and these pipes are supplied as standard accessories at no extra cost for the customer.
2. Install the following components on the piping:
 - pair of quick couplings with welded socket (optional - selectable from price list). They make system connection operations easier and the installation tasks very quick;
 - temperature and pressure indicators for routine group maintenance and inspections. Pressure monitoring on water side allows the efficiency of the expansion tank - if any - to be ensured, alerting to any system water leaks early on. **N.B.:** check that the water pressure on the suction side of the pump is at least 0.6 bar; otherwise, the storage tank could be damaged.
 - Sumps on the inlet and outlet pipes for temperature measurements through direct viewing of the operating temperatures. They can, however, be checked by means of the on-board microprocessor;

- shut-off valves (gate valves) to isolate the unit from the hydraulic circuit;
- vent valves, to be located in the highest parts of the hydraulic circuit, to allow for air bleeding. On the internal machine pipes there are smaller vent valves for on-board machine air bleeding: **this operation must exclusively be carried out with no electric power supply to the group.** Make sure that the circuit is completely filled with water, then bleed the air from the water heat exchangers in order to avoid pump cavitation.
- discharge cock and, where needed, drain tank in order to empty the system for maintenance or seasonal stops. (Drainage valve of 1" is provided on the optional water buffer tank: **this operation may only be carried out when the unit is disconnected from the power supply**);

WARNING

If the unit is intended for the production of domestic hot water, the use of an uncoupling exchanger between the unit's hydraulic circuit and the domestic hot water circuit is mandatory.

» Quick couplings (optional)

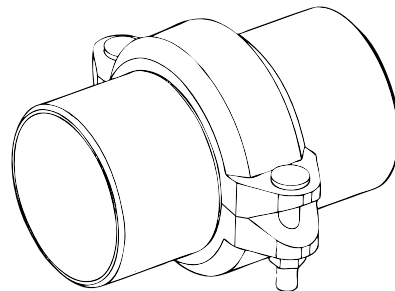

6.1.2 Recommended water circuit

ATTENTION

During hydraulic connection operations, never work with naked flames near or inside the unit.

The recommended hydraulic circuit is shown in figure Recommended water circuit. It is equipped with:

- valves for regulating (VI) the unit on the water pipes, immediately upstream and downstream from the unit itself, to be used in the event maintenance work is required;
- a mechanical filter (F) (MANDATORY!) on the pipe at machine inlet next to it;
- a mechanical filter (F) (MANDATORY!) and a check valve (VR), on the supply line upstream from the filling tap (RC);
- an air vent in the highest point of the installation, to allow for air bleeding;
- safety valve conveyor pipe (VS), which, if the valve is opened, directs the water jet to areas where it cannot damage people or property (Important!);

- anti-vibration joints (AV) on the pipes to prevent vibration transmission to the system.

ATTENTION

Regarding the choice of mechanical filters, the degree of filtration adopted, expressed as “maximum particle size” (mm), is as follows:

- 0.9 mm for ELA up to size 324
- 1.1 mm for ELA from size 364.

It is a good rule for the pipes departing from and returning to the unit not have a smaller diameter than the unit hydraulic connections’.

During the winter it is necessary to empty the system (or the chiller only) to avoid damage caused by freezing; alternatively, load the system with a mixture of water and glycol in adequate percentages, chosen according to the lowest expected temperature (see 8.3 Thermal carrying fluid p. 34).

ATTENTION

In case an anti-freezing agent of a different type must be used, please contact the office.

Failure to install filters and anti-vibration mounts can cause obstruction, breakage and noise problems for which the manufacturer may not be held responsible.

» Recommended water circuit

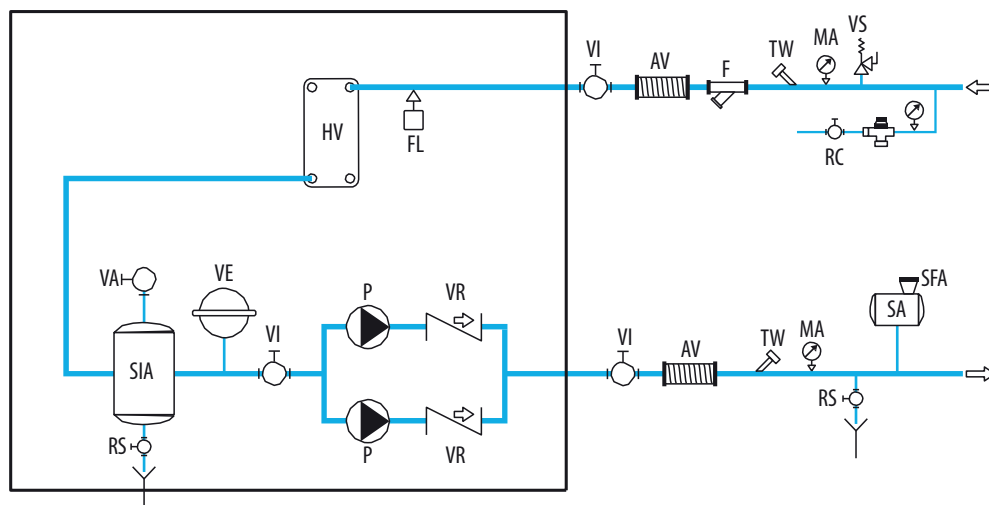

HV	Evaporator
FL	Flow switch
VE	Membrane expansion tank
VA	Manual air vent
SIA	Inertial storage tank
RS	Draining tap
RC	Filling cock
VI	Shut-off valve
VR	Check valve

P	Circulation pump
AV	Anti-vibration mount
F	Metal filter
VS	Spring safety valve
GR	Filling group
SA	Air separator
TW	Water temperature detection trap
MA	Pressure gauge

6.1.3 Flow switch installation

Units ELA from frame 1 to frame 6 feature a flow switch for controlling the water flow as part of the standard equipment. For subsequent frames, the flow switch is supplied as standard, pre-mounted on a suitable steel pipe, and must be installed on the machine.

The pipe has a minimum length suitable for guaranteeing the correct distance from curved pipe sections in the system. Please refer to the dimensional drawing.

A horizontal arrangement of the pipe on which it is mounted is mandatory, to avoid mishaps. To install the flow switch:

- connect the pipe, by means of a vic-taulic coupling, to the unit inlet connector;
- wire the flow switch to the electrical panel as indicated in the wiring diagram.

It is critically important to connect the socket with the flow switch as required to the connector marked “Water inlet”.

6.1.4 Hydraulic connection to the plate heat exchanger

ATTENTION

It is critically important that water inlet occurs at the connection marked with the words “Water Inlet”.

Otherwise, there would be a risk of freezing the plate heat exchanger, since there would be no control by the antifreeze thermostat and the countercurrent circuit operation requirement during cooling would not be met - with added risks of malfunctioning.

The dimensions and the position of the hydraulic connections are shown in the assembly drawings of this manual and of the attached documents.

ATTENTION

- The hydraulic circuit must be designed in such a way as to guarantee the consistency of the rate water flow (+/- 15%) to the exchanger in all operating conditions.
- On the units ELA a device is provided for controlling the water flow (paddle type flow switch) on the hydraulic circuit, in the immediate vicinity of the plate heat exchanger. If this device is tampered with, the guarantee is no longer valid.
- It is strongly recommended to install a safety valve on the hydraulic circuit (already installed if there is an expansion tank). In case of severe system faults (e.g. fire) it will allow the system to be drained, avoiding possible explosions. Always connect the outlet to a pipe with a diameter not smaller than that of the valve opening, and direct it to areas where the jet is not likely to harm people. For units equipped with an (optional) storage tank or pump kit(s), it is part of the standard equipment.

DANGER

During hydraulic connection operations, never work with naked flames near or inside the unit.

The compressors' action is intermittent, as the refrigeration requirements of the user may not match the supply from the unit. In systems with a low water content, where the water thermal inertia effect is less sensitive, it is advisable to check that the water content of the delivery section to the users matches the following ratio:

$$V = \frac{C_c \times \Delta t}{\rho \times Sh \times \Delta T \times N_s}$$

V	water content in the user section [m ³]
Sh	fluid specific heat [J/(kg/°C)]
ρ	fluid density [kg/m ³]
Δt	minimum time between 2 restarts of the compressors [s]
ΔT	permitted waterT differential [°C]
Cc	refrigerating power [W]
Ns	No. of partial loading steps

Regardless of their configuration, all the groups have a single external hydraulic connection (inlet + outlet). This is an important factor which shortens on-site connection times. Normally, each group is provided with a flow switch which immediately stops the group in case of faults, thus preventing the plate heat exchanger from freezing or being damaged. A water temperature probe is also provided on the outlet side of the plate heat exchanger, which is connected to the antifreeze thermostat.

For all groups there are options that allow various configurations to be created with:

- single or double pumps for applications at -10°C and with maximum 40% ethylene and propylene glycol (available for applications with > 40% glycol on request, by contacting the design department);
- storage tank at the hydraulic circuit outlet end. This system facilitates the balancing of the inevitable temperature fluctuations following compressors on/off.

The following figure shows the integrated and balanced effect of the storage tank. Its function helps ensure accurate temperature control according to the environmental parameters of the connected groups.

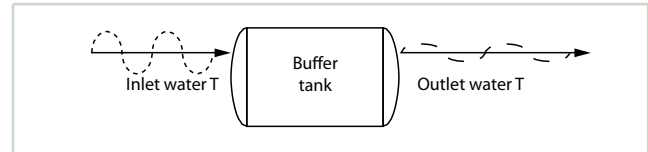

6.1.5 Filling the system

- Before you start filling, make sure that the system draining tap is closed.
- Open all the air vent valves of the system and of the indoor units and chiller.
- Open the system regulating devices.
- To fill the circuit open slowly the water tap of the system (optional).
- When water starts coming out of the air vent valves of the indoor units, close them and continue filling until the pressure gauge reading is 1.5 bars.

The quality and chemical composition of the cooling and heat transfer medium have a great influence on the Lifetime and on heat transfer and thus on the performance of the ELA.

Basically, all types of Avoid floating matter in the cooling and heat transfer medium.

When the suspended matter accumulates in the heat exchanger the heat transfer and thus the performance of the ELA deteriorate.

Below are the values of the dissolved substances and the water properties recommended by the manufacturer listed. The information refers to the use of exchangers made of copper, AISI 304 or AISI 316.

If the concentration of some components will be out of range, the customer has to introduce a correction, otherwise the system will be out of warranty.

WATER CONTENT	CONCENTRATION
Alkalinity (HCO ₃ ⁻)	70 - 300 ppm
Sulphate (SO ₄ ²⁻)	< 70 ppm
HCO ₃ ⁻ / SO ₄ ²⁻	> 1.0 ppm
Electrical conductivity	10 - 500 µS/cm
pH*	7.5 - 9.0
Ammonium (NH ₄ ⁺)	< 2 ppm
Chloride (Cl ⁻)	< 30 ppm
Free chlorine (Cl ₂)	< 0.5 ppm
Hydrogen sulphide (H ₂ S)	< 0.05 ppm
Carbon dioxide (CO ₂)	< 5 ppm
Total hardness (°dH)	4.5 - 8.5
Nitrate (NO ₃ ⁻)	< 100 ppm
Iron (Fe)**	< 0.2 ppm
Aluminium (Al)	< 0.2 ppm
Manganese (Mn)**	< 0.05 ppm
Calcium carbonate (CaCO ₃)	< 200 ppm
Phosphate (PO ₄ ³⁻)	< 2 ppm
Ammonia (NH ₃)	< 0.5 ppm
Temperature (°C)	< 65 °C
Oxygen content	< 0.1 ppm

*Generally a low pH value (less than 6) increases the risk of corrosion and a high pH (above 7.5) decreases the risk of corrosion
 **Fe³⁺ and Mn⁴⁺ are powerful oxidants and may increase the risk of localized corrosion on stainless steel

6.2 Tank filling mode

ATTENTION

The tank, if present, is not designed to withstand a negative pressure greater than -0.15 bar. For this reason, make sure that the suction pressure of the pump, where the expansion tank is positioned, is always greater than 0.5 bar with the pump running: this also helps reduce the risk of pump cavitation.

It is essential that the installer follows and verifies point by point the procedure indicated below, to prevent any risk of implosion of the tank or cavitation in the pump:

- A. Drain the expansion tank until pressure is 0.5 bar
- B. Charge the system and pressurise it up to about + 1 bar at the pump suction end (pump not running)
- C. Vent the system
- D. Check the pump suction pressure (about 1 bar) and start the system
- E. Stop the pump after 15-30 minutes and repeat from point c) until there are no more noises caused by air in the system.

6.3 Electrical connections

Before carrying out any operation on electrical parts, make sure that there is no applied voltage.

WARNING

All operations must be performed by qualified personnel, in compliance with the regulations applicable in the country of installation. For any electrical intervention, please refer to

the information shown on the wiring diagram attached to the unit.

Operation must occur within the above voltage value range, otherwise, the guarantee will no longer be valid.

ATTENTION

Check that the mains voltage matches the unit rated data (voltage, phase number, frequency) stated on the data plate on the machine. The input voltage must not undergo fluctuations greater than ± 5% and the unbalance between individual phase voltage values must always be below 2%.

It is the installer's responsibility to choose the power connection cable and to dimension the line protection systems on the basis of the electrical data declared in the silver label and in the wiring diagram supplied, in compliance with the regulations applicable in the country of installation. The wiring diagram shows the data and minimum requirements that may help the installer select a cable and carry out correct dimensioning of the protection devices.

No provisional supply or site supplies are allowed, subject to the immediate loss of validity of the guarantee.

The electrical control panel is designed and wired according to the declaration of conformity enclosed with the unit, completed in accordance with the regulations in force in the country of installation.

To access the electrical control panel and its components, it is necessary to open the external panel provided with pneumatic lifting pistons that keep it in its locked position. However, before opening the unit, disconnect it from the power supply by turning the red main disconnecting switch. All remote and auxiliary controls have 24V voltage supplied by an insulating transformer located in the electrical control panel. The position of the general disconnecting switch has been chosen in order to facilitate wiring operations locally and avoid difficulties in leading the wires through and routing 3+1 power cables.

All components are protected against overload and short circuits. An optional factory setting for automatic thermal protections for all loads can be selected. In any case, thermal protection consisting of a set of thermal sensors in a chain configuration on all connected electric motors is provided as standard. In addition, the compressors are controlled by their respective on-board electronics that also control the oil and phase sequence alarms.

All the devices are usually provided with a general phase sequence relay which, in addition to ensuring internal protection, also ensures the correct operation of the compressor(s) when the correct phase indications are not observed. The degree of protection of the electrical panel is IP44 and when the electrical panel is open it still meets IP20 protection class requirements, thanks to the plastic cover on the front of the electrical distribution panel.

The preliminary checks and the electrical connections to be made are as follows (**refer also to the document "First start up instructions", supplied with the unit**):

- Open the main disconnecting switch.
- Insert the power cable through the special hole provided on the left side of the unit (by first removing and drilling the square plate according to the diameter of the electric cable) and lock it with a cable gland.

- Connect the power supply and the earth cable to the terminals of the main disconnect switch.
- Open the protections of the installed compressors to prevent that, in case of a wrong phase sequence, they start in the wrong direction.
- Apply voltage by turning the main switch to ON.
- Check the correct L1 - L2 - L3 direction of the phase wires by checking on the phase sequence relay that the green indicator lights up for voltage presence and also the yellow one for the correct sequence; if this does not happen, disconnect power supply to the machine on the external distribution panel, exchange two phase wires and repeat the operation. **IN NO CASE SHOULD THE WIRING DOWNSTREAM FROM THE GENERATOR BE ALTERED**, because doing so could jeopardize the correct sequence of other devices, for example the pump(s).
- Close the compressor protections.
- Close the control panel.

Earthing is mandatory by law. The installer must provide for the connection of the earthing cable (yellow-green cable) to the special earth terminal located in the electrical control panel.

Power supply to the control circuit is derived from the power line via an insulation transformer located in the electrical control panel.

The control circuit is protected by special fuses or magneto-thermal switches.

All the units are usually equipped with a phase sequence relay which ensures the correct phase sequence, necessary for the machine to be fully functioning before allowing the compressor(s) to start.

ATTENTION

In the event of units equipped with an inverter, as regards the differential electrical protection to be installed upstream, it is necessary to use a type B circuit-breaker that is sensitive to impulsive and direct currents. It is preferable that it has the following characteristics:

- adjustable activation threshold, with a minimum activation threshold of 0.3 A and maximum activation threshold depending on the type and number of inverters and other components installed in the unit;
- adjustable operation delay;
- dedicated switch for the heat pump only.

The differential protection adjustment must be compatible with the type of inverter used and obviously, comply with the legal provisions in force in the country of installation.

It will therefore be necessary, during installation, to check the suitability of the room and the installation setting; any liability for non-compliance may not be attributed to the heat pump/chiller manufacturer.

As far as the main isolating circuit breaker is concerned, an input voltage automatic switching system is provided, padlockable in the OFF position to allow for maintenance, but no external disconnecting operations are required. If an emergency disconnection system is deemed necessary, it must be set up externally during installation. This must be provided by the installer.

The short-circuit current is assumed to be $I_{cc} = 6 \text{ kA}$. If I_{cc} is higher at the point of installation, the installer is requested to provide an adequate circuit breaker system.

In any case, refer to the laws and regulations in force in the country of installation.

6.3.1 Electrical wiring of the circulation pump

For all units of series ELA, the pump kits, if selected during the ordering phase, are pre-wired. For the double pump kits, whether in the "AND" or "OR" versions, the rotation is managed on a time/fault basis.

WARNING

The pump must be started before the chiller starts and stopped after the chiller has stopped (recommended minimum delay: 60 seconds.) If available as an option on the machine, this function is already carried out by the on-board microprocessor.

6.3.2 External enabling controls

If you wish to perform remote ON-OFF controlling of the unit, it is necessary to remove the jumper between the contacts shown on the wiring diagram and connect external enabling to these same terminals (refer to the attached wiring diagram). The subsequent enabling of the "REMOTE" function via the switch in the electrical panel is only possible if a basic type microprocessor control is used.

If the unit can be used in both the cooling and the heating modes, to carry out remote switching between summer and winter modes it is necessary to remove the jumper between the contacts shown on the wiring diagram and connect external enabling to these same terminals (refer to the attached wiring diagram). The switching modes are different as a function of changes in the microprocessor control - which can be of a basic or an advanced type: detailed instructions are given in the microprocessor user manual, which is an integral part of the documentation supplied.

WARNING

All external controls and enabling signals at very low 24 Vac voltage are supplied by the insulation transformer available on the control panel.

6.4 Electrical data

For the electrical data of each specific configuration, refer to the silver plate on the unit and to the wiring diagram supplied.

Please be reminded that the electrical components of the unit are dimensioned according to electrical absorption at maximum system PS, i.e. at the maximum admissible pressure (or design pressure) for which the unit has been designed. This also includes safety accessories and electrical cables.

6.5 Hydraulic and refrigeration diagrams

To view the hydraulic and refrigeration diagrams, please refer to the documentation supplied with the unit.

7 MICROPROCESSOR CONTROL

WARNING

To obtain access to all the information related to unit switching on and off, its use, the setting of the working set-point, the display of the alarms and all the parameters related to microprocessor control, possibly linked to customer specifications details, please refer to the dedicated “Microprocessor Manual”, supplied with the unit.

8 START-UP

This paragraph provides the necessary instructions that must be followed for correctly starting the unit.

WARNING

In any case, please also refer to the document “First start up instructions” and to the “Microprocessor Manual”, supplied with the unit.

8.1 Preliminary checks

Before starting the unit it is necessary to carry out the following checks:

- if the unit is charged with R454B, refrigerant, aerate all closed vanes before doing any action;
- check that all the taps in the cooling circuit are open (liquid line) and that the flow switch is closed, by entering the status menu of the digital inputs;
- remove the protective cap of the A2L sensor;
- check that electrical wiring has been carried out correctly and that all the terminals are tightened hard (see paragraph 6.3 Electrical connections p. 28);
- after checking that the unit is powered, check that voltage at the terminals complies with the value indicated on the silver label and the corresponding tolerance; then check that the yellow phase sequence relay light (if any) is lit. The phase sequence relay is marked RSF and failure to observe the sequence will not enable a machine start;
- make sure that there are no refrigerant leaks due to accidental impacts during transport and/or installation;
- check the correct power supply to the enclosure resistors if present.
- check all air has been vented through the vents on the pumps.

WARNING

The introduction of compressor casing resistances, if any, must be done at least 12 hours before the first start-up; it then occurs automatically when the main disconnect switch is closed. They are intended to increase the temperature of the oil in the sump, thus limiting the amount of refrigerant dissolved in it and ensuring that the desired lubrication characteristics are preserved.

- To ensure the correct operation of the heating elements, check that the lower part of the compressors is hot and in any case, that it is at a temperature 10-15°C higher than ambient temperature.

A slight foaming [1-5 mm] of the oil at start-up (pressure drop => decrease in solubility %) is physiological and will not affect the reliability of the system.

- Check that the hydraulic connections have been performed correctly, in accordance with the indications on the data plates on-board the machine (correct inlet and outlet connectors). Please refer to paragraph 6.1 Hydraulic connections p. 25.
- Check that the hydraulic system has been vented, bleeding any residual air, filling it gradually and opening the

venting devices at the top - which the installer must have prepared in advance.

- Check that all the conditions specified in this manual have been observed, among which the working limits and the characteristics of the heat transfer fluid, as will be explained further on.

8.2 Operating limits

The following tables and graphs describe the continuous operation limits of the units.

WARNING

Non-compliance of these limits makes it null and void the stipulated warranty contract.

WARNING

Depending on the working conditions of the unit, it may be mandatory to adopt some devices supplied as options. Please refer to the indications given in the key to the operating limits diagrams.

WARNING

The envelopes shown in the following diagrams refer to the general standard range. The choice of different available options can lead to changes in the corresponding envelope. Please refer to the specific technical selection.

ATTENTION

Standard units with pure water are not designed to operate with chilled water temperatures below 5°C at the plate heat exchanger output. Water can be produced at temperatures below 5°C and down to -10°C using glycolate solutions that lower the freezing point, as shown in paragraph 8.3 Thermal carrying fluid p. 34.

In this occurrence, it is necessary to contact the manufacturer's design department to set up the unit appropriately.

The main limits regarding the operation of the units ELA are:

- Heat transfer fluid: only water or glycol + water mixture with no more than 40% anti-freezing agent
- Water operating pressure: refer to the silver label on the unit
- Input voltage: $\pm 5\%$ of the rated voltage
- Maximum storage temperature: refer to the silver label on the unit and the accompanying declaration of conformity
- Minimum storage temperature: refer to the silver label on the unit and the accompanying declaration of conformity

WATER FLOW AT EVAPORATOR

The rated flow rate is linked to the temperature difference of 5°C between the water inlet and outlet, in relation to the cooling capacity supplied at rated water (12/7°C) and air (35°C) temperatures. Always refer to the technical selection conditions of the unit.

The maximum permitted flow rate is that featuring a temperature difference of 3°C: higher flow rates, while being admissible, will cause unnecessarily high pressure drops. The minimum admissible flow rate features a temperature difference of 8°C or a minimum pressure drop equal to 10 kPa: lower flow rates will cause a reduction in the heat exchange coefficients and too low evaporation temperatures, with the resulting possible activation of the safety devices and unit shutdown.

ATTENTION

It is mandatory to install a mechanical filter (to be provided by the customer or available as an option with the unit supply) at the inlet to the hydraulic circuit of the heat exchangers, under penalty of immediate loss of the guarantee validity.

ATTENTION

Units are designed to operate with water and air temperatures fixed by operating limits. Operation beyond these limits may cause irreparable damage to the units.

ATTENTION

The units are designed to operate in a closed hydraulic circuit. In the case of open tanks, it is advisable to contact the design department which will indicate the best solution to adopt, such as uncoupling the exchanger.

ELA P Operative limits graph

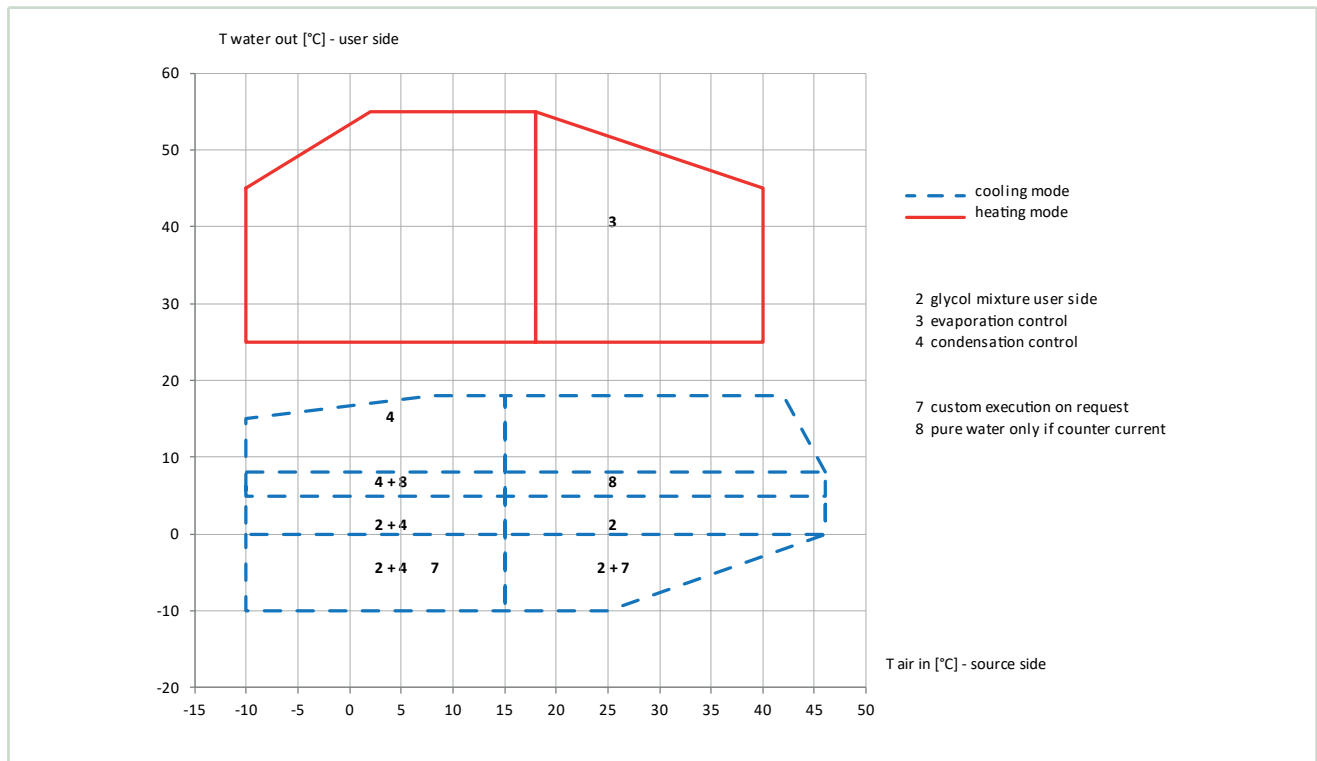

ELA M Operative limits graph (recovery mode)

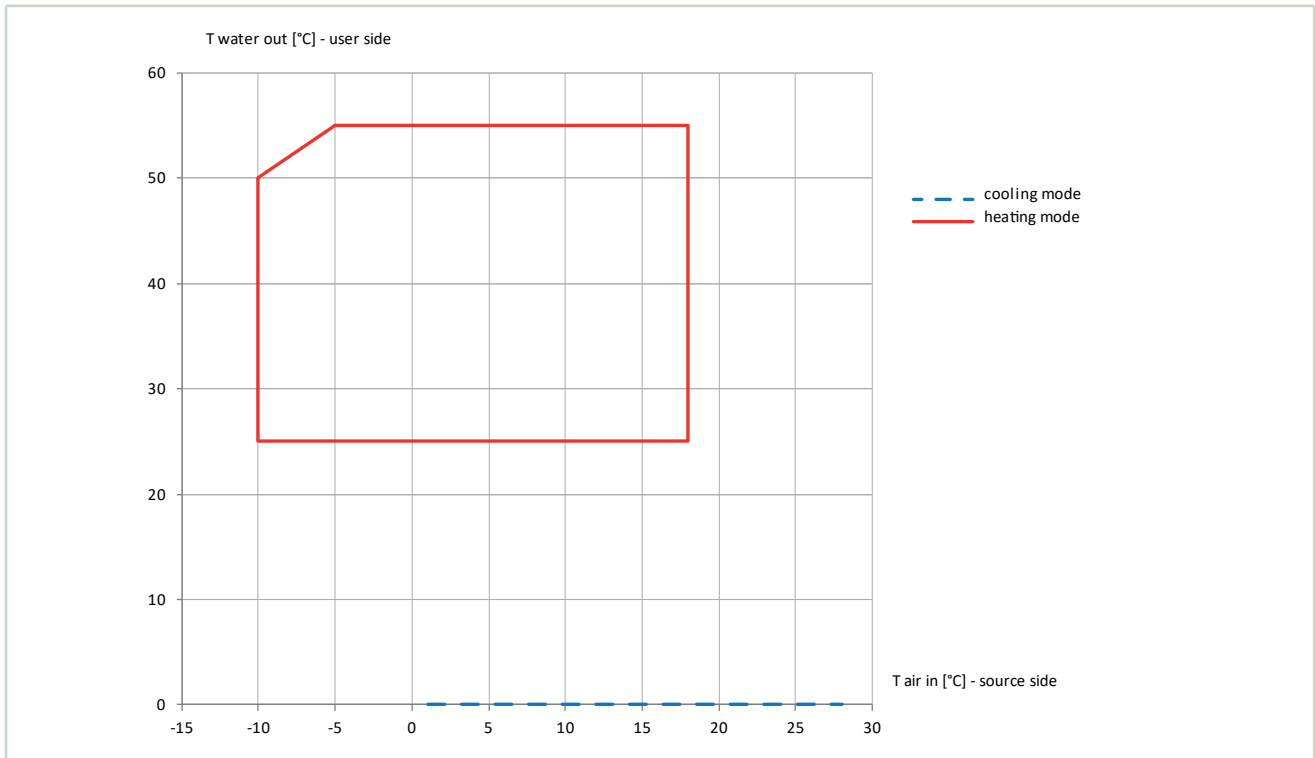

ELA M Operative limits graph

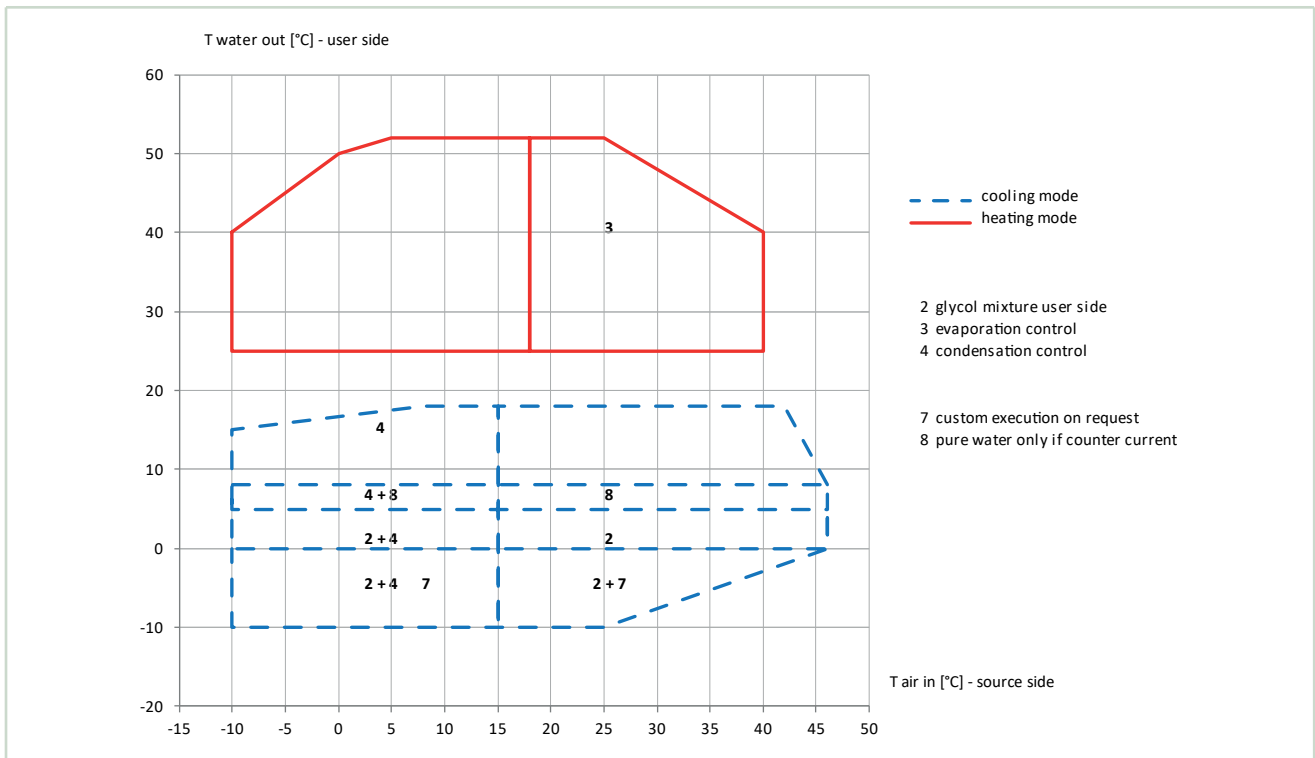

8.3 Thermal carrying fluid

The units of the series ELA can work with mixtures of water and glycol, with percentages of the latter up to 40%.

% by weight of glycol	Freezing temperature of the mixture with ethylene glycol (°C)	Freezing temperature of the mixture with propylene glycol (°C)
0	0	0
10	-3	-3
15	-5	-5
20	-8	-7
25	-11	-10
30	-14	-13
40	-22	-21
50	-34	-33
60	-48	-51

Minimum water production temperature	°C	5	2	1	-3	-6
Glycol percentage by weight	%	0%	10%	15%	25%	30%

The use of glycol will determine a change in terms of heating capacity, water flow and pressure drop. The corrective

Glycol percentage by weight	%	0%	10%	20%	30%	40%
ETHYLENE-BASED	Developed heat capacity correction factor	1,00	1,00	0,99	0,99	0,98
	Water flow rate correction factor	1,00	1,05	1,09	1,14	1,20
	Pressure drop correction factor	1,00	1,16	1,35	1,58	1,86
PROPYLENE-BASED	Developed heat capacity correction factor	1,00	1,00	0,98	0,97	0,96
	Water flow rate correction factor	1,00	1,02	1,04	1,07	1,10
	Pressure drop correction factor	1,00	1,11	1,31	1,53	1,78

8.4 Start-up

Before starting up, If the unit is charged with R454B refrigerant, aerate all closed vanes.

Close the main disconnecter switch, select the desired operating mode on the control panel and press the "ON" key on the control panel (refer to the "First start up instruction", supplied with the documentation).

The group will start if an enabling signal is received:

- from the safety devices related to the water circulation pumps;
- from the flow switch;
- from the water temperature sensor returning from the system [chiller inlet];
- and if there are no alarms present.

In case of starting:

- move the main switch to the ON position;
- if the unit is provided with R454B refrigerant charge, the refrigerant sensors start the activation and measurement procedures.

•The device is designed so as to generally run through all internal device tests (diagnostics) in the sensor control board and the connected gas sensors after each power-up or processor reset before the measuring operation starts. That means that the processor's internal components and the

ATTENTION

If the required amount of 40% glycol needs to be exceeded, or in any case, in conditions of use other than those prescribed by the following tables, please contact the design department for the required checks; doing otherwise will render the equipment warranty null and void.

ATTENTION

Using glycol is necessary in all cases in which the temperature of the heat transfer fluid drops below 5°C, i.e. even when the unit is switched off or only running in summer mode, should this temperature condition occur. This will prevent water freezing and the resulting internal damage to components.

The percentage of glycol must be selected according to the lowest expected temperature. In the following tables, the freezing temperatures of the mixture are given as a function of the glycol content and the recommended amount of glycol - respectively.

factors to be used according to the percentage of glycol are shown in the following table.

associated program and working memories as well as the other components of the input and output units are tested. This process takes approximately 0.5 seconds.

•When all diagnostics have been successful, the connected sensors start their warm-up phase. The warm-up is necessary for the connected gas sensors to assume a stable state after return of the voltage without triggering a pseudo alarm. The warm-up time is approximately 5 min.

- after these checks, the controller will start;
 - the pump will start than immediately;
 - after 60 seconds the compressor starts;
 - check the temperature difference at water level (12-7°C to be checked with a thermometer on the unit inlet and outlet pipes);
 - check that there are no leaks on the refrigerant side and water side;
 - seal the unit with all the screws and panelling supplied.
- If the unit does not start, check that the set point or the thermostat are set to the desired values.

WARNING

The commissioning of the unit must comply with the statutory regulations of the State where the machine is installed. The responsibility for correct use is exclusively ascribable to the user.

To ensure a correct shutdown of the unit, please refer to the paragraph 8.7 Group stop p. 35.

8.5 Inspections during operation

- Check the correct phase sequence by means of the phase sequence relay (a) provided in the electrical control panel: if it is not correct, switch off voltage and reverse two phase wires at unit inlet. Never alter the internal electrical wiring, otherwise the warranty will be voided.

WARNING

All three-phase on-board devices: compressor, water pump, fans (in some versions), have a mandatory rotation direction and have been factory-synched with each other.

- Check that the temperature of the water at the user exchanger inlet (return flow from the system) is close to the set value. The time required to reach steady state conditions depends on the starting conditions, the system size and the load conditions.

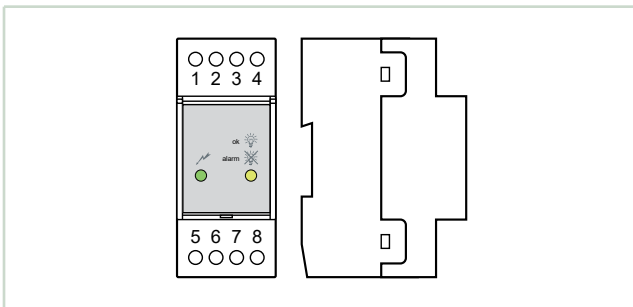

8.6 Refrigerant charge checks

After a few hours of operation, check that the liquid indicator (a) has a green crown: a yellow colour indicates the presence of moisture in the circuit. In this case, the circuit must be drained by qualified personnel.

Check that no large amounts of bubbles appear in the liquid viewing window. A continuous and intense flow of bubbles may indicate low levels of refrigerant which may need topping up. In any case, the presence of some bubbles is allowed, especially if a high glide ternary mixture is used as refrigerant.

After a few minutes from compressors start-up, check (during operation as a chiller) that the end-of-condensation temperature shown on the pressure gauge (refer to the scale of the refrigerant pressure gauge in use and marked with the initials D.P. - Dew Point) is about 16 - 22°C (depending on the type of unit and load conditions) above the temperature of the condenser inlet air with the fans forced to maximum speed.

Also check (during operation as a chiller) that the end-of-evaporation temperature shown on the pressure gauge (refer to the scale of the refrigerant pressure gauge in use, marked with the initials D.P. - Dew Point) is about 3.5 - 4°C lower than the water outlet temperature from the evaporator.

1. Make sure the overheating of the cooling fluid is limited to between 5 and 8 °C. To this end:
 - detect the temperature indicated by a contact thermometer placed on the compressor intake pipe;
 - detect the temperature indicated on the scale of a pressure gauge also connected at the intake end; refer to the scale of the pressure gauge for the refrigerant in use - marked with the initials D.P. (Dew Point).

The difference between the temperatures determined in this way indicates the overheating value.

1. Ensure that undercooling of the refrigerating fluid is between 4 and 6°C; to do this:
 - detect the temperature indicated by a contact thermometer placed on the compressor outlet pipe;
 - detect the temperature indicated on the scale of a pressure gauge connected to liquid intake at the condenser outlet; refer to the scale of the pressure gauge for the refrigerant in use - marked with the initials B.P. (Bubble Point).

The difference between the temperatures determined in this way indicates the undercooling value.

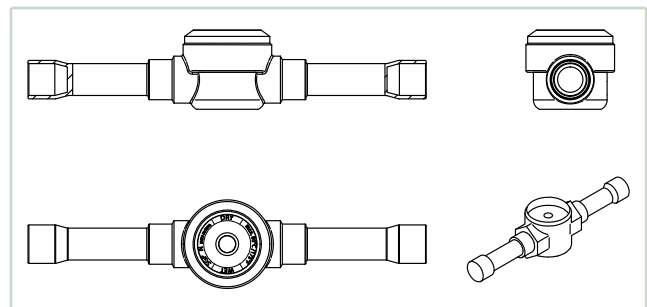

The difference between the Dew Point and Bubble point temperatures is known as “GLIDE” (gliding) and it is typical of refrigerant mixtures. If pure fluids are used, the phase change takes place at a constant temperature and therefore, the Glide is equal to zero. If HFC R410A is used (50%-50% mix of R32/R125) the Glide is negligible (0.2°C) and in actual fact, the fluid is similar to a pure fluid.

ATTENTION

Any charge top-ups must be carried out with refrigerant of the same type as that indicated on the plate, by specialised personnel and exclusively in the liquid phase.

ATTENTION

The R410A / R454B refrigerant requires “POE” polyolester oil of a type approved by the compressor manufacturer. For no reason should mineral oil be introduced in the circuit.

8.7 Group stop

The group is stopped by pressing the “OFF” key on the front panel or by acting on the main disconnecter, or by acting on the special controls of the LCD user interface.

ATTENTION

It is recommended not to power off the unit via the mains power switch during regular shutdowns, but only in case of

expected prolonged idle times (e.g. seasonal stops). The mains switch must be used to cut the unit off from the power supply when there is no current flow, i.e. when the unit is in the OFF state.

Additionally, by completely disconnecting voltage to the unit:

- any casing resistances would not be powered - which would damage the compressor upon its next start
- the only antifreeze protection would be the presence of glycol. If the unit is powered, the antifreeze protection is linked to the presence of the antifreeze option (if present).

 **ATTENTION**

With the machine turned off but powered, the pumps could start automatically. Do not turn off any shut-off valves on the lines and do not carry out work on the lines before having disconnected all power supply to the machine.

When starting the machines (with a compressor) after a prolonged idle time without power supply, allow for at least 4-8 hours for heating of the enclosure via the provided heaters.

9 CONTROL AND SAFETY DEVICES

All control equipment is calibrated and tested at the factory before shipping the machine. However, after the unit has been operating for a reasonable period of time, it is advisable to check the operating and safety devices.

DANGER

All service operations on the control equipment must be carried out **EXCLUSIVELY BY QUALIFIED PERSONNEL**: incorrect calibration values can cause serious personal injuries and damage the unit.

Many of the operating and calibration parameters of control systems are set by microprocessor control and are password protected.

9.1 Control devices

9.1.1 Service thermostat

The service thermostat activates and deactivates the operation of the compressor, depending on chilled water (operation as a chiller) or heated water (operation as a heat pump) requirements, via a probe located at the inlet or outlet of the water exchanger. This device is managed by the microprocessor control and operates with a proportional band of adjustable width. For further details please refer to the control manual.

9.1.2 Control device settings

The calibration values of the control devices set by default for the specific unit are contained in the document "Parameter List", made available to customers by the manufacturer.

9.2 Safety devices

On each refrigerant circuit, according to the volumetric capacity of the installed compressors, the PED (Pressure Equipment Directive 2014/68/EU) category of the machine and the refrigerant circuit configuration, there are safety devices for the refrigeration circuit as prescribed by the PED regulation. In particular, this regulation requires designing to be carried out by referring to the technical standard that is closest to the type of item produced; in the case of machines designed for air conditioning or cooling of liquids, the UNI EN 378-2 standard is referred to.

According to this standard, on a case by case basis, on the high and low pressure sides of each refrigerant circuit safety venting valves can be provided, connected to an exchange tap, to protect the pressurised parts and programmed to be activated when the maximum pressure setting is reached on the corresponding side (PS).

The high and low pressure sides have a maximum pressure PS defined by the pressure limit of the machine components; this pressure cannot be reached during normal machine operation. For more details, refer to the refrigerant circuit diagram of the unit.

During normal use, high pressure at the compressor outlet is limited by the high pressure switch, set to the maximum working pressure of the compressor itself, which depends on the unit model and is equal to the PS, in compliance with the UNI standard EN 378-2.

All the safety devices installed on the units are listed and described here below.

9.2.1 High pressure switch

The maximum pressure switch stops the compressor when its outlet pressure exceeds the preset value.

To check its operation, shut the air flow in the condensers with the compressors running, and check on the compressor delivery pressure gauge (previously installed) that the pressure switch (compressor stop) is activated when the calibration value is reached.

ATTENTION

Any shutdown or alarm must be reported immediately to the service department.

ATTENTION

Do not attempt to change the setting of the maximum pressure switch. Should the latter fail to trip in the event of a pressure increase, the pressure relief valve will open.

ATTENTION

If, during this operation, the safety device is not activated, the second pressure switch in a cascade configuration or a second protection system will operate by switching off the unit; in any case, however, always be sure to be ready to turn the unit off as indicated in section 8.7 Group stop p. 35. See also the paragraph 6.2 Tank filling mode p. 28.

Resetting the high pressure switch must be done manually and only when the pressure has fallen below the value indicated by the set differential value (see 9.2.8 Safety device settings p. 39).

DANGER

The high pressure switch connector does not have the refrigerant sealing needle. Do not unscrew the device: this would cause the refrigerant to flow out of the refrigerating circuit.

9.2.2 Low pressure protections

To ensure protection against low pressure, the units are equipped with a low pressure switch that stops the compressor when the suction pressure falls below the calibration value for a set time.

Resetting is controlled manually and must be carried out by the user via the display.

As an antifreeze protection, a pressure probe is also provided which stops the unit as soon as the pressure falls below the calibration value for a set time.

For more information related to the operation, the calibration values and the set delays, please refer to the microprocessor

manual and the document "Parameter List", supplied with the unit.

9.2.3 Compressors timing

The compressor switching on and off timing schedules programmed by the manufacturer on the units guarantee correct operation of the compressors and an increased durability and stability of the system. They establish:

- the minimum activation time of a compressor, which must remain on for a time equal to the set time;
- the minimum shutdown time of a compressor, which is not powered back on unless the minimum selected time has not elapsed since the last power-off;
- the delay time between two power-on requests of different compressors, i.e. the minimum time that must elapse between two power-ons of the devices independently of the detected measurement and the setpoint;
- the delay time between two successive power-ons of the same compressor, the minimum time that must elapse between two power-ons of the device.

The purpose of the minimum time intervals is to stabilize the operation of the compressors, ensuring adequate circulation of the oil in the refrigerant circuit and preventing too frequent compressor stops and starts, limiting the maximum number of starts per hour.

For more information related to the operation, the calibration values and the set delays, please refer to the microprocessor manual and the document "Parameter List", supplied with the unit.

⚠ ATTENTION

Never change the factory preset time interval: values other than the default ones may cause serious damage to the unit.

9.2.4 Antifreeze thermostat

The antifreeze sensor, located at the outlet of the plate heat exchanger, detects any temperatures that are too low and stops the unit operation.

This function, together with the flow switch, the low pressure switch and the low pressure probe, protects the exchanger against the risk of freezing due to faults in the hydraulic circuit. This device is a feature included in the microprocessor control, for further details refer to the control manual.

⚠ ATTENTION

In the presence of alarms related to the activation of the described protections, the user must request technical assistance, otherwise the guarantee will lapse.

9.2.5 Expansion valve

On all units ELA the electronically controlled expansion valve (a) is fitted as part of the standard equipment. This device, if correctly parameterized and controlled by the software, can make the operation of the refrigeration circuit highly effective, which has as a final effect that of decreasing the power absorbed by the system.

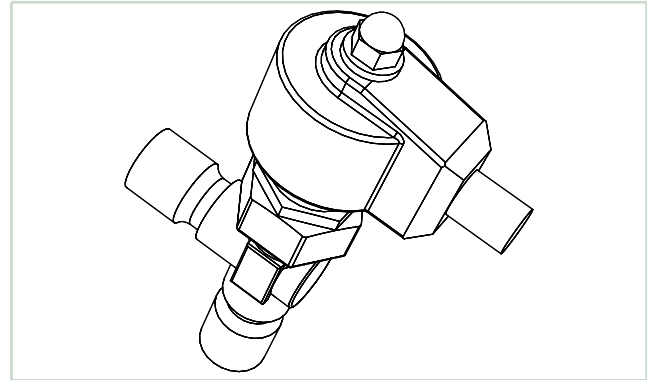

When a sudden change in the thermal load occurs, a traditional expansion valve is designed to be in a transient state for 2-3 minutes before reaching its equilibrium condition. E.g.:

- One compressor switches off
- Evaporation temperature increases
- Overheating decreases
- Valve closes
- Refrigerant flow decreases
- Refrigerating power decreases
- Evaporation temperature decreases
- ... and so on...

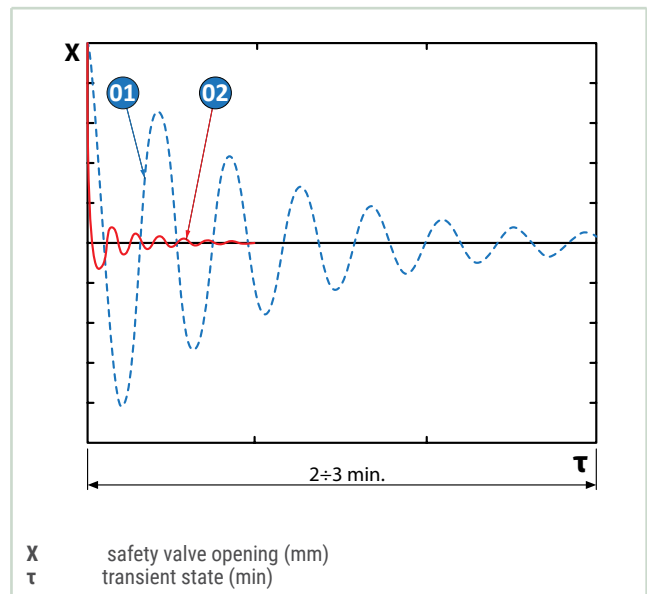

If, on the other hand, there is an electronic expansion valve, in case of a compressor switch on or off request:

- the electronic driver pre-positions the valve at a point very close to that of final balance
- the state of balance is quickly reached by small adjustments
- the expansion valve becomes an active and no longer passive system component
- the transient state lasts for a very short time
- globally, the system is more efficient, with higher EER values and therefore, with more considerable savings.

9.2.6 Water differential pressure switch

The paddle flow switch, supplied pre-mounted and wired or separately as part of the equipment, according to the

different models, stops the unit in case of excessive reduction of the water flow, preserving it from frosting (operation as a chiller) and excessive condensation temperatures (operation as a heat pump).

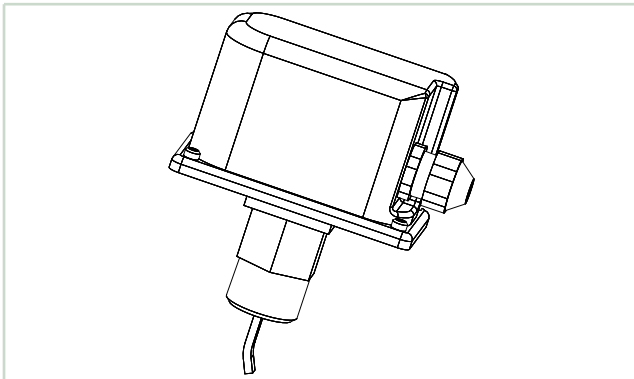

9.2.7 Water safety valve

The water safety valve opens when the pressure within the water circuit reaches a level that may cause damage to the unit.

9.2.8 Safety device settings

The calibration values of the software and mechanical safety devices are visible respectively:

- in the “Parameter List” document, made available to customers by the manufacturer;
- in the silver label provided on the unit.

9.2.9 Refrigerant sensors (if “A2L-ready” and “R454B” refrigerant options present)

When the unit is provided with A2L-ready or R454B refrigerant options, refrigerant sensors are installed in all compressor boxes and in all separated sections of the electrical box.

The refrigerant sensor is composed by:

- A main and a remote control board
- One sensor cartridge for each control board (only for “R454B” refrigerant option)

Pay attention that in the “A2L-ready” configuration the refrigerant sensor cartridge is not present. For this reason, the unit can’t be operated with R454B refrigerant charge. If needed to charge the unit with R454B refrigerant, please see chapter 11 Substitution of R410A with R454B refrigerant p. 46.

For the units provided with R454B refrigerant, the unit is equipped with sensor cartridges.

In addition to the gas sensor element and the measuring amplifier, the sensor cartridge also contains a processor for measured value processing. All data and measured values of the sensor element are stored in the processor fail-safe and are transmitted digitally via the digital interface to the control board.

The control board functions are communication and supply of the gas sensors.

In normal operating mode (measuring mode) there are no faults present, the gas concentration of the active sensors is continuously polled and checked for plausibility.

The device continuously monitors itself, the measurement signal, the alarm relay and the communication to the sensor head.

When the alarm evaluation is activated, the gas signal is checked with each measurement cycle, if \geq or \leq alarm threshold and if exceeding, the alarm LED and the alarm relay are triggered. If the value falls again below the alarm threshold minus the set hysteresis, the alarm is automatically cancelled.

» Refrigerant sensor A2L

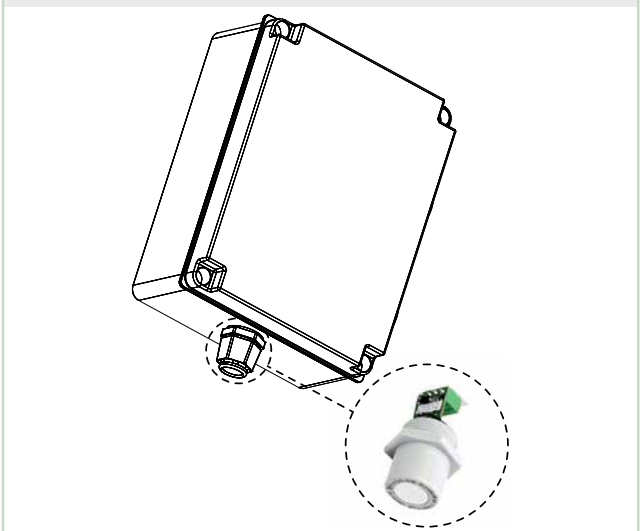

10 ROUTINE MAINTENANCE AND CHECKS

To keep the unit in good working order and guarantee the expected levels of performance and safety, it is necessary to carry out some periodic routine checks: some may be performed directly by the user while others must be carried out solely by specialised personnel.

In any case, the regulations in force in the country of installation must always be complied with.

10.1 Checks to be performed by the user

Operating these machine basically requires just switching on, switching off and seasonal switching between cooling and heating operation.

All other operations are maintenance tasks and must be performed by qualified personnel who are able to operate according to the laws and regulations in force.

ATTENTION

Pay special attention when working near the finned exchangers as the aluminium fins are very sharp.

10.2 Checks and maintenance to be performed by specialised personnel

The periodic inspections that must be performed by qualified and authorised personnel are indicated in the following chapter.

DANGER

- All the operations described in this section **MUST ALWAYS BE PERFORMED BY QUALIFIED PERSONNEL**.
- For safety reasons, adequate measures and precautions must be taken regarding installation, to prevent ambient temperature - when the machine is switched on or off

- exceeding the provisions of paragraph 8.2 Operating limits p. 31.
 - Before performing any work on the unit or accessing internal parts, be sure to have disconnected power supply.
 - The compressor delivery pipe and upper part reach a maximum temperature of 110°C. Be very careful when operating nearby with the unit in operation.
 - Pay special attention when working near the finned exchangers as the 0.11 mm thick aluminium fins can cause superficial cuts.
 - After maintenance operations, always close back the unit using the provided panels, fixing them with their tightening screws.
 - For the safety of the maintenance staff in charge of the groups ELA, it is essential to switch off the unit from the main switch before carrying out maintenance operations.
- To preserve the unit from possible faults and guarantee its correct operation over time, it is necessary to regularly carry out the inspections shown in the following table.

WARNING

The following table is for general guidance: please do not consider any operations involving components not present in a specific model.

This table shows the inspection schedule recommended by the manufacturer to ensure the expected performance and safety levels. For information on the inspection schedule and methods required at regulatory level, especially for the prevention of refrigerant leaks, the main European reference standards are EN-378 and the European F-Gas Regulation No. 517/2014. If there is a national regulation, reference should be made to it.

All the following procedures must be performed in compliance with the safety regulations described in this manual.

WARNING

In case of extraordinary maintenance (e.g. replacement of components) contact the technical department for the correct tightening torques. If the compressor is replaced, the filter must also be replaced.

ACTION		MAINTENANCE FREQUENCY			
		1 month	3 months	6 months	1 year
UNIT	Check that no unusual noise is emitted by the machine and in particular, that there are no vibrations and/or beating.			x	
FANS Caution: do not access the fan while the fan wheel is in operation	Check for dirt, damage, corrosion, wear and ensure correct fixing.	x			
	Check for any noise of the bearings and the balancing of the shaft.	x			
	Measure current and power consumption.			x	
	Check the electrical connections.		x		
	Clean to preserve smooth functioning.		x		
	Check the correct closing of the electrical box (if available).			x	
AIR FILTERS	Check for dirt, damage, corrosion, and wear.	x			
	Check the filter condition.	x			
	Clean or replace if necessary.	x			
	Perform checks more frequently in dusty environments.	x			
	Check the efficiency of the differential pressure switch for dirty filters.			x	

ACTION		MAINTENANCE FREQUENCY			
		1 month	3 months	6 months	1 year
CONTROL SYSTEM	Check the correct installation and the wiring conditions.	x			
	Check the operation of the LEDs of the display control system and of the alarms.		x		
	Check the connections for electrical and mechanical operation.			x	
	Check the functional elements (e.g. operating controls and display devices).			x	
	Check electrical/electronic and pneumatic input signals (e.g. sensors, remote controllers, control variables) to conform to normal values.			x	
	Check the values in the parameter list (see the Microprocessor Manual).				x
	Adjust the control function and control signals. Check the software cycle running (see the Microprocessor Manual).			x	
SWITCH BOOTH POWER SUPPLY CIRCUITS Caution: the electric cables and electrical components of the air conditioner are live.	Check the power supply in all phases.			x	
	Check the electrical connections and the mechanical function. Restore if not properly tightened.			x	
	Check the power supply of all the terminals.			x	
	Measure power consumption at all connected devices.			x	
	Check, adjust and tighten the functional elements (e.g. operating controls and display devices).			x	
	Check the safety equipment, e.g. thermal switch. Replace every 2 years.				x
	Check the protective covers.				x
CONDENSATE/FREECOOLING COOLING WATER	Check the tightening of the electrical terminals both inside the electrical panel and in the compressor terminal blocks. The mobile and fixed contacts of the contactors must be periodically cleaned and, if they show signs of deterioration, they must be replaced.				x
	Check the cooling water circuit, check for damage, leaks and ensure correct fixing.	x			
CONDENSATE/FREECOOLING COOLING WATER PUMP	Check the correct flow of water and clean the water filter.		x		
	Make sure the water pump works correctly.			x	
	Check the correct flow of water; clean the water filter.		x		
	Check for internal air: bleed air if present from closed circuits.		x		
	Check the safety equipment; water flow switch etc.			x	
	Check the percentage of glycol by comparing the minimum annual ambient temperature.			x	
REFRIGERATION CIRCUIT Fluoride based refrigerants increase the greenhouse effect and are expected to conform to restrictions and regulations, according to national and European standards.	Check the pumps for excessive noise.				x
	Measure the pressures and working temperatures (to be performed by a refrigeration technician).			x	
	Check the energy consumption, measure the heat temperature and check for unusual noise during operation.			x	
	Make sure there is no frost formation in the evaporator and in the compressor.		x		
	Check the operation of all the adjustment devices (power regulators, valves, etc.).	x			
	Check the efficiency of the actuators.				x
	Check the operation of the safety devices.			x	
	Check the refrigerant charge, the liquid level indicator and the operating parameters (undercooling, overheating, high and low pressure, degree of valve opening). If the amount of refrigerant is not sufficient, it must be restored by refilling with fresh refrigerant.			x	
	Check the oil level through the appropriate viewing windows.		x		
	Perform a test to check the oil internal humidity level.				x
	Check the enclosure heater operation.			x	
FINNED PACK EXCHANGERS	Check the humidity indicator on the liquid indicator (green = dry, yellow = wet); if the indicator is not green, as shown by the indicator sticker, replace the filter.			x	
	In the case of internal heat exchangers, clean the finned pack with compressed air or brushes. If the unit is located in particularly dusty environments, perform the inspections more frequently.			x	

ACTION		MAINTENANCE FREQUENCY			
		1 month	3 months	6 months	1 year
CHILLED WATER CIRCUIT	Check the filling of the hydraulic circuit, by venting it from the valves placed at the highest points.			x	
	Make sure that there are no water leaks.			x	
	Check for any air in the circuit: bleed air from the cooling water circuit using the special valve in the top part of the circuit.			x	
	Check that chilled water supply is guaranteed.			x	
	Check the water temperature and pressure at the inlet and outlet using thermometers and pressure gauges - if installed.			x	
	Check the correct operation of the 2- or 3-way valve.			x	
	Check the efficiency of the actuators.				x
	Make sure that the system is filled with the prescribed amount of glycol and that there is no ice in the hydraulic circuit.			x	
	In the event that there is a water leak and the circuit must be filled, make sure that the glycol concentration is correct.			x	
	Check that the water circulation is as required.			x	
	If the unit is expected not to be in operation for a long time, drain the water from the pipes and the machine, including the water exchanger if it is a Free-Cooling unit (if no glycol-based solutions are used). This operation is mandatory if ambient temperatures are expected to fall below the freezing point of the fluid used, during the unit down time.				
	Clean the external metal filters in the hydraulic lines.			x	
	Check the efficient operation of the flow switch or differential pressure switch.			x	
REFRIGERANT SENSORS (only if "A2L-ready" and "R454B" refrigerant options selected)	Check for maintenance.		x		
	Visual inspection of the device including cable for damage, vandalism etc.		x		
	Remove dust deposits etc. with a dry cloth, especially at the gas inlet.		x		
	Clean of the gas inlet filter.		x		
	Sensor cartridge replacement.				x

WARNING

Above a specific refrigerant charge, the installer is requested to prepare a system booklet which must be written and updated regularly for each maintenance operation, according to instructions provided by the applicable standards, including EN 378-2 and the European Regulation F-Gas n. 517/2014. In any case, the plant manager must comply with the regulations in force in the country of installation.

10.2.1 Inspection of the unit during service

EN 378-4: 2016 provides a number of indications concerning the checks to be performed on the unit during its working life.

WARNING

The information regarding in-service inspection contained in the aforementioned standard can be used if there are no similar criteria in the applicable national legislation.

This information is summarised in the standard in a table shown here below.

» In-service inspection

Subclause	Inspection		Test		
	External visual inspection according to Appendix G of EN 378-2:2016	Corrosion	System pressure test	Refrigerant leak detection system ^a	Safety devices inspection
D.2	✓		✓	✓	
D.3	✓		✓	✓	
D.4	✓			✓	
D.5				✓	
D.6					✓
D.7	✓			✓	
D.9		✓ ^b			

^a The system pressure must be higher than the atmospheric pressure for the leak test.
^b Not for new equipment.

— D.2 In-service inspection is performed after a maintenance service that could affect the resistance, or when a change in use has occurred, or when switching to a

different refrigerant at higher pressure, or after the equipment has been idle for more than two years. Components that are not compliant are changed. No test pressures

higher than those suitable for the components' PS are applied.

- D.3 An in-service inspection is carried out after repairing or introducing significant changes or expansions in systems or components. Tests should be limited to the parts concerned.
- D.4 An in-service inspection is performed after reinstallation on another site.
- D.5 The system leak test must be performed if leaks are strongly suspected. For the purposes of this paragraph, "inspected for leaking" means that the equipment or system is primarily tested for leaks using direct or indirect measurement methods, focusing on those parts of the equipment or system most likely to leak. The leak inspection frequency varies from:
 - every 12 months for systems with at least 3 kg of refrigerant, with the exception of hermetically sealed systems containing less than 6 kg;
 - every 6 months for applications containing at least 30 kg of refrigerant;
 - every 3 months for applications containing at least 300 kg of refrigerant.

Systems must be inspected to check for leaks in the month following the repairing of a leak, to ensure that the repair has been effective.

For applications containing at least 3 kg of refrigerant, the operator must keep track of the amount and type of refrigerant used, the top-up quantities added and the amount recovered during maintenance, service and final disposal. For applications containing at least 300 kg of refrigerant, the operator must install leak detection systems. These systems should be inspected at least once every 12 months to ensure their proper operation.

Where an efficient leak detection system is provided on site, the inspection frequency may be halved.

High leak rates are not acceptable. Actions should be taken to eliminate any detected leak.

ATTENTION

Fixed refrigerant detectors are not leak detectors because they cannot locate leaks.

- D.6 Safety devices are checked on-site: every year for safety switching devices (see EN 378-2: 2016 6.3.4.3.3), emergency signals and alarm systems; every five years for external pressure relief devices.
- D.7 Overpressure relief valves and break discs are visually inspected in accordance with EN 378-2: 2016, 6.3.4.3.1, 6.3.4.3.4 and 6.3.4.3.5 and annually tested for leaks.
- D.8 In the case of systems fully assembled and tested before their installation and systems built at the factory and transported as complete assemblies, or in two or more sections, the in-service inspection is performed after repairs have been carried out. If there are obvious refrigerant leaks, the entire system is leak tested.
- D.9 When pipes, piping supports, components and component supports are not insulated, they must be visually inspected. Pipes and insulated components must be visually inspected if the vapour barrier is damaged or if it does not work as intended.

This information must be supplemented with the provisions defined by the regulations on maintenance, including the European F-Gas Regulation No. 517/2014. In any case, the

regulations in force in the country of installation must always be referred to.

10.2.2 Refrigeration circuit repairs

ATTENTION

Do not stand with sources of heat and open flames during the loading and unloading procedures of the machine.

During any repairs to the refrigeration circuit or compressor maintenance, minimise the opening time of the circuit. Even short exposure times of the ester oil to ambient air will cause the absorption of large amounts of moisture by the oil with the resulting formation of weak acids.

If the refrigeration circuit has been repaired, the following operations must be carried out:

- leak test;
- refrigeration circuit vacuum and drying cycle;
- refrigerant charge

WARNING

If the system needs to be drained, always collect all the refrigerant present in the circuit using suitable equipment, by working exclusively in the liquid phase.

10.2.2.1 Leak test

As far as leak tests are concerned, the units will leave the factory after having been tested according to the procedures indicated in EN 378-2.

A leak test on the installation site is necessary whenever the refrigeration circuit has been repaired or if the cooling connection between modules of a split unit must be carried out.

ATTENTION

Leak tests on site must be carried out by specialised and authorised personnel, who must operate according to the methods indicated in EN 378-2, if applicable in the country of installation, or according to local regulations in force.

10.2.2.2 High vacuum and refrigeration circuit drying

To obtain high vacuum in the refrigerant circuit, it is necessary to have a pump capable of generating a high degree of vacuum, at least 15 Pa of absolute pressure, with a capacity of 10 m³/h. If this pump is available, normally one draining only should be controlled to reach the absolute pressure of 15 Pa.

When a suitable vacuum pump is not available or when the circuit has been open for long periods of time, it is strongly recommended to follow the triple draining method. This method is also indicated when there is moisture in the circuit.

The vacuum pump must be connected to the charging points. The required procedure is as follows:

- Drain the circuit to an at least 35 Pa absolute pressure: at this point, introduce nitrogen in the circuit up to a pressure of about 1 bar.
- Repeat the operation described in the point here above.
- Repeat the operation described in the point here above for the third time, now trying to achieve the hardest possible vacuum condition.

With this procedure it is possible to easily remove up to 99% of the pollutants.

10.2.2.3 Refrigerant charge

DANGER

Before carrying out any operation with the refrigerant, it is recommended to read the special safety data sheet (MSDS). The refrigerants used in the entire Eneren product range are R410A R454B.

These have the following characteristics:

- **TOXICITY**, the refrigerants mentioned above all belong to group A according to the standard 34 ASHRAE; this group includes all refrigerants that are found not toxic for concentrations equal to or lower than 400 ppm.
- **FLAMMABILITY**, according to the standard 34 ASHRAE, refrigerant R410A is classified in the safety group A1, i.e. non-flammable at a pressure of 1 atm (101.3 kPa) and 18°C. R454B is classified in the A2L safety group, i.e. mildly flammable at 1 atm pressure (101.3 kPa) and 18°C.
- **CATEGORY**, the refrigerants used are fluids of category II according to the PED 2014/68/EU directive and therefore, they are not dangerous.

The area must be immediately evacuated if there is a constant leak of refrigerant gas. The gases concentrate near the floor, thereby restricting the availability of oxygen. Once evacuated, the area must be ventilated with fans or blowers in order to circulate the air at floor level.

For loading operations, follow the procedure described below:

- connect the refrigerant gas cylinder to the 1/4 SAE male filler outlet located on the liquid line, making sure that there are no impurities, moisture and/or incondensable gases in the inlet pipes;
- load liquid state charge until 75% of the total charge has been introduced;
- then connect to the intake on the suction line and complete liquid charge loading until no more bubbles appear on the liquid viewer and the operating values are reached that are indicated in the paragraph 8.6 Refrigerant charge checks p. 35.

ATTENTION

A unit originally filled at the factory with a refrigerant type cannot be filled with different refrigerants without a written permission from manufacturer.

If the (mildly flammable) R454B is used, it is recommended to provide all the safety devices required by law during installation. In case of indoor installation, contact the manufacturer.

Refer to paragraph 13.2 Environment protection p. 49 contained in this document.

10.2.3 Refrigerant sensors (only if A2L-ready and R454B refrigerant options selected)

It is obligatory to perform maintenance regularly in order to maintain safety, measuring and warning functions of the device. The maintenance includes visual, functional and system inspections and must only be carried out by appropriately qualified personnel.

When carrying out maintenance and repair work according to the user manual, only use original spare parts from MSR-Electronic. Repairs or changes of the warning devices not complying with the maintenance manual or carried out by unauthorized persons can affect proper equipment and safety features and always result in a termination of the manufacturer's warranty and certificates.

For scheduled maintenance of the sensor by qualified technicians, please contact Technical Support Eneren.

According to EN 45544-4, inspection and service has to be executed at regular intervals. The maximum intervals have to be determined and observed by the person responsible for the gas warning system according to the legal requirements. It is recommended to apply the inspection and maintenance intervals as prescribed in the general regulations of the gas measuring technique like EN50545, VDI-2053, EN 60079-29-1 etc. The inspection interval normally is three months.

During inspection it has to be checked in particular:

- Maintenance / calibration interval not exceeded;
- Visual inspection of the device including cable for damage, vandalism etc;
- Remove dust deposits etc. with a dry cloth, especially at the gas inlet;
- The filter at the gas inlet has to be replaced if extremely dirty.

When the calibration period exceeds, it is recommended to contact Eneren Technical Support to have a new sensor cartridge.

ATTENTION

The refrigerant leak sensor alarm may also be triggered by an open control panel door or a clogged panel fan filter.

10.2.3.1 Change of sensor cartridge SC2 on sensor board MSR WSB2 (only if R454B refrigerant option selected)

Products involved

1. SENSOR BOARD WSB2, Code – HF11000741 SENSORE GAS MSR;
2. SCHEDA BASE WSB2 REMOT CARD Code – HF11000742 SENSORE GAS MSR;
3. SCHEDA REMOTA RB2 SENSOR CARTRIDGE SC2, following Codes for different refrigerants:
 - A. SENSORE GAS MSR, CARTUCCIA R1234ZE – HF11000743;
 - B. SENSORE GAS MSR, CARTUCCIA R410A – HF11000988;
 - C. SENSORE GAS MSR, CARTUCCIA R452B – HF11000951;
 - D. SENSORE GAS MSR, CARTUCCIA R513A – HF11000786;
 - E. SENSORE GAS MSR, CARTUCCIA R454B – HF11000950

General description

ATTENTION

The cartridge must be replaced every 12 months. After 12 months the alarm 231 is generated (displayed on the microcontroller) and the machine is stopped.

To view the total operating hours of the sensor, access the "info" menu of the microcontroller. As the sensor will need to be replaced after 8640 hours, make sure that service by a qualified technician is scheduled in good time.

Exchange of sensor cartridge

The sensor cartridge (SC) can be easily and conveniently replaced with a new one.

The local bus communication (Sensor Cartridge <-> BSB) is constantly monitored during operation and immediately generates an error message on the gas controller in case of failure or interruption. When replacing the sensor unit, local bus communication is also interrupted and this produces an error message.

The local bus communication is automatically established and tested. At the same time the gas type and the measuring range of the "new" SC are compared with the data stored in the BSB. If they match and the communication is correct, the error message will be automatically acknowledged at the Gas Controller.

After replacing the sensor, the counter must be reset from the microcontroller display:

» A2L sensor maintenance display

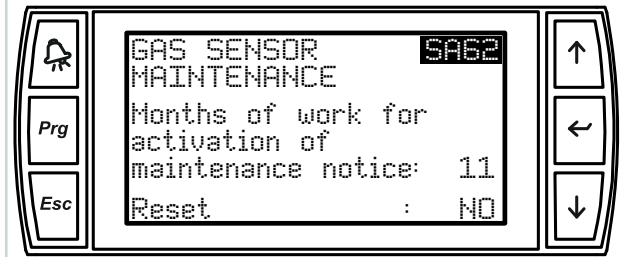

ATTENTION

For others useful information please read supplier manuals

» Exchange of sensor cartridge

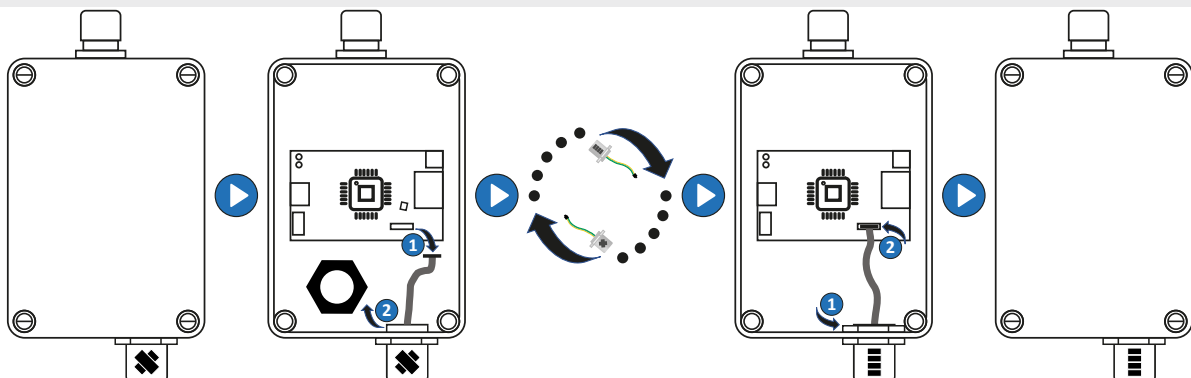

- Disconnect the SC connector from the BSB or the RSB (error message will be activated);
- Loosen the locknut;
- Remove used SC;

- Take calibrated SC out of the original packaging, check for gas type, measuring range and valid calibration date;
- Insert the SC and retighten with lock nut;
- Insert the SC plug into the socket at the BSB or RSB. Check plug for proper engagement.

10.3 Components description

For a clear representation of the components that make up the unit, please refer to the wiring diagram supplied with the unit.

11 SUBSTITUTION OF R410A WITH R454B REFRIGERANT

In the units provided with A2L-ready option, it is possible to substitute the R410A refrigerant with the new generation refrigerant R454B.

All the actions connected to the refrigerant substitution must be performed by authorized technicians, who will:

- certify the correct execution of the charging process;
- check for the correct start-up and operation of the refrigerant sensors;
- provide a new silver label to replace the old one.

Please contact Eneren Support Team to organize the substitution process.

12 TROUBLESHOOTING

For troubleshooting purposes, please refer to the list and to the complete description of the alarms related to the installed software version.

This document can be downloaded from the portal <https://obdoc.gallettigroup.com> after user registration.



WARNING

Do not reset the alarm until after an accurate analysis and subsequent removal of the causes of the alarm: continuous resetting operations could lead to compressor breakdowns.

DANGER

As far as possible remedies are concerned, it is first of all essential to have read the chapter “4 Safety prescriptions p. 11”, to be able to adopt all the necessary precautions.

You should be extremely careful when attempting to implement any of the possible remedies suggested: overconfidence can result in injuries, even serious ones, to inexperienced individuals.

In case of breakdowns, please contact a qualified and authorised technician or our customer care.

» Troubleshooting

Fault	Possible causes	Corrective action
The unit does not start	No electrical power supply.	Check its presence both on the primary and auxiliary circuit.
	The circuit board is not powered.	Check the fuses.
	There are alarms present.	Check the microprocessor panel for the presence of alarms, eliminate their cause and restart the unit.
	The phase sequence is wrong.	Invert two phases in the primary power line after disconnecting them upstream from the unit.
The compressor is noisy	The compressor is rotating in the wrong direction.	Check the phase sequence relay. Invert the phases on the terminal board after disconnecting the unit and contact the manufacturer.
Faulty high pressure	Insufficient flow of air to the condenser.	Check that all fans turn correctly.
		Check the compressor inlet air T and avoid any situations of backflow.
		Check that the effective voltage RMS to the fans is the maximum. Check the pilot pressure transducers of the rev. regulator [optional].
	Make sure the finned coils are clean.	
Presence of air in the refrigerant circuit, as revealed by the presence of bubbles in the flow indicator also with undercooling values exceeding 5°C.	Drain and pressurise the circuit and check for leaks. Evacuate slowly [for more than 3 hours] until reaching a pressure of 15 Pa and then recharge in the liquid phase.	
Unit overcharged. As revealed by an undercooling of more than 8°C.	Drain the circuit.	
Clogged thermostatic valve and /or filter. Such faults may occur in the presence of low pressure.	Check the temperatures upstream and downstream from the valve and filter and replace them if necessary.	
Low condensation pressure	Faulty transducers.	Check the transducers and the correct operating of the depressor on the Schrader valves to which they are connected.
	Too low external T and/or in the presence of strong winds.	Install the condensation control device and/or protect the unit from the prevailing winds.
Low evaporation pressure	Malfunctioning of thermostatic valve.	Warming the bulb with your hand, check whether the valve opens and adjust it if necessary. If it does not respond, replace it.
	Filter clogged.	Pressure drops upstream and downstream from the filter should not exceed 2°C. If they do, replace the filter.
	Low condensing temperatures	Check the efficiency of the condensation control device [where present].
	Low level of refrigerant	Check the refrigerant level by measuring the degree of undercooling; if it is below 2°C replenish the charge.
	Coil frosted if heat pump is operating.	Check the correct defrost parameter settings. Make sure the 4-way valve works properly.
Low external T if heat pump is operating.	Check compliance with the operating limits and eliminate any bypasses and back flow of air.	
The compressor does not start	The thermal protection device has tripped.	Check the status of the thermal contact in models equipped with protection modules. Identify the causes after restarting.
	Tripping of circuit breakers or fuses in line after short circuit.	Check the cause by measuring the resistance of the individual coils and the isolation towards the chassis before re-connecting the power.
	Activation of one of the high or low pressure switches.	Check on the microprocessor, eliminate the causes.
	The phases in the distribution cabin have been inverted.	Check the phase sequence relay.

Defrosting absent or incomplete (H versions)	Error in parameter settings.	Check the setting of the start and end defrost parameters on the microprocessor.
		Check whether defrosting water is properly drained from the coils.
		Check the homogeneous distribution of the refrigerant temperatures throughout the height of the coil: the maximum allowed delta is 10°C. Check the machine charge.
	Poor efficiency of the 4-way valve.	Check that it is energised and de-energised regularly.
Free Cooling malfunction (F versions)	Poor efficiency of the 3-way valve.	It is possible to manually force the valve to open, but it is advisable to leave the unit in mechanical operation only.
	Poor efficiency of the 3-way valve.	È necessario forzare manualmente in chiusura la valvola, sostituendone quanto prima il servomotore.

13 RETIRING THE UNIT

When the unit has reached the end of its expected working life and therefore needs to be removed and replaced, a number of precautions must be followed:

- the refrigerant gas that it contains should be recovered by specialised personnel and sent to a waste collection facility;
- the lubrication oil of the compressors must also be recovered and sent to special collection centres;
- the structure and the various components, if not reusable, must be demolished and separated according to their product type: this is particularly relevant for copper and aluminium, which are present in fairly high amounts in the machine.

This should be done to facilitate work at the special collection, disposal and recycling centres and to minimise the environmental impact that this operation requires.

ATTENTION

If the unit, or part of it, has been decommissioned, any of its parts that are likely to cause dangers must be rendered harmless.

Please note that any replacement of unit parts subject to separate waste disposal must always be done by referring to the currently applicable legal provisions.

Please note that it is mandatory to record the loading and unloading of special and toxic-harmful waste.

Collection of special and toxic-harmful waste must be carried out by specially authorized companies.

Disposal of special and toxic or harmful waste must be carried out in compliance with the law provisions in force in the user's country.

For unit scrapping, follow the law prescriptions in force in the user's country. Before demolition ask the appointed organism to inspect the unit and write a report.

Finally, carry out scrapping according to the law in force in the country of use.

WARNING

Dismantling, disposal and scrapping operations must be carried out by qualified personnel.

13.1 Waste electrical and electronic equipment management

This product falls within the scope of the Directive 2012/19/EU concerning the management of waste electrical and electronic equipment (WEEE). The equipment must not be disposed of with domestic waste as it is made of different materials that can be recycled by delivering them to special facilities. Inquire with the municipal authority regarding the location of the waste management areas where the product can be delivered for disposal and its subsequent correct recycling. Please be also reminded that, when a new equivalent appliance is bought, the dealer is

expected to collect the old product for disposal free of charge. The product is not potentially dangerous for human health and the environment, does not contain harmful substances according to the Directive 2011/65/EU (RoHS), but if disposed of in the environment, it may negatively impact the ecosystem. Read the instructions carefully before using the equipment for the first time. It is strongly recommended not to use the product for any purpose other than that for which it was designed, to prevent the risk of electric shock if the product is used incorrectly.

WARNING

The crossed-out bin symbol, on the equipment label, indicates product compliance with the regulations on waste electrical and electronic equipment. Disposing of the equipment in the environment or illegal disposal of the equipment is punishable by law.

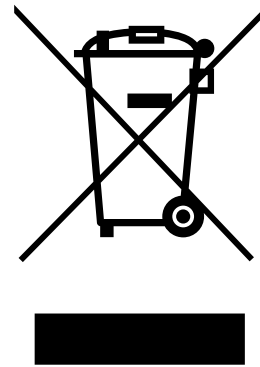

13.2 Environment protection

In general, the laws regulating the use of substances that damage the stratospheric ozone layer and the gases responsible for the greenhouse effect in force in the various countries provide that it is forbidden to disperse refrigerant gases in the environment and request their originators to recover them and return them, at the end of their service life, to the retailers or to special collection centres.

The HFC R410A and R454B refrigerant, although not harmful to the ozone layer, is listed among the substances responsible for the greenhouse effect and must therefore be used in compliance with the above obligations.

ATTENTION

Caution is therefore recommended during maintenance operations in order to minimise refrigerant leaks as much as possible. In any case, refer to the laws in force in the country of installation.

13.3 Packaging disposal

The QR Code below is shown on a label on the packaging of the machine, which allows the user to identify the nature of the packaging used in order to follow the correct disposal procedure.



ATTENTION

For disposal of packaging, always refer to local laws that implement Directives 2018/851/UE and 2018/852/UE.

14 SAFETY DATA SHEET OF REFRIGERANT

For refrigerant fluid safety data sheet, please refer to the documents supplied with the unit.



Viale Spagna, 31/33 - 35020 Tribano (Padova) - Italy
Ph. +39 049 9588511 - Fax: +39 049 9588522 - info@eneren.it
www.eneren.it